



element14

EN - For pricing and availability in your local country please visit one of the below links:

DE - Informationen zu Preisen und Verfügbarkeit in Ihrem Land erhalten Sie über die unten aufgeführten Links:

FR - Pour connaître les tarifs et la disponibilité dans votre pays, cliquez sur l'un des liens suivants:

[8.07.01 SWD ISOLATOR](#)

EN

This Datasheet is presented by
the manufacturer

DE

Dieses Datenblatt wird vom
Hersteller bereitgestellt

FR

Cette fiche technique est
présentée par le fabricant



J-Link SWD Isolator

The J-Link SWD Isolator can be connected between [J-Link](#) and any ARM-board that uses the standard 20-pin 0.1" male connector to provide electrical isolation. This is essential when the development tools are not connected to the same ground as the application. It is also useful to protect the development tools from electrical spikes that often occur in some applications, such as motor control applications. Another typical field of application is development of products with sensors or other analog circuitry, in which case the target hardware is protected from electrical noise originating from the development PC.

The J-Link SWD Isolator is compatible with [J-Link BASE](#), [J-Link PRO](#), [J-Link ULTRA+](#), [J-Link PLUS](#) and [Flasher ARM](#).

Power supply

Both sides, target and emulator, are totally isolated from each other and separately powered. The target side draws power from pins 1 or 2, the emulator side draws power from pin 19. To avoid current drawn from the target an external power supply can be used to provide power to pins 1 and 2.



Features

- 1kV DC isolation
- 3.3V and 5V target operation supported
- Powered from emulator and target
- Standard 20-pin 0.1" male (target side) and female (emulator side) connector supporting SWCLK, SWDIO, SWO, RESET signals
- Power consumption on target side: 25mA typ. / 40mA max.
- SWD frequency: Up to 4MHz
- 3 LEDs to indicate emulator power, target power and target RESET

Pricing

J-Link SWD Isolator can be purchased directly from SEGGER. For more information regarding pricing and part number of the J-Link SWD Isolator, please refer to the [price list](#).

Connectors and indicators

The SWD Isolator uses high speed optocouplers that allow a very low propagation time between input and output. It comes with the following connectors and indicators:

- 20-pin 0.1" female EMULATOR connector which can be plugged directly into J-Link
- 20-pin 0.1" male TARGET connector for connection of the target cable
- Green LED indicating power on the emulator side
- Green LED indicating power on the target side
- Red LED indicating RESET active

Block diagram

The following functional block diagram illustrates the functional connections between the emulator and target.

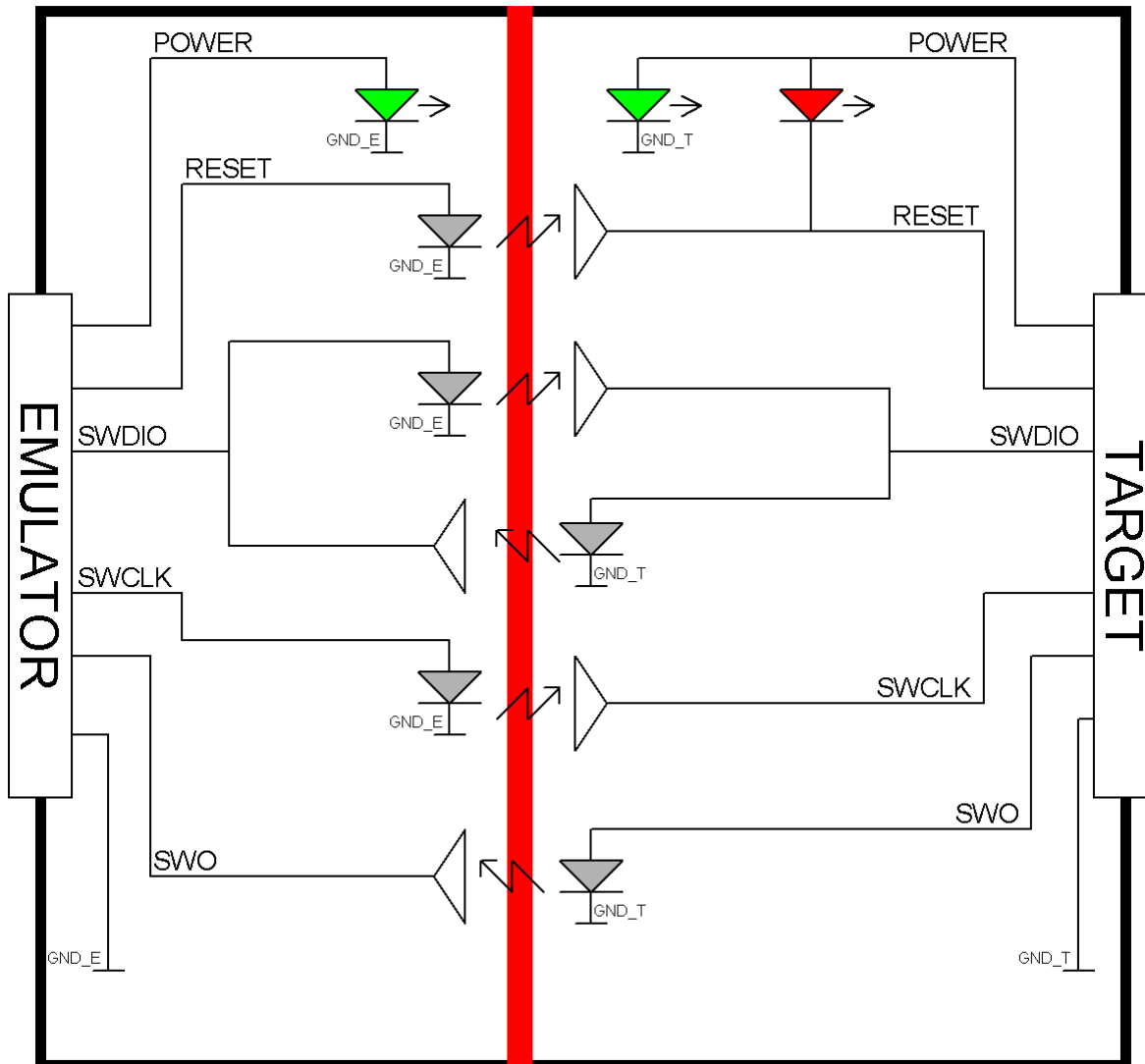

Target connector

The following picture shows the target side pinout of the J-Link SWD Isolator:

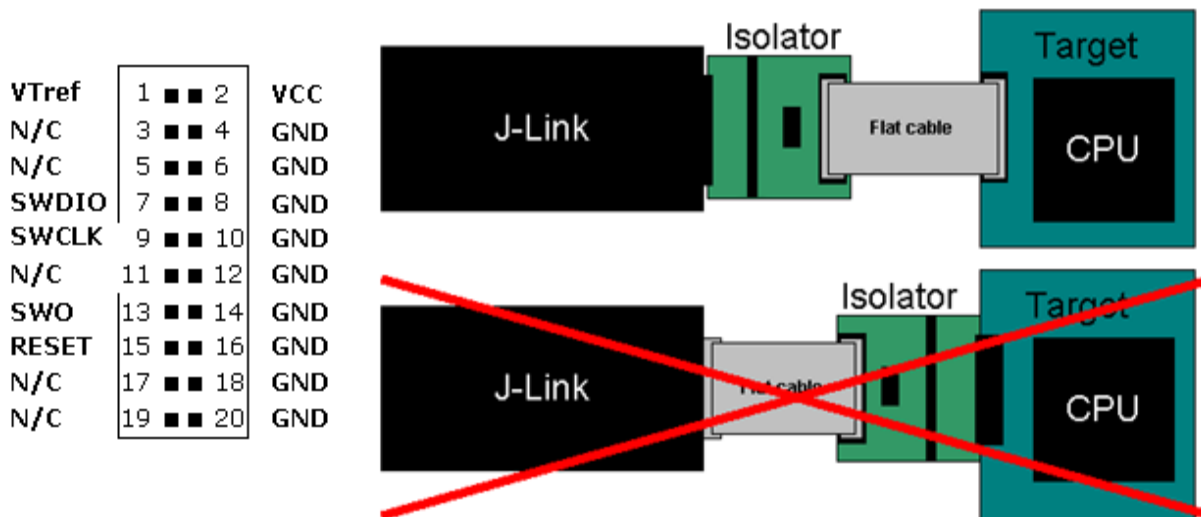

The Emulator side of the Isolator is plugged directly into the Emulator. The Target side is connected to the target via a 20-pin flat cable.

Pin	Signal	Type	Description
1	VCC	Input	The target side of the isolator draws power over this pin.
2	VCC	Input	The target side of the isolator draws power over this pin.
3	N/C	N/C	This pin is not connected on the target side of the isolator.
5	N/C	N/C	This pin is not connected on the target side of the isolator.
7	SWDIO	I/O	Bi-directional data pin of SWD. This pin should be pulled high on the target. Typically connected to SWDIO on target CPU.
9	SWCLK	Output	SWD clock signal to target CPU. It is recommended that this pin is pulled to a defined state on the target board. Typically connected to SWCLK on target CPU.
11	N/C	N/C	This pin is not connected on the target side of the isolator.
13	SWO	Input	SWD data output from target CPU. Typically connected to SWO on target CPU.
15	RESET	I/O	Target CPU reset signal. Typically connected to the RESET pin of the target CPU, which is typically called "nRST", "nRESET" or "RESET".
17	N/C	N/C	This pin is not connected on the target side of the isolator.
19	N/C	N/C	This pin is not connected on the target side of the isolator.

Pins 4, 6, 8, 10, 12, 14, 16, 18, 20 are GND pins connected to GND.

Using the SWD Isolator with J-Link

In order to use the Isolator, follow these steps:

- Plug the SWD Isolator directly into J-Link.
- Power J-Link.
- Make sure the green LED on the emulator side is lit. If it is not, please follow the instructions below
- Connect the target to the target side of the SWD Isolator
- If the target is powered, the green LED on the target side should be lit

The red LED on the target side is lit when a Target RESET is active (low).

Preparing J-Link to supply power

J-Link needs to supply 5V power to the emulator side of the isolator on pin 19. In order to do this, you may have to configure J-Link once as follows:

- Make sure that SEGGER J-Link software is installed on your machine. It can be downloaded from [here](#)
- Start J-Link Commander, which can be found under "Start -> Programs -> SEGGER -> J-Link ARM"
- Enter the following command to enable power supply via J-Link: *power on perm*
- Plug in the isolator: The green LED on the emulator side should now be lit

Using the SWD Isolator with another ARM emulator

The SWD Isolator has been designed for J-Link, but can also be used with other ARM emulators with the same pin-out. In this case, you should make sure that 5V are supplied to pin 19 of the emulator connector and that your emulator is not damaged when applying 5V to this pin. **Do this at your own risk!**



element14

EN - For pricing and availability in your local country please visit one of the below links:

DE - Informationen zu Preisen und Verfügbarkeit in Ihrem Land erhalten Sie über die unten aufgeführten Links:

FR - Pour connaître les tarifs et la disponibilité dans votre pays, cliquez sur l'un des liens suivants:

[8.07.01 SWD ISOLATOR](#)

EN

This Datasheet is presented by
the manufacturer

DE

Dieses Datenblatt wird vom
Hersteller bereitgestellt

FR

Cette fiche technique est
présentée par le fabricant