



EDUS391400-F14

R-410A

Engineering Data

FXFQ-TVJU

**Ceiling Mounted Cassette
(Round Flow with Sensing) Type**



FXFQ-TVJU

Ceiling Mounted Cassette (Round Flow with Sensing) Type

1. Specifications	2
2. Dimensions (with Decoration Panel)	5
3. Dimensions (with Self Clean Panel)	8
4. Piping Diagrams	11
5. Wiring Diagrams	12
6. Electric Characteristics	13
7. Safety Devices Setting	14
8. Capacity Tables	15
8.1 Cooling Capacity	15
8.2 Heating Capacity	15
9. Sound Levels (Reference)	16
10. Center of Gravity	23
11. Installation Manual	24
12. Accessories	43
12.1 Optional Accessories (for Unit)	43
12.2 Optional Accessories (for Controls)	43
13. Detail of Optional Accessories	44
13.1 BYCQ125BGW1 — Self Cleaning Decoration Panel	44
13.2 KKHAP55A160 — L-shape Extension Pipe	57
13.3 KAFP554A160 — Replacement Filter for Self Cleaning Decoration Panel	58

1. Specifications

Ceiling Mounted Cassette (Round Flow with Sensing) Type

Model		FXFQ07TVJU		FXFQ09TVJU		FXFQ12TVJU		
Power supply		1 phase, 60Hz, 208/230V		1 phase, 60Hz, 208/230V		1 phase, 60Hz, 208/230V		
★1 ★3 Cooling capacity	Btu/h (kW)	7,500 (2.2)		9,500 (2.8)		12,000 (3.5)		
★2 ★3 Heating capacity	Btu/h (kW)	8,500 (2.5)		10,500 (3.1)		13,500 (4.0)		
Casing / Color		Galvanized steel plate		Galvanized steel plate		Galvanized steel plate		
Dimensions: (HxWxD)		in. (mm)		9-11/16x33-1/16x33-1/16 (246x840x840)		9-11/16x33-1/16x33-1/16 (246x840x840)		
Coil (Cross fin coil)	RowsxStagesxFPI	2x8x21		2x8x21		2x8x21		
	Face area	ft ² (m ²)		2.63 (0.244)		2.63 (0.244)		
Fan	Model		QTS48C15M		QTS48C15M		QTS48C15M	
	Type		Turbo fan		Turbo fan		Turbo fan	
	Motor output	W		48		48		
	Airflow rate (HH/H/L)	cfm (m ³ /min)		420/406/353 (11.9/11.5/10.0)		441/406/353 (12.5/11.5/10.0)		
	Drive		Direct drive		Direct drive		Direct drive	
Temperature control		Microprocessor thermostat for cooling and heating		Microprocessor thermostat for cooling and heating		Microprocessor thermostat for cooling and heating		
Sound absorbing thermal insulation material		Polyurethane form		Polyurethane form		Polyurethane form		
Weight	Lbs (kg)	42 (19)		42 (19)		42 (19)		
★4 Sound pressure levels (HH/H/L)	dB (A)	30.0/28.5/27.0		30.0/28.5/27.0		30.0/28.5/27.0		
★4 Sound power level	dB (A)	49		49		49		
Piping connections	Liquid pipes	in. (mm)		φ1/4 (φ6.4) (Flare connection)		φ1/4 (φ6.4) (Flare connection)		
	Gas pipes	in. (mm)		φ1/2 (φ12.7) (Flare connection)		φ1/2 (φ12.7) (Flare connection)		
	Drain pipe	in. (mm)		VP25 (External dia. 1-1/4 (32) Internal dia. 1 (25))		VP25 (External dia. 1-1/4 (32) Internal dia. 1 (25))		
Safety devices		Fuse		Fuse		Fuse		
Refrigerant control		Electronic expansion valve		Electronic expansion valve		Electronic expansion valve		
Connectable outdoor unit		R410A VRF series		R410A VRF series		R410A VRF series		
Standard accessories		Operation manual. Installation manual. Paper pattern for installation. Drain hose. Sealing pads. Clamps. Washers. Screws. Insulation for fitting. Clamp metal.		Operation manual. Installation manual. Paper pattern for installation. Drain hose. Sealing pads. Clamps. Washers. Screws. Insulation for fitting. Clamp metal.		Operation manual. Installation manual. Paper pattern for installation. Drain hose. Sealing pads. Clamps. Washers. Screws. Insulation for fitting. Clamp metal.		
Decoration panels (Option)	Model		BYCQ125B-W1/BYCQ125BGW1		BYCQ125B-W1/BYCQ125BGW1		BYCQ125B-W1/BYCQ125BGW1	
	Color		Fresh white		Fresh white		Fresh white	
	Dimensions: (HxWxD)		in. (mm)		2x37-3/8x37-3/8 / 5-1/8x37-3/8x37-3/8 (50x950x950 / 130x950x950)		2x37-3/8x37-3/8 / 5-1/8x37-3/8x37-3/8 (50x950x950 / 130x950x950)	
	Air filter		Resin net (with mold resistance)		Resin net (with mold resistance)		Resin net (with mold resistance)	
	Weight	Lbs (kg)	12.2/22.1 (5.5/10.0)		12.2/22.1 (5.5/10.0)		12.2/22.1 (5.5/10.0)	
Drawing No.				C: 3D086889A				

Notes:

- ★1. Nominal cooling capacities are based on the following conditions:
Return air temperature: 80.0°FDB (26.7°CDB), 67.0°FWB (19.4°CWB)
Outdoor temperature: 95.0°FDB (35.0°CDB)
Equivalent ref. piping length: 25ft (7.6m) (Horizontal)
- ★2. Nominal heating capacities are based on the following conditions:
Return air temperature: 70.0°FDB (21.1°CDB).
Outdoor temperature: 47.0°FDB (8.3°CDB), 43.0°FWB (6.1°CWB)
Equivalent ref. piping length: 25ft (7.6m) (Horizontal)
- ★3. Capacities are net, including a deduction for cooling (an addition for heating) for indoor fan motor heat.
- ★4. Anechoic chamber conversion value, measured under JIS conditions. During actual operation, these values may be higher as a result of installation conditions.
5. Refer to Electric Characteristics for the power input.

Ceiling Mounted Cassette (Round Flow with Sensing) Type

Model		FXFQ15TVJU		FXFQ18TVJU		FXFQ24TVJU			
Power supply		1 phase, 60Hz, 208/230V		1 phase, 60Hz, 208/230V		1 phase, 60Hz, 208/230V			
★1 ★3 Cooling capacity	Btu/h (kW)	15,000 (4.4)		18,000 (5.3)		24,000 (7.0)			
★2 ★3 Heating capacity	Btu/h (kW)	17,000 (5.0)		20,000 (5.9)		27,000 (7.9)			
Casing / Color		Galvanized steel plate		Galvanized steel plate		Galvanized steel plate			
Dimensions: (HxWxD)		in. (mm)		9-11/16x33-1/16x33-1/16 (246x840x840)		9-11/16x33-1/16x33-1/16 (246x840x840)			
Coil (Cross fin coil)	Rows×Stages×FPI	2x8x21		3x(12+15x2)x(20+21x2)		3x(12+15x2)x(20+21x2)			
	Face area	ft ² (m ²)		2.63 (0.244)		4.59 (0.427)			
Fan	Model		QTS48C15M		QTS48C15M		QTS48C15M		
	Type		Turbo fan		Turbo fan		Turbo fan		
	Motor output	W		48		48			
	Airflow rate (HH/H/L)	cfm (m ³ /min)		512/459/388 (14.5/13.0/11.0)		742/618/477 (21.0/17.5/13.5)		777/618/477 (22.0/17.5/13.5)	
	Drive		Direct drive		Direct drive		Direct drive		
Temperature control		Microprocessor thermostat for cooling and heating		Microprocessor thermostat for cooling and heating		Microprocessor thermostat for cooling and heating			
Sound absorbing thermal insulation material		Polyurethane form		Polyurethane form		Polyurethane form			
Weight	Lbs (kg)	42 (19)		51 (23)		51 (23)			
★4 Sound pressure levels (HH/H/L)	dB (A)	31.0/29.0/27.0		35.5/32.0/28.0		36.0/32.0/28.0			
★4 Sound power level	dB (A)	51		53		53			
Piping connections	Liquid pipes	in. (mm)		φ1/4 (φ6.4) (Flare connection)		φ1/4 (φ6.4) (Flare connection)		φ3/8 (φ9.5) (Flare connection)	
	Gas pipes	in. (mm)		φ1/2 (φ12.7) (Flare connection)		φ1/2 (φ12.7) (Flare connection)		φ5/8 (φ15.9) (Flare connection)	
	Drain pipe	in. (mm)		VP25 (External dia. 1-1/4 (32) Internal dia. 1 (25))		VP25 (External dia. 1-1/4 (32) Internal dia. 1 (25))		VP25 (External dia. 1-1/4 (32) Internal dia. 1 (25))	
Safety devices		Fuse		Fuse		Fuse			
Refrigerant control		Electronic expansion valve		Electronic expansion valve		Electronic expansion valve			
Connectable outdoor unit		R410A VRF series		R410A VRF series		R410A VRF series			
Standard accessories		Operation manual. Installation manual. Paper pattern for installation. Drain hose. Sealing pads. Clamps. Washers. Screws. Insulation for fitting. Clamp metal.		Operation manual. Installation manual. Paper pattern for installation. Drain hose. Sealing pads. Clamps. Washers. Screws. Insulation for fitting. Clamp metal.		Operation manual. Installation manual. Paper pattern for installation. Drain hose. Sealing pads. Clamps. Washers. Screws. Insulation for fitting. Clamp metal.			
Decoration panels (Option)	Model		BYCQ125B-W1/BYCQ125BGW1		BYCQ125B-W1/BYCQ125BGW1		BYCQ125B-W1/BYCQ125BGW1		
	Color		Fresh white		Fresh white		Fresh white		
	Dimensions: (HxWxD)		in. (mm)		2x37-3/8x37-3/8 / 5-1/8x37-3/8x37-3/8 (50x950x950 / 130x950x950)		2x37-3/8x37-3/8 / 5-1/8x37-3/8x37-3/8 (50x950x950 / 130x950x950)		
	Air filter		Resin net (with mold resistance)		Resin net (with mold resistance)		Resin net (with mold resistance)		
	Weight	Lbs (kg)	12.2/22.1 (5.5/10.0)		12.2/22.1 (5.5/10.0)		12.2/22.1 (5.5/10.0)		
Drawing No.				C: 3D086889A					

Notes:

- ★1. Nominal cooling capacities are based on the following conditions:
Return air temperature: 80.0°FDB (26.7°CDB), 67.0°FWB (19.4°CWB)
Outdoor temperature: 95.0°FDB (35.0°CDB)
Equivalent ref. piping length: 25ft (7.6m) (Horizontal)
- ★2. Nominal heating capacities are based on the following conditions:
Return air temperature: 70.0°FDB (21.1°CDB)
Outdoor temperature: 47.0°FDB (8.3°CDB), 43.0°FWB (6.1°CWB)
Equivalent ref. piping length: 25ft (7.6m) (Horizontal)
- ★3. Capacities are net, including a deduction for cooling (an addition for heating) for indoor fan motor heat.
- ★4. Anechoic chamber conversion value, measured under JIS conditions. During actual operation, these values may be higher as a result of installation conditions.
- 5. Refer to Electric Characteristics for the power input.

Ceiling Mounted Cassette (Round Flow with Sensing) Type

Model		FXFQ30TVJU		FXFQ36TVJU		FXFQ48TVJU			
Power supply		1 phase, 60Hz, 208/230V		1 phase, 60Hz, 208/230V		1 phase, 60Hz, 208/230V			
★1 ★3 Cooling capacity	Btu/h (kW)	30,000 (8.8)		36,000 (10.6)		48,000 (14.1)			
★2 ★3 Heating capacity	Btu/h (kW)	34,000 (10.0)		40,000 (11.7)		54,000 (15.8)			
Casing / Color		Galvanized steel plate		Galvanized steel plate		Galvanized steel plate			
Dimensions: (HxWxD)		in. (mm)		11-5/16x33-1/16x33-1/16 (288x840x840)		11-5/16x33-1/16x33-1/16 (288x840x840)			
Coil (Cross fin coil)	RowsxStagesxFPI	3x18x(20+21x2)		3x18x(20+21x2)		3x18x(20+21x2)			
	Face area	ft ² (m ²)		5.92 (0.550)		5.92 (0.550)			
Fan	Model		QTS48C15M		QTS48C15M		QTS48C15M		
	Type		Turbo fan		Turbo fan		Turbo fan		
	Motor output	W		106		106			
	Airflow rate (HH/H/L)	cfm (m ³ /min)		1,112/918/671 (31.5/26.0/19.0)		1,165/918/671 (33.0/26.0/19.0)		1,218/971/742 (34.5/27.5/21.0)	
	Drive		Direct drive		Direct drive		Direct drive		
Temperature control		Microprocessor thermostat for cooling and heating		Microprocessor thermostat for cooling and heating		Microprocessor thermostat for cooling and heating			
Sound absorbing thermal insulation material		Polyurethane form		Polyurethane form		Polyurethane form			
Weight	Lbs (kg)		58 (26)		58 (26)		58 (26)		
★4 Sound pressure levels (HH/H/L)	dB (A)		43.5/38.0/32.0		44.0/38.0/32.0		45.0/40.0/35.0		
★4 Sound power level	dB (A)		60		60		61		
Piping connections	Liquid pipes	in. (mm)		φ3/8 (φ9.5) (Flare connection)		φ3/8 (φ9.5) (Flare connection)		φ3/8 (φ9.5) (Flare connection)	
	Gas pipes	in. (mm)		φ5/8 (φ15.9) (Flare connection)		φ5/8 (φ15.9) (Flare connection)		φ5/8 (φ15.9) (Flare connection)	
	Drain pipe	in. (mm)		VP25 (External dia. 1-1/4 (32) Internal dia. 1 (25))		VP25 (External dia. 1-1/4 (32) Internal dia. 1 (25))		VP25 (External dia. 1-1/4 (32) Internal dia. 1 (25))	
Safety devices		Fuse		Fuse		Fuse			
Refrigerant control		Electronic expansion valve		Electronic expansion valve		Electronic expansion valve			
Connectable outdoor unit		R410A VRF series		R410A VRF series		R410A VRF series			
Standard accessories		Operation manual. Installation manual. Paper pattern for installation. Drain hose. Sealing pads. Clamps. Washers. Screws. Insulation for fitting. Clamp metal.		Operation manual. Installation manual. Paper pattern for installation. Drain hose. Sealing pads. Clamps. Washers. Screws. Insulation for fitting. Clamp metal.		Operation manual. Installation manual. Paper pattern for installation. Drain hose. Sealing pads. Clamps. Washers. Screws. Insulation for fitting. Clamp metal.			
Decoration panels (Option)	Model		BYCQ125B-W1/BYCQ125BGW1		BYCQ125B-W1/BYCQ125BGW1		BYCQ125B-W1/BYCQ125BGW1		
	Color		Fresh white		Fresh white		Fresh white		
	Dimensions: (HxWxD)		in. (mm)		2x37-3/8x37-3/8 / 5-1/8x37-3/8x37-3/8 (50x950x950 / 130x950x950)		2x37-3/8x37-3/8 / 5-1/8x37-3/8x37-3/8 (50x950x950 / 130x950x950)		
	Air filter		Resin net (with mold resistance)		Resin net (with mold resistance)		Resin net (with mold resistance)		
	Weight	Lbs (kg)		12.2/22.1 (5.5/10.0)		12.2/22.1 (5.5/10.0)		12.2/22.1 (5.5/10.0)	
Drawing No.				C: 3D08689A					

Notes:

- ★1. Nominal cooling capacities are based on the following conditions:
Return air temperature: 80.0°FDB (26.7°CDB), 67.0°FWB (19.4°CWB)
Outdoor temperature: 95.0°FDB (35.0°CDB)
Equivalent ref. piping length: 25ft (7.6m) (Horizontal)
- ★2. Nominal heating capacities are based on the following conditions:
Return air temperature: 70.0°FDB (21.1°CDB)
Outdoor temperature: 47.0°FDB (8.3°CDB), 43.0°FWB (6.1°CWB)
Equivalent ref. piping length: 25ft (7.6m) (Horizontal)
- ★3. Capacities are net, including a deduction for cooling (an addition for heating) for indoor fan motor heat.
- ★4. Anechoic chamber conversion value, measured under JIS conditions. During actual operation, these values may be higher as a result of installation conditions.
5. Refer to Electric Characteristics for the power input.

2. Dimensions (with Decoration Panel)

FXFQ07TVJU / FXFQ09TVJU / FXFQ12TVJU / FXFQ15TVJU / FXFQ18TVJU

Unit: in. (mm)

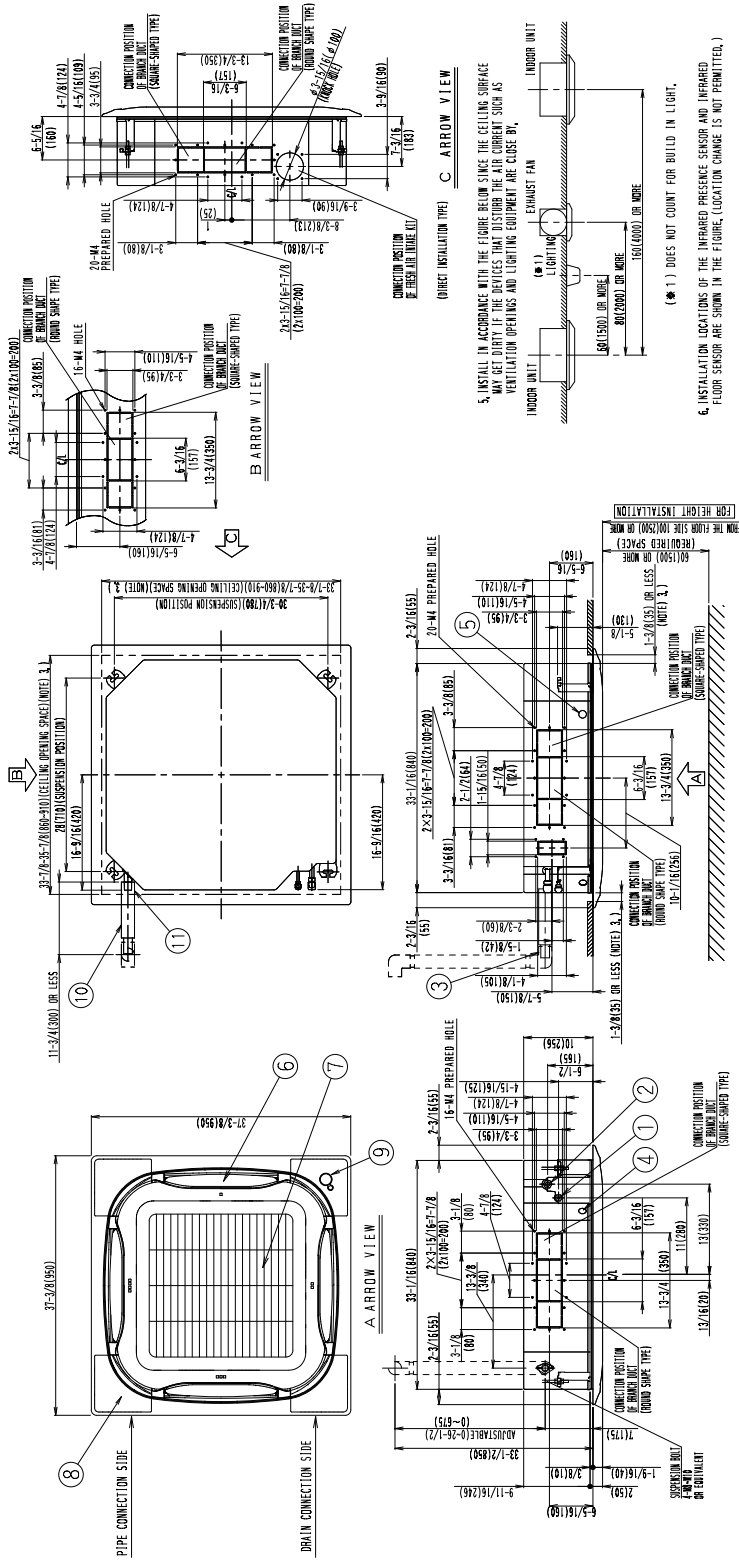

1	1 DRAIN HOSE CONNECTION	VP20 (OD φ 1 (φ 26))
1	0 DRAIN HOSE (ACCESSORY)	
9	SENSOR	INFRARED PRESENCE SENSOR INFRARED FLOOR SENSOR
8	CORNER DECORATION COVER	
6	AIR-OUTLET	
5	CONNECTION WIRING / REMOTE CONTROL WIRING CONNECTION	
4	POWER-SOURCE WIRING AND A UNIT WIRING CONNECTION	
3	DRAIN PIPE CONNECTION	VP25 (OD φ 1-1/4" (φ 32))
2	GAS PIPE CONNECTION	φ 3/8" (φ 10)
1	LIQUID PIPE CONNECTION	φ 3/8" (φ 10)
ITEM	PART NAME	REMARK

C: 3D08690B

FXFQ24TVJU

Unit: in. (mm)

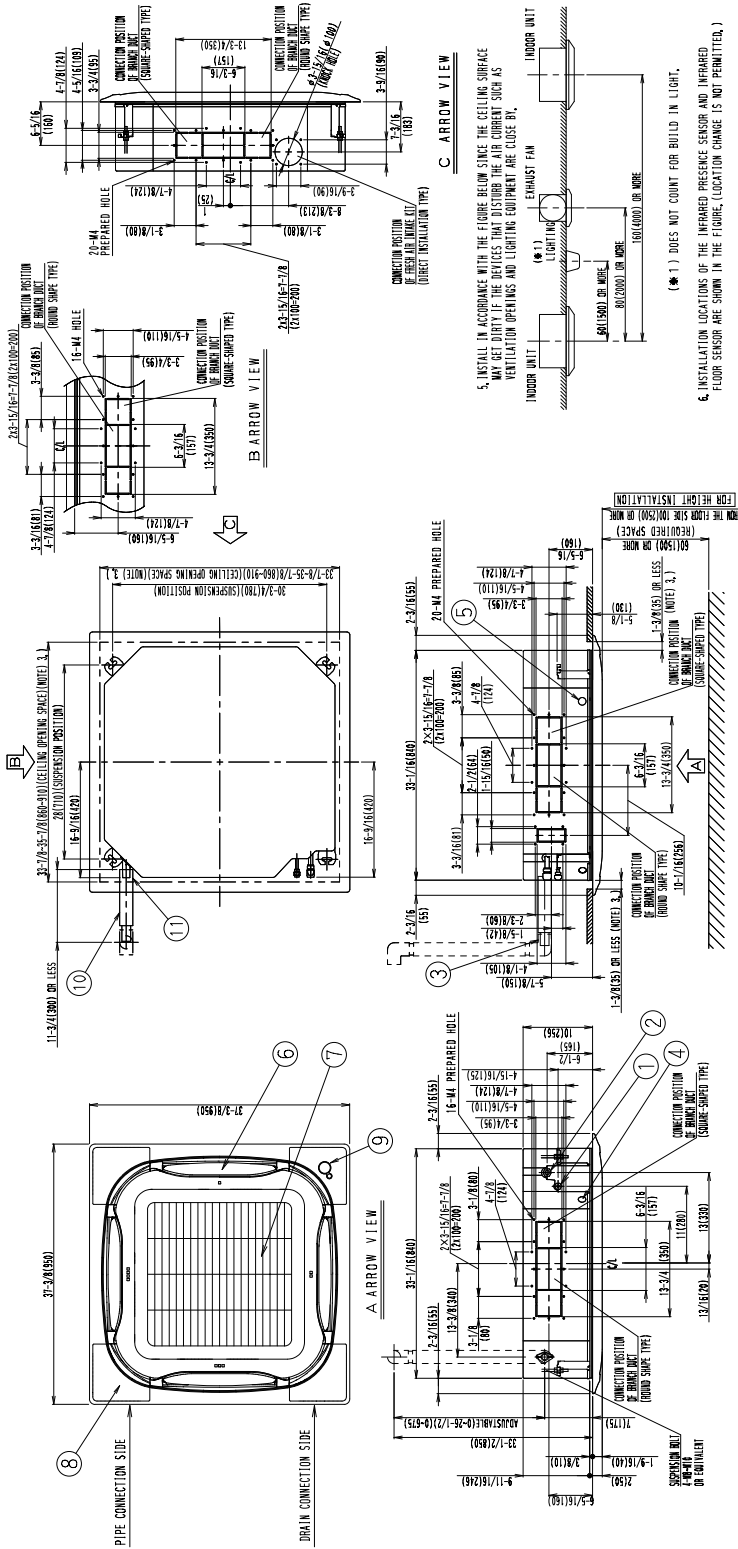

ITEM	PART NAME	REMARK
1	DRAIN HOSE CONNECTION	VP25 (OD φ 1 (φ 26.7))
1	DRAIN HOSE (ACCESSORY)	
9	SENSOR	INFRARED PRESENCE SENSOR INFRARED FLOOR SENSOR
8	CORNER DECORATION COVER	
6	AIR-OUTLET	
5	CONNECTION WIRING / REMOTE CONTROL WIRING CONNECTION	
4	POWER-SOURCE WIRING AND A UNIT WIRING CONNECTION	
3	DRAIN PIPE CONNECTION	VP25 (OD φ 1-1/4 (φ 32.7)) φ 1-1/4 (φ 32.7) (MAXIMUM) φ 1-1/4 (φ 32.7)
1	LIQUID PIPE CONNECTION	

C: 3D086962B

NOTE 1. STICKING LOCATION FOR MANUFACTURER'S LABEL
 2. WHEN THE TEMPERATURE AND HUMIDITY IN THE CEILING EXCEED 86°F (30°C) AND RH 80% OR THE FRESH AIR IS INTRODUCED INTO THE CEILING OR THE UNIT CONTINUES 24 HOUR OPERATION, AN ADDITIONAL INSULATION (THICKNESS 2/8"(6mm) OR MORE OF GLASSWOL OR POLYURETHANE FORM) IS REQUIRED.
 3. THROUGH THE INSTALLATION IS ACCEPTABLE UP TO MAXIMUM OF 95-7/8(243MM) SQUARE CEILING OPENING, BUT THE PANEL OVERLAP ALLOWANCE CAN BE ENSURED.
 4. DO NOT PLACE ANYTHING SENSITIVE TO MOISTURE UNDER THE INDOOR UNIT. THE OUTLETS IS CLOGGED, OR THE AIR FILTER IS DIRTY.

FXFQ30TVJU / FXFQ36TVJU / FXFQ48TVJU

Unit: in. (mm)

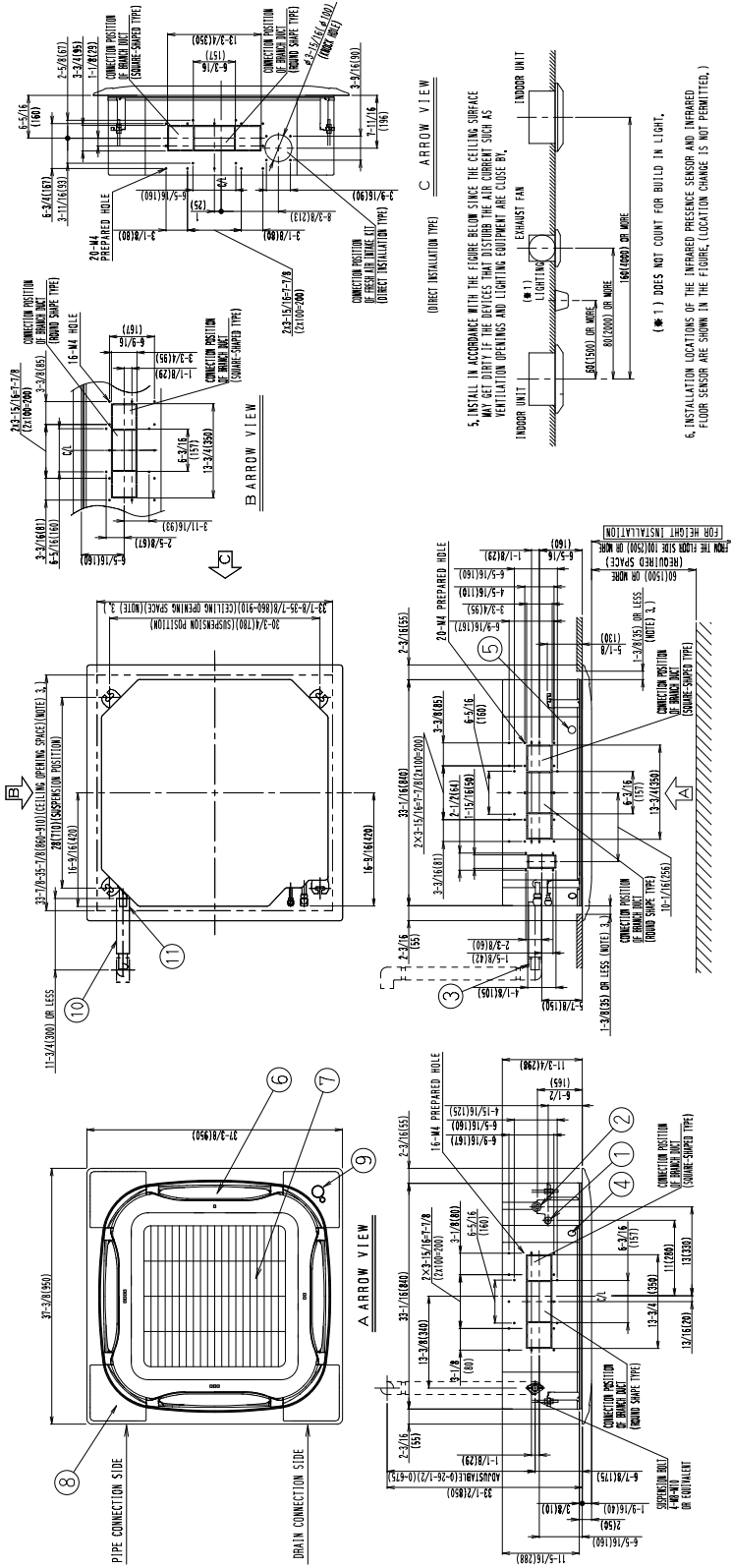

ITEM	PART NAME	REMARK
1	1 DRAIN HOSE CONNECTION	VP20 (OD φ 1 (φ 26))
1	0 DRAIN HOSE (ACCESSORY)	
9	SENSOR	INFRARED PRESENCE SENSOR INFRARED FLOOR SENSOR
8	CORNER DECORATION COVER	
7	SUCTION GRILLE	
6	AIR-OUTLET	
5	CONNECTION WIRING / REMOTE CONTROL WIRING CONNECTION	
4	POWER-SOURCE WIRING AND A UNIT WIRING CONNECTION	
3	DRAIN PIPE CONNECTION	VP25 (OD φ 1-1/4 (φ 32)) φ 1-1/4 (φ 32) (SEAL) φ 1-1/4 (φ 32) (SEAL)
2	GAS PIPE CONNECTION	
1	LIQUID PIPE CONNECTION	

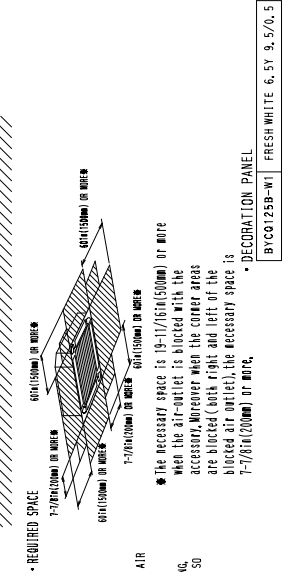

NOTE 1. STOCKING LOCATION: FOR MANUFACTURER'S LABEL
SUCTION GRILLE: INNER SIDE OF ELECTRIC COMPONENTS BOX'S LID SURFACE
MANUFACTURER'S LABEL FOR DECORATION PANEL:
DECORATION PANEL'S CORNER DECORATION COVER: INNER SURFACE
2. WHEN THE TEMPERATURE AND HUMIDITY IN THE CEILING EXCEED 86°F (30°C) AND RH 80% OR THE FRESH AIR IS INDICATED INTO THE CEILING OR THE UNIT CONTAINS 24 HOUR OPERATION, AN ADDITIONAL INSULATION (THICKNESS 3/8" (10mm) OR MORE OF GLASSWOL OR POLYURETHANE FOAM) IS REQUIRED.
3. INSULATION IS ACCEPTABLE UP TO MAXIMUM OF 35-7/8" (910mm) SQUARE CEILING OPENING. KEEP THE PLASTER OVERUP 1-3/8" (35mm) OR LESS BETWEEN THE INDOOR UNIT AND THE CEILING OPENING.
4. DO NOT PLACE ANYTHING SENSITIVE TO MOISTURE UNDER THE INDOOR UNIT. THE OUTLETS CONDENSATION MAY FORM WHEN HUMIDITY IS 80% OR MORE. THE OUTLETS CLOGGED, OR THE AIR FILTER IS DIRTY.

ITEM	PART NAME	REMARK
1	1 DRAIN HOSE CONNECTION	VP20 (OD φ 1 (φ 26))
1	0 DRAIN HOSE (ACCESSORY)	
9	SENSOR	INFRARED PRESENCE SENSOR INFRARED FLOOR SENSOR
8	CORNER DECORATION COVER	
7	SUCTION GRILLE	
6	AIR-OUTLET	
5	CONNECTION WIRING / REMOTE CONTROL WIRING CONNECTION	
4	POWER-SOURCE WIRING AND A UNIT WIRING CONNECTION	
3	DRAIN PIPE CONNECTION	VP25 (OD φ 1-1/4 (φ 32)) φ 1-1/4 (φ 32) (SEAL) φ 1-1/4 (φ 32) (SEAL)
2	GAS PIPE CONNECTION	
1	LIQUID PIPE CONNECTION	

4. Piping Diagrams

FXFQ07TVJU / FXFQ09TVJU / FXFQ12TVJU / FXFQ15TVJU / FXFQ18TVJU / FXFQ24TVJU / FXFQ30TVJU / FXFQ36TVJU / FXFQ48TVJU

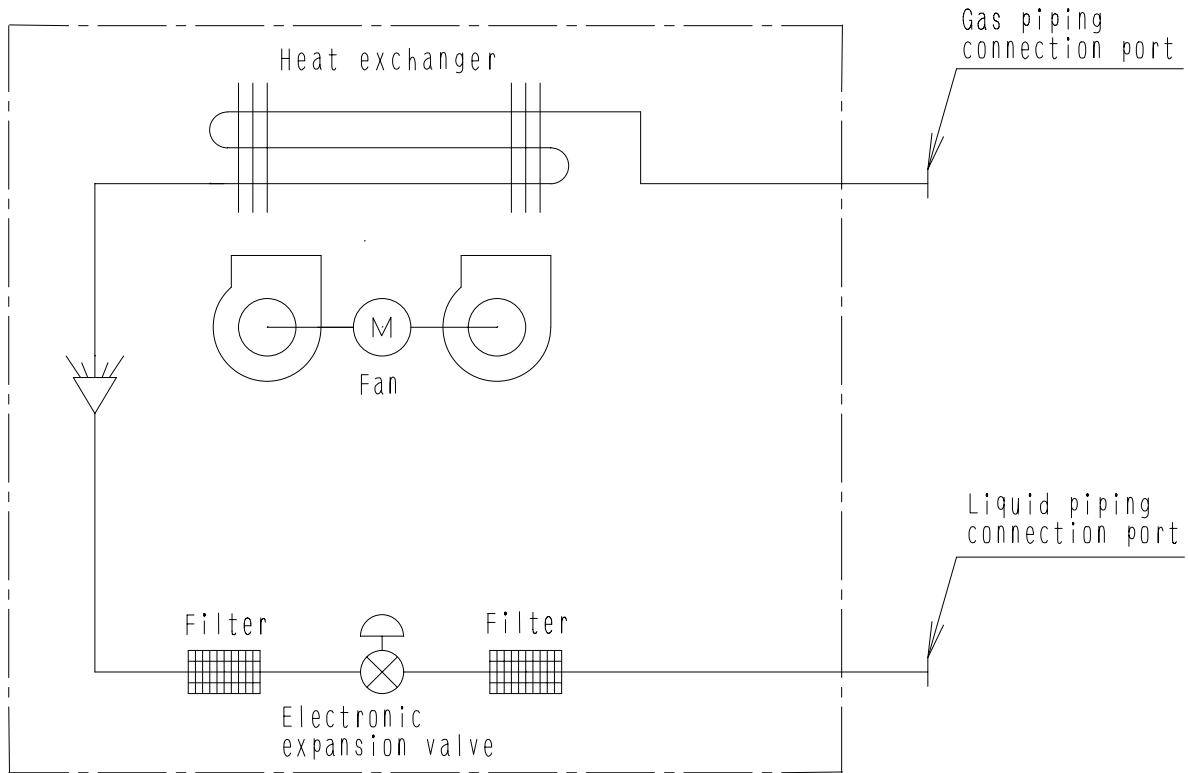

4D024460K

Unit: in. (mm)

Model	Gas	Liquid
FXFQ07TVJU / FXFQ09TVJU / FXFQ12TVJU / FXFQ15TVJU / FXFQ18TVJU	φ1/2 (12.7)	φ1/4 (6.4)
FXFQ24TVJU / FXFQ30TVJU / FXFQ36TVJU / FXFQ48TVJU	φ5/8 (15.9)	φ3/8 (9.5)

5. Wiring Diagrams

FXFQ07TVJU / FXFQ09TVJU / FXFQ12TVJU / FXFQ15TVJU / FXFQ18TVJU / FXFQ24TVJU / FXFQ30TVJU / FXFQ36TVJU / FXFQ48TVJU

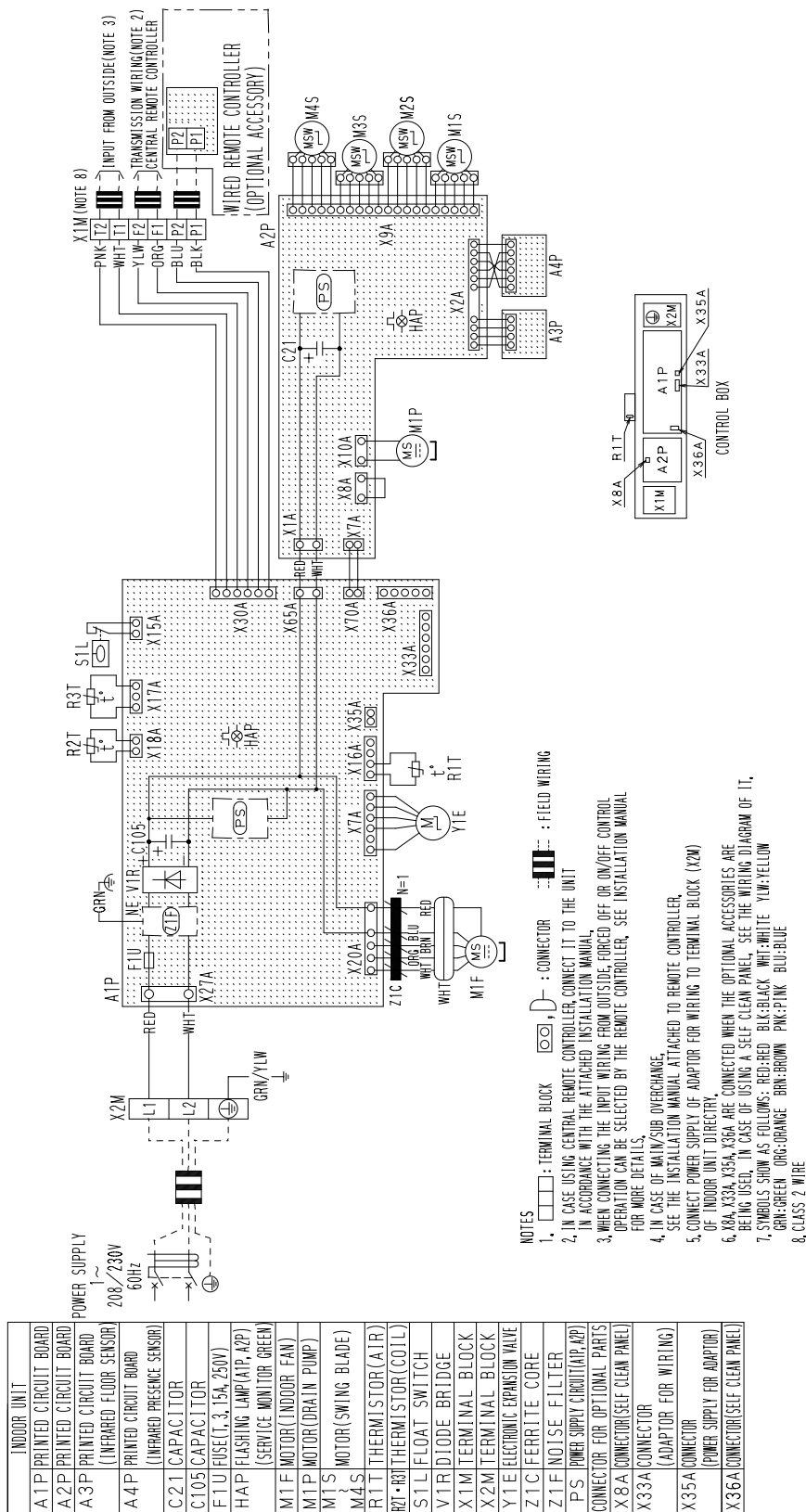

3D086460A

6. Electric Characteristics

Model	Power supply				IFM		Input (W)		
	Hz	Volts	Voltage range	MCA	MOP	KW	FLA	Cooling	Heating
FXFQ07TVJU	60	208V/230V	Max. 253V Min. 187V	0.3	15	0.048	0.2	28	24
FXFQ09TVJU				0.3	15	0.048	0.2	31	27
FXFQ12TVJU				0.3	15	0.048	0.2	31	27
FXFQ15TVJU				0.4	15	0.048	0.3	41	37
FXFQ18TVJU				0.6	15	0.048	0.5	76	72
FXFQ24TVJU				0.7	15	0.048	0.5	80	75
FXFQ30TVJU				1.3	15	0.106	1.0	169	161
FXFQ36TVJU				1.5	15	0.106	1.2	194	180
FXFQ48TVJU				1.8	15	0.106	1.4	219	199

Symbols :

MCA : Min. Circuit Amps (A)
 MOP : Max. Overcurrent Protective Device (A)
 KW : Fan Motor Rated Output(kW)
 FLA : Full Load Amps(A)
 IFM : Indoor Fan Motor

Note :

- Voltage range
Units are suitable for use on electrical systems where voltage supplied to unit terminals is not below or above listed range limits.
- Maximum allowable voltage unbalance between phases is 2%.
- MCA/MOP
 $MCA = 1.25 \times FLA$
 $MOP \leq 4 \times FLA$
 (Next lower standard fuse rating, Min. 15A)
- Select wire size based on the MCA.

C: 4D086936

7. Safety Devices Setting

Model		FXFQ07TVJU	FXFQ09TVJU	FXFQ12TVJU	FXFQ15TVJU	FXFQ18TVJU	FXFQ24TVJU	FXFQ30TVJU	FXFQ36TVJU	FXFQ48TVJU
Printed circuit board fuse		250V 3.15A	250V 3.15A	250V 3.15A	250V 3.15A	250V 3.15A	250V 3.15A	250V 3.15A	250V 3.15A	250V 3.15A
Drain pump thermal fuse	°F (°C)	-	-	-	-	-	-	-	-	-
Fan motor thermal protector	°F (°C)	-	-	-	-	-	-	-	-	-
Fan motor thermal fuse	°F (°C)	-	-	-	-	-	-	-	-	-

C: 3D086932A

8. Capacity Tables

8.1 Cooling Capacity

Model	Capacity indication	Indoor air temp. °FWB											
		61		64		67		70		72		75	
		TC	SHC	TC	SHC	TC	SHC	TC	SHC	TC	SHC	TC	SHC
		MBh	MBh	MBh	MBh	MBh	MBh	MBh	MBh	MBh	MBh	MBh	MBh
FXFQ-TVJU	07	5.9	5.9	6.7	6.5	7.5	6.7	7.6	6.8	7.8	6.4	7.9	6.3
	09	7.5	7.5	8.5	8.2	9.5	8.5	9.7	8.6	9.8	8.1	10.0	8.0
	12	9.5	8.2	10.7	8.8	12.0	9.7	12.2	9.5	12.4	9.0	12.6	8.6
	15	11.8	9.9	13.4	10.5	15.0	11.3	15.3	11.3	15.5	10.9	15.8	10.5
	18	14.2	13.9	16.1	15.5	18.0	16.1	18.4	16.1	18.6	15.4	18.9	15.1
	24	19.0	17.3	21.5	18.9	24.0	19.9	24.5	19.7	24.8	18.8	25.3	18.5
	30	23.7	19.4	26.8	21.1	30.0	22.3	30.6	22.2	31.0	21.3	31.6	20.6
	36	28.4	24.3	32.2	26.7	36.0	28.3	36.7	27.9	37.2	26.9	37.9	26.1
	48	37.9	30.2	43.0	33.1	48.0	35.0	49.0	34.8	49.6	33.2	50.5	31.9

TC: Total capacity: MBh
SHC: Sensible heat capacity: MBh

Notes: 1. These capacity tables are for use when selecting a *VRV* indoor unit. The actual capacity of the *VRV* system depends on factors such as the selected model of outdoor units, outdoor air temperature and piping length. Please confirm that the corrected capacity of the *VRV* system satisfies the required heat load.

2. shows rated condition.

CA14A023

8.2 Heating Capacity

Model	Capacity indication	Indoor air temp. °FDB									
		62		65		70		72		75	
		TC	TC	TC	TC	TC	TC	TC	TC		
		MBh	MBh	MBh	MBh	MBh	MBh	MBh	MBh		
FXFQ-TVJU	07	9.9	9.3	8.8	8.5	8.2	7.7				
	09	12.3	11.5	10.9	10.5	10.1	9.5				
	12	15.8	14.8	14.0	13.5	13.0	12.3				
	15	19.2	18.0	17.1	16.5	15.9	15.0				
	18	23.3	21.9	20.7	20.0	19.3	18.1				
	24	31.5	29.5	28.0	27.0	26.0	24.5				
	30	39.7	37.1	35.3	34.0	32.7	30.9				
	36	46.7	43.7	41.5	40.0	38.5	36.3				
	48	63.0	59.0	56.0	54.0	52.0	49.0				

TC: Total capacity: MBh

Notes: 1. These capacity tables are for use when selecting a *VRV* indoor unit. The actual capacity of the *VRV* system depends on factors such as the selected model of outdoor units, outdoor air temperature and piping length. Please confirm that the corrected capacity of the *VRV* system satisfies the required heat load.

2. shows rated condition.

CA14A023

9. Sound Levels (Reference)

FXFQ07TVJU / FXFQ09TVJU / FXFQ12TVJU

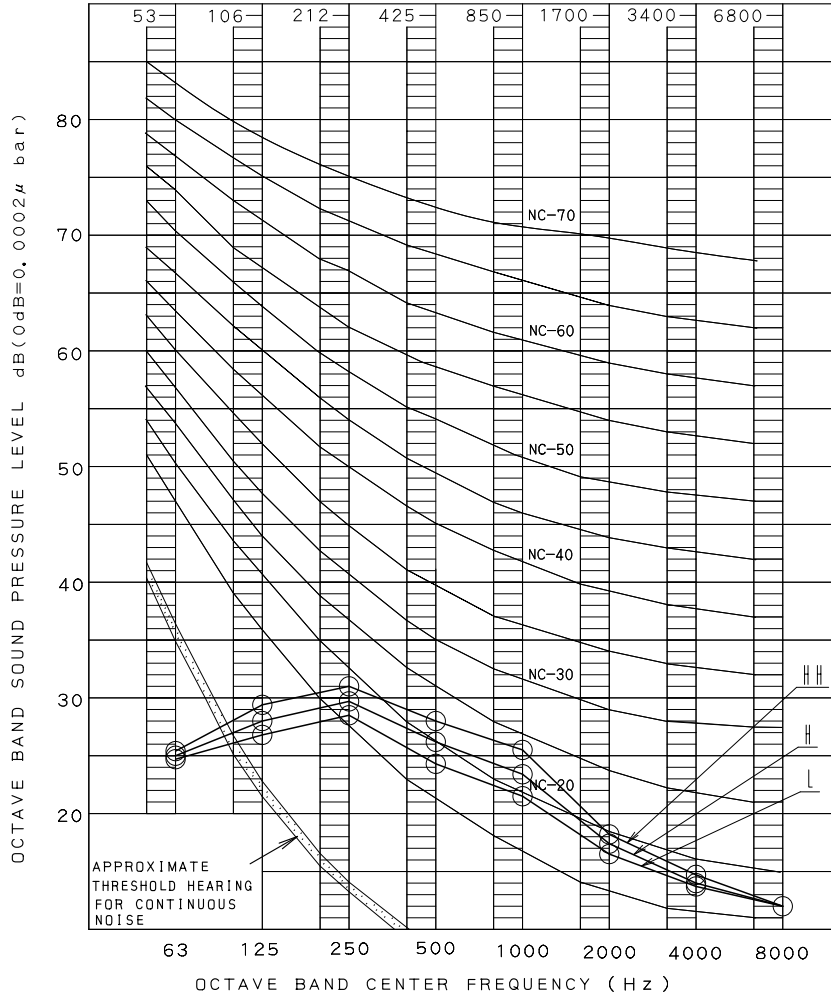

OVER ALL (dB)

SCALE	HH	H	L
A	30.0	28.5	27.0

(B, G, N IS ALREADY RECTIFIED)

OPERATING CONDITIONS

POWER SOURCE 208/230V 60Hz

COOLING RETURN AIR TEMPERATURE: 80.0 °F (26.7 °C) DB, 67.0 °F (19.4 °C) WB
 OUTDOOR TEMPERATURE: 95.0 °F (35.0 °C) DB, 75.0 °F (23.9 °C) WB

HEATING RETURN AIR TEMPERATURE: 70.0 °F (21.1 °C) DB, 60.0 °F (15.6 °C) WB
 OUTDOOR TEMPERATURE: 47.0 °F (8.3 °C) DB, 43.0 °F (6.1 °C) WB

LOCATION OF MICROPHONE

MEASURING PLACE

ANECHOIC CHAMBER

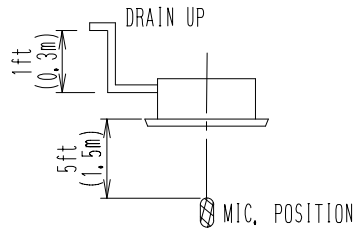

NOTE: Operation noise differs with operation and ambient conditions.

4D087472A

FXFQ15TVJU

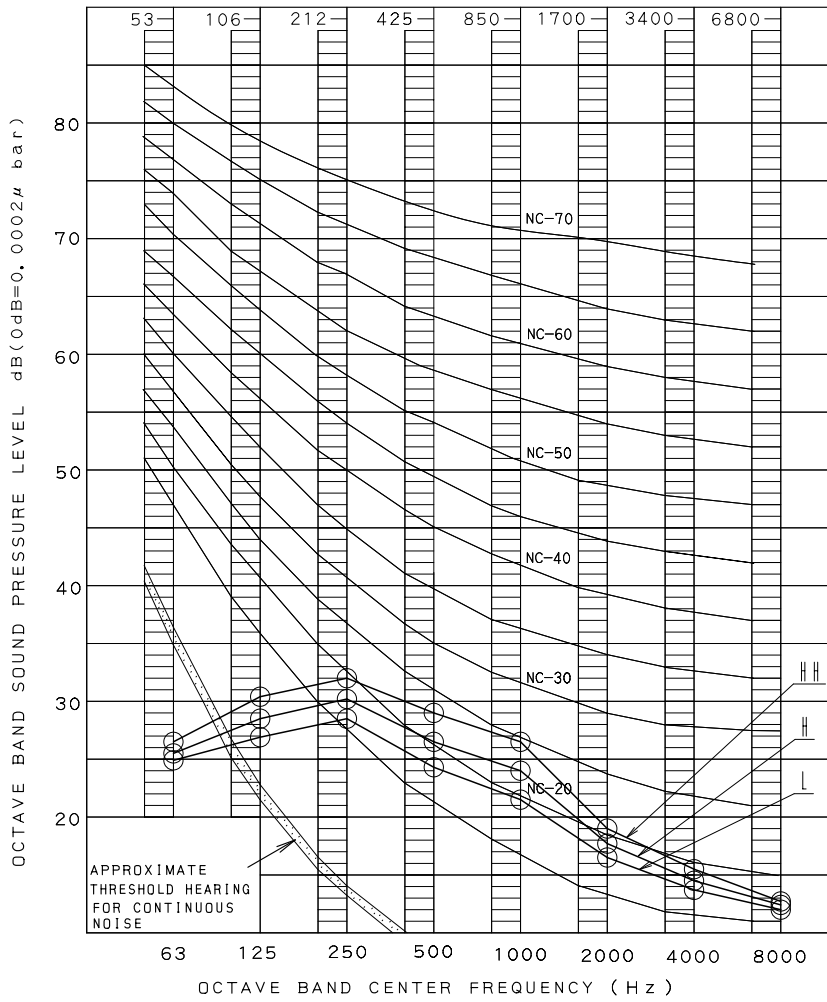

OVER ALL (dB)

SCALE	HH	H	L
A	31.0	29.0	27.0

(B, G, N IS ALREADY RECTIFIED)

OPERATING CONDITIONS

POWER SOURCE 208/230V 60Hz

COOLING RETURN AIR TEMPERATURE: 80.0 °F (26.7 °C) DB, 67.0 °F (19.4 °C) WB
 OUTDOOR TEMPERATURE: 95.0 °F (35.0 °C) DB, 75.0 °F (23.9 °C) WB

HEATING RETURN AIR TEMPERATURE: 70.0 °F (21.1 °C) DB, 60.0 °F (15.6 °C) WB
 OUTDOOR TEMPERATURE: 47.0 °F (8.3 °C) DB, 43.0 °F (6.1 °C) WB

LOCATION OF MICROPHONE

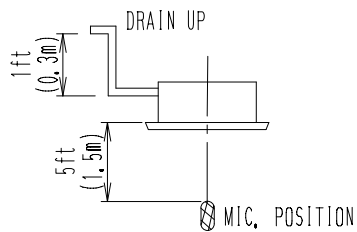

MEASURING PLACE

ANECHOIC CHAMBER

NOTE: Operation noise differs with operation and ambient conditions.

4D087473A

FXFQ18TVJU

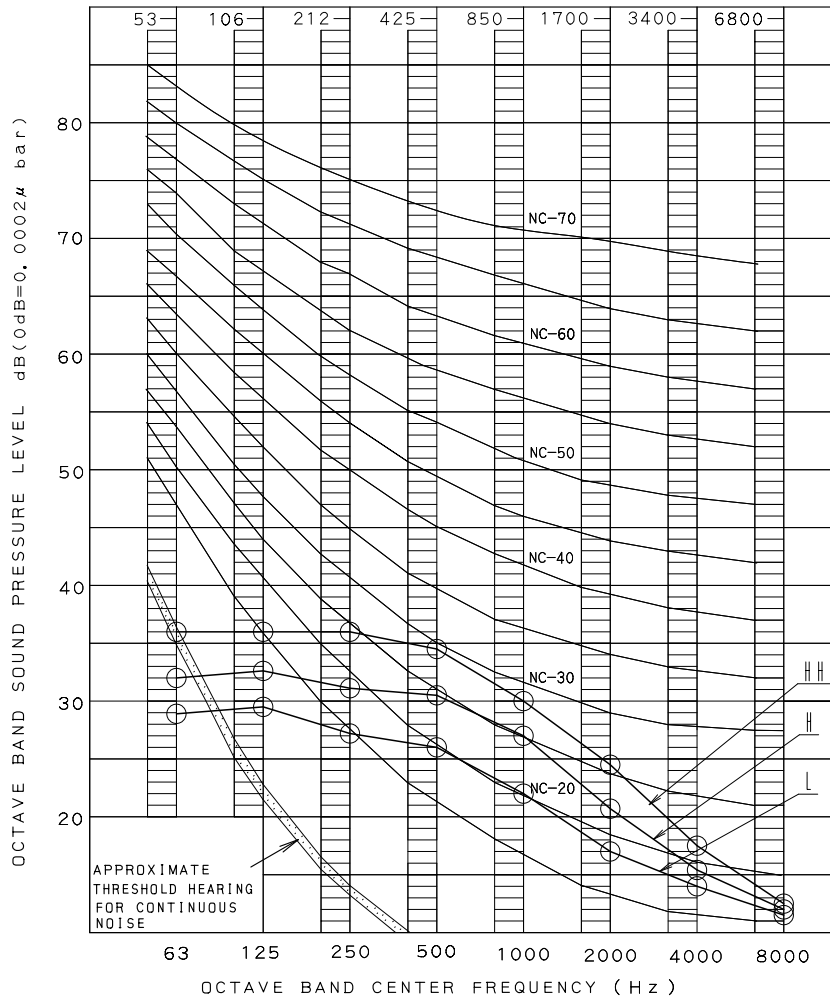

OVER ALL (dB)

SCALE	HH	H	L
A	35.5	32.0	28.0

OPERATING CONDITIONS

POWER SOURCE	208/230V 60Hz
COOLING	RETURN AIR TEMPERATURE: 80.0 °F (26.7 °C) DB, 67.0 °F (19.4 °C) WB OUTDOOR TEMPERATURE: 95.0 °F (35.0 °C) DB, 75.0 °F (23.9 °C) WB
HEATING	RETURN AIR TEMPERATURE: 70.0 °F (21.1 °C) DB, 60.0 °F (15.6 °C) WB OUTDOOR TEMPERATURE: 47.0 °F (8.3 °C) DB, 43.0 °F (6.1 °C) WB

(B. G. N IS ALREADY RECTIFIED)

MEASURING PLACE

ANECHOIC CHAMBER

LOCATION OF MICROPHONE

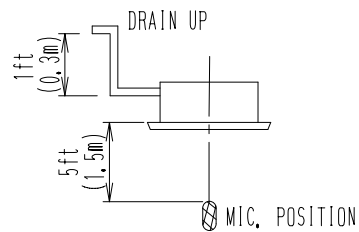

NOTE: Operation noise differs with operation and ambient conditions.

4D087483A

FXFQ24TVJU

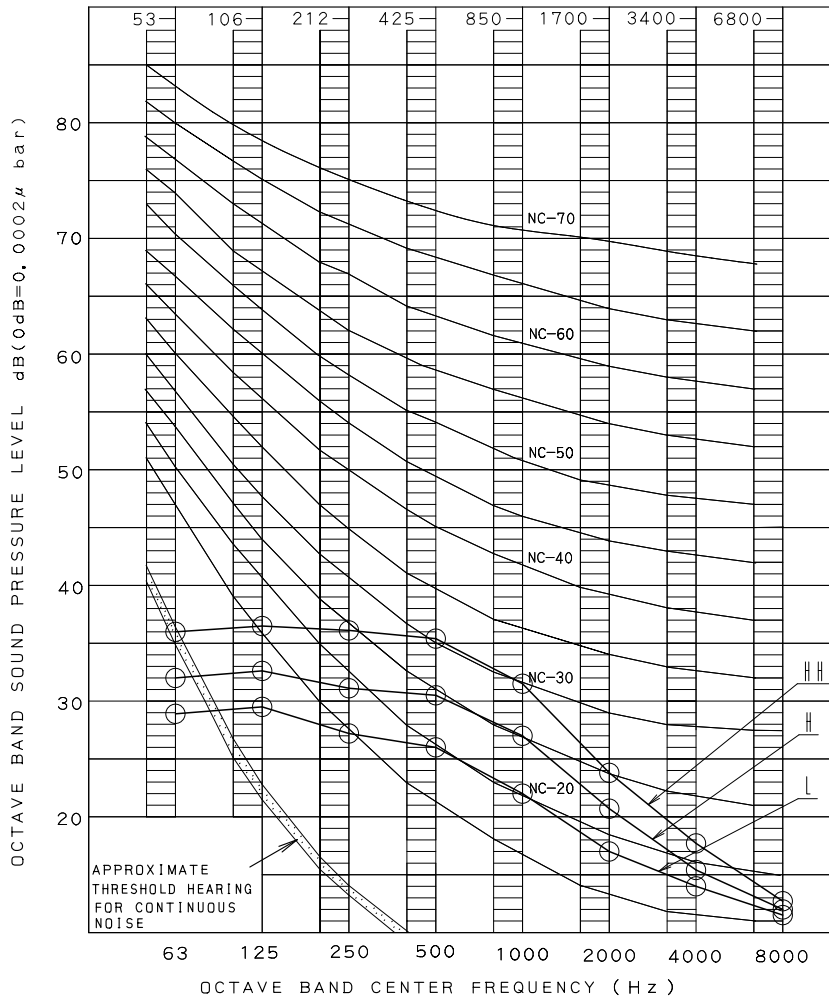

OVER ALL (dB)

SCALE	HH	H	L
A	36.0	32.0	28.0

(B, G, N IS ALREADY RECTIFIED)

OPERATING CONDITIONS

POWER SOURCE 208/230V 60Hz

COOLING RETURN AIR TEMPERATURE: 80.0 °F (26.7 °C) DB, 67.0 °F (19.4 °C) WB
 OUTDOOR TEMPERATURE: 95.0 °F (35.0 °C) DB, 75.0 °F (23.9 °C) WB

HEATING RETURN AIR TEMPERATURE: 70.0 °F (21.1 °C) DB, 60.0 °F (15.6 °C) WB
 OUTDOOR TEMPERATURE: 47.0 °F (8.3 °C) DB, 43.0 °F (6.1 °C) WB

LOCATION OF MICROPHONE

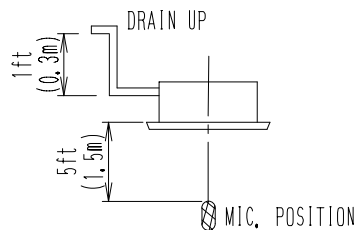

MEASURING PLACE

ANECHOIC CHAMBER

NOTE: Operation noise differs with operation and ambient conditions.

4D087474A

FXFQ30TVJU

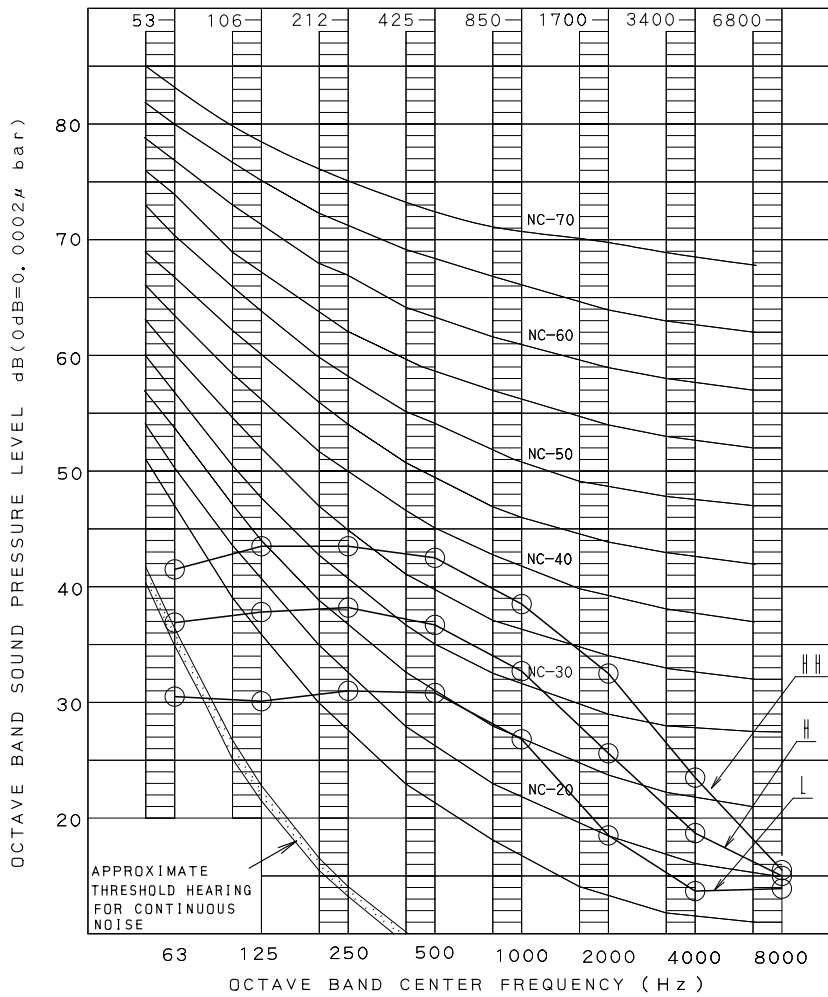

OVER ALL (dB)

SCALE	HH	H	L
A	43.5	38.0	32.0

(B, G, N IS ALREADY RECTIFIED)

OPERATING CONDITIONS

POWER SOURCE	208/230V 60Hz		
COOLING	RETURN AIR TEMPERATURE: 80.0 °F (26.7 °C)	DB, 67.0 °F (19.4 °C)	WB
	OUTDOOR TEMPERATURE: 95.0 °F (35.0 °C)	DB, 75.0 °F (23.9 °C)	WB
HEATING	RETURN AIR TEMPERATURE: 70.0 °F (21.1 °C)	DB, 60.0 °F (15.6 °C)	WB
	OUTDOOR TEMPERATURE: 47.0 °F (8.3 °C)	DB, 43.0 °F (6.1 °C)	WB

LOCATION OF MICROPHONE

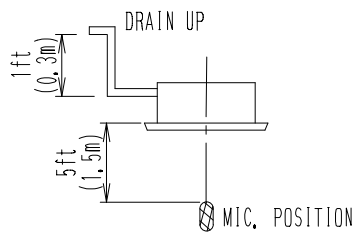

MEASURING PLACE

ANECHOIC CHAMBER

NOTE: Operation noise differs with operation and ambient conditions.

4D087479A

FXFQ36TVJU

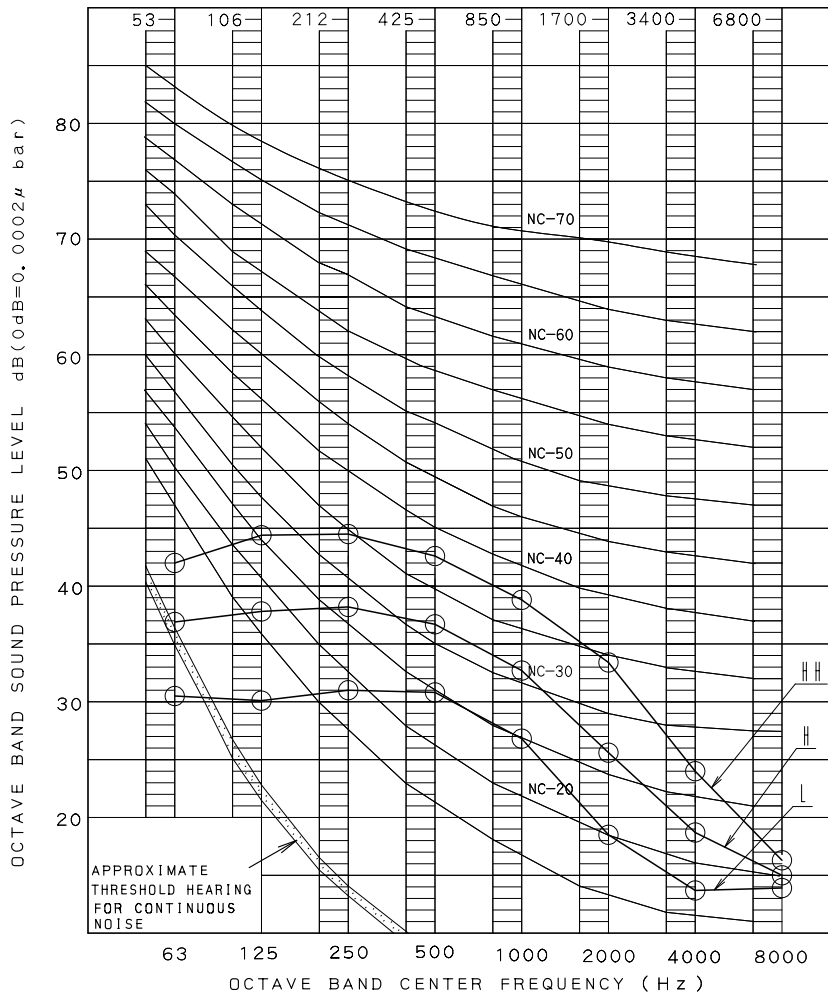

OVER ALL (dB)

SCALE	HH	H	L
A	44.0	38.0	32.0

(B. G. N IS ALREADY RECTIFIED)

OPERATING CONDITIONS

POWER SOURCE	208/230V 60Hz
COOLING	RETURN AIR TEMPERATURE: 80.0 °F (26.7 °C) DB, 67.0 °F (19.4 °C) WB OUTDOOR TEMPERATURE: 95.0 °F (35.0 °C) DB, 75.0 °F (23.9 °C) WB
HEATING	RETURN AIR TEMPERATURE: 70.0 °F (21.1 °C) DB, 60.0 °F (15.6 °C) WB OUTDOOR TEMPERATURE: 47.0 °F (8.3 °C) DB, 43.0 °F (6.1 °C) WB

LOCATION OF MICROPHONE

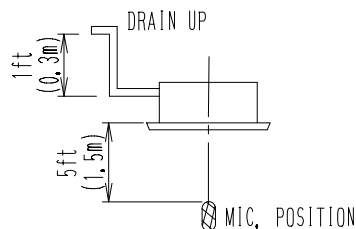

MEASURING PLACE

ANECHOIC CHAMBER

NOTE: Operation noise differs with operation and ambient conditions.

4D087475A

FXFQ48TVJU

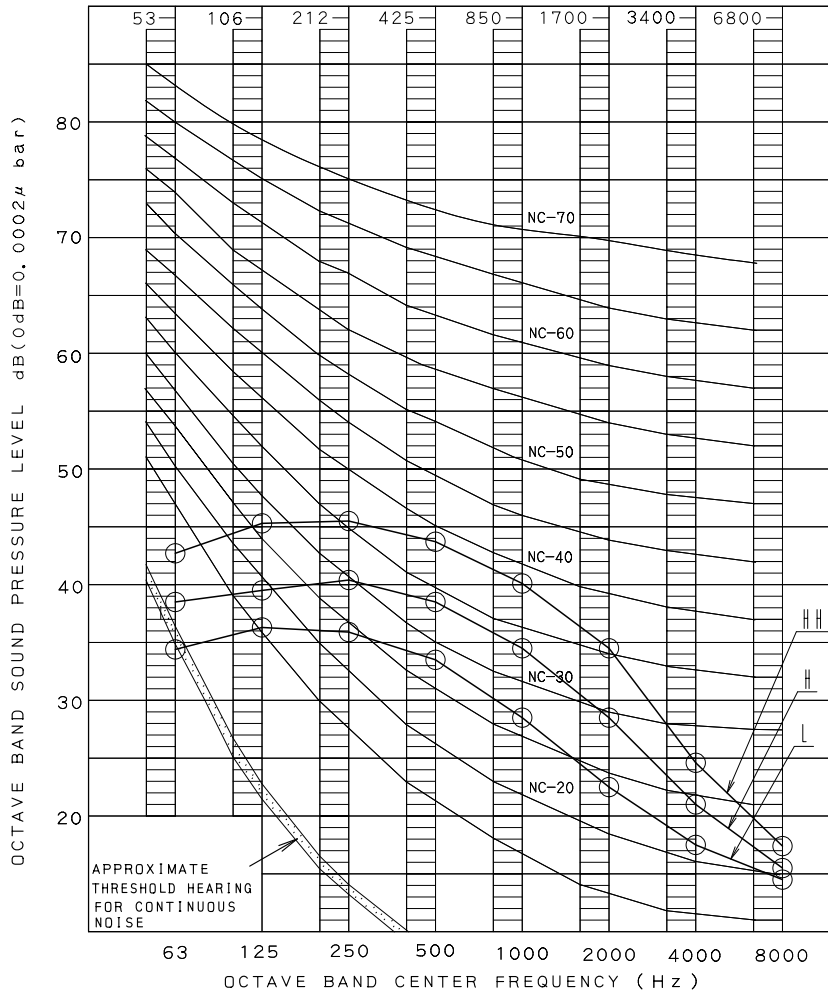

OVER ALL (dB)

SCALE	HH	H	L
A	45.0	40.0	35.0

(B, G, N IS ALREADY RECTIFIED)

OPERATING CONDITIONS

POWER SOURCE	208/230V 60Hz
COOLING	RETURN AIR TEMPERATURE: 80.0 °F (26.7 °C) DB, 67.0 °F (19.4 °C) WB OUTDOOR TEMPERATURE: 95.0 °F (35.0 °C) DB, 75.0 °F (23.9 °C) WB
HEATING	RETURN AIR TEMPERATURE: 70.0 °F (21.1 °C) DB, 60.0 °F (15.6 °C) WB OUTDOOR TEMPERATURE: 47.0 °F (8.3 °C) DB, 43.0 °F (6.1 °C) WB

LOCATION OF MICROPHONE

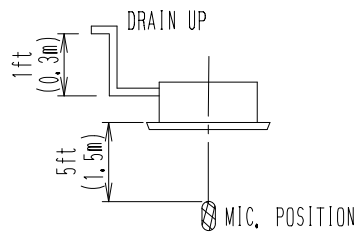

MEASURING PLACE

ANECHOIC CHAMBER

NOTE: Operation noise differs with operation and ambient conditions.

4D087476A

10. Center of Gravity

Unit: in. (mm)

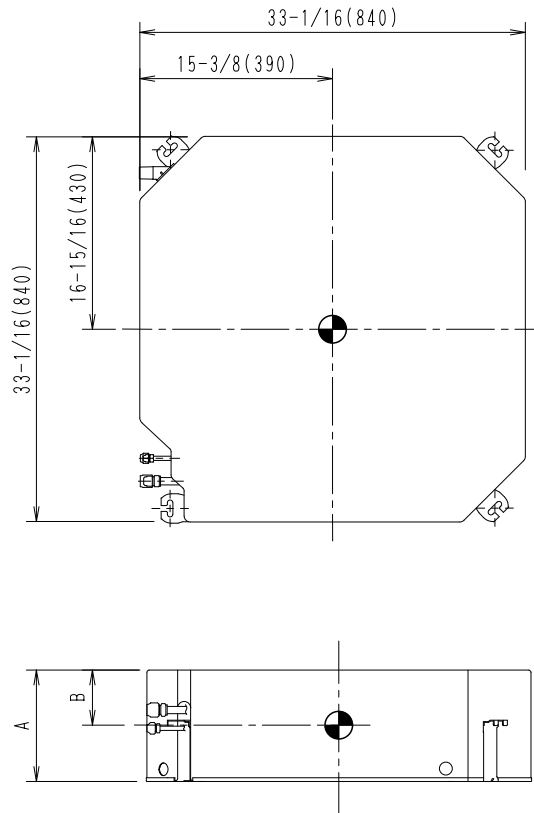





MODEL NAME	A	B
FXFQ07~24TVJU	9-11/16 (246)	3-9/16 (90)
FXFQ30~48TVJU	11-5/16 (288)	4-3/4 (120)

C: 4D070529C

11. Installation Manual

SAFETY CONSIDERATIONS

Read these **SAFETY CONSIDERATIONS for Installation** carefully before installing air conditioning equipment. After completing the installation, make sure that the unit operates properly during the startup operation. Instruct the customer on how to operate and maintain the unit. Inform customers that they should store this Installation Manual with the Operation Manual for future reference. Always use a licensed installer or contractor to install this product. Improper installation can result in water or refrigerant leakage, electrical shock, fire, or explosion. Meanings of **DANGER**, **WARNING**, **CAUTION**, and **NOTE** Symbols:

-  **DANGER**Indicates an imminently hazardous situation which, if not avoided, will result in death or serious injury.
-  **WARNING**Indicates a potentially hazardous situation which, if not avoided, could result in death or serious injury.
-  **CAUTION**Indicates a potentially hazardous situation which, if not avoided, may result in minor or moderate injury. It may also be used to alert against unsafe practices.
-  **NOTE**Indicates situations that may result in equipment or property-damage accidents only.

-
-  **DANGER**
- Refrigerant gas is heavier than air and replaces oxygen. A massive leak can lead to oxygen depletion, especially in basements, and an asphyxiation hazard could occur leading to serious injury or death.
 - Do not ground units to water pipes, gas pipes, telephone wires, or lightning rods as incomplete grounding can cause a severe shock hazard resulting in severe injury or death. Additionally, grounding to gas pipes could cause a gas leak and potential explosion causing severe injury or death.
 - If refrigerant gas leaks during installation, ventilate the area immediately. Refrigerant gas may produce toxic gas if it comes in contact with fire. Exposure to this gas could cause severe injury or death.
 - After completing the installation work, check that the refrigerant gas does not leak throughout the system.
 - Do not install unit in an area where flammable materials are present due to risk of explosions that can cause serious injury or death.
 - Safely dispose all packing and transportation materials in accordance with federal/state/local laws or ordinances. Packing materials such as nails and other metal or wood parts, including plastic packing materials used for transportation may cause injuries or death by suffocation.
-

 **WARNING**

- Only qualified personnel must carry out the installation work. Installation must be done in accordance with this installation manual. Improper installation may result in water leakage, electric shock, or fire.
 - When installing the unit in a small room, take measures to keep the refrigerant concentration from exceeding allowable safety limits. Excessive refrigerant leaks, in the event of an accident in a closed ambient space, can lead to oxygen deficiency.
 - Use only specified accessories and parts for installation work. Failure to use specified parts may result in water leakage, electric shocks, fire, or the unit falling.
 - Install the air conditioner or heat pump on a foundation strong enough that it can withstand the weight of the unit. A foundation of insufficient strength may result in the unit falling and causing injuries.
 - Take into account strong winds, typhoons, or earthquakes when installing. Improper installation may result in the unit falling and causing accidents.
 - Make sure that a separate power supply circuit is provided for this unit and that all electrical work is carried out by qualified personnel according to local, state and national regulations. An insufficient power supply capacity or improper electrical construction may lead to electric shocks or fire.
 - Make sure that all wiring is secured, that specified wires are used, and that no external forces act on the terminal connections or wires. Improper connections or installation may result in fire.
 - When wiring, position the wires so that the control box cover can be securely fastened. Improper positioning of the control box cover may result in electric shocks, fire, or the terminals overheating.
 - Before touching electrical parts, turn off the unit.
 - This equipment can be installed with a Ground-Fault Circuit Breaker (GFCI). Although this is a recognized measure for additional protection, with the earthing system in North America, a dedicated GFCI is not necessary.
 - Securely fasten the outdoor unit terminal cover (panel). If the terminal cover/panel is not installed properly, dust or water may enter the outdoor unit causing fire or electric shock.
 - When installing or relocating the system, keep the refrigerant circuit free from substances other than the specified refrigerant (R410A) such as air. Any presence of air or other foreign substance in the refrigerant circuit can cause an abnormal pressure rise or rupture, resulting in injury.
 - Do not change the setting of the protection devices. If the pressure switch, thermal switch, or other protection device is shorted and operated forcibly, or parts other than those specified by Daikin are used, fire or explosion may occur.
-

 **CAUTION**

- Do not touch the switch with wet fingers. Touching a switch with wet fingers can cause electric shock.
 - Do not allow children to play on or around the unit to prevent injury.
-

- Do not touch the refrigerant pipes during and immediately after operation as the refrigerant pipes may be hot or cold, depending on the condition of the refrigerant flowing through the refrigerant piping, compressor, and other refrigerant cycle parts. Your hands may suffer burns or frostbite if you touch the refrigerant pipes. To avoid injury, give the pipes time to return to normal temperature or, if you must touch them, be sure to wear proper gloves.
- Heat exchanger fins are sharp enough to cut. To avoid injury wear glove or cover the fins when working around them.
- Install drain piping to proper drainage. Improper drain piping may result in water leakage and property damage.
- Insulate piping to prevent condensation.
- Be careful when transporting the product.
- Do not turn off the power supply immediately after stopping operation. Always wait for at least 5 minutes before turning off the power supply. Otherwise, water leakage may occur.
- Do not use a charging cylinder. Using a charging cylinder may cause the refrigerant to deteriorate.
- Refrigerant R410A in the system must be kept clean, dry, and tight.
 - (a) Clean and Dry - Foreign materials (including mineral oils such as SUNISO oil or moisture) should be prevented from getting into the system.
 - (b) Tight - R410A does not contain any chlorine, does not destroy the ozone layer, and does not reduce the earth's protection against harmful ultraviolet radiation. R410A can contribute to the greenhouse effect if it is released. Therefore take proper measures to check for the tightness of the refrigerant piping installation. Read the chapter Refrigerant Piping Work and follow the procedures.
- Since R410A is a blend, the required additional refrigerant must be charged in its liquid state. If the refrigerant is charged in a state of gas, its composition can change and the system will not work properly.
- The indoor unit is for R410A. See the catalog for indoor models that can be connected. Normal operation is not possible when connected to other units.
- Remote controller (wireless kit) transmitting distance can be shorter than expected in rooms with electronic fluorescent lamps (inverter or rapid start types). Install the indoor unit far away from fluorescent lamps as much as possible.
- Indoor units are for indoor installation only. Outdoor units can be installed either outdoors or indoors.
- Do not install the air conditioner or heat pump in the following locations:
 - (a) Where a mineral oil mist or oil spray or vapor is produced, for example, in a kitchen. Plastic parts may deteriorate and fall off or result in water leakage.
 - (b) Where corrosive gas, such as sulfurous acid gas, is produced. Corroding copper pipes or soldered parts may result in refrigerant leakage.
 - (c) Near machinery emitting electromagnetic waves. Electromagnetic waves may disturb the operation of the control system and cause the unit to malfunction.
 - (d) Where flammable gas may leak, where there is carbon fiber, or ignitable dust suspension in the air, or where volatile flammables such as thinner or gasoline are handled. Operating the unit in such conditions can cause a fire.
- Take adequate measures to prevent the outdoor unit from being used as a shelter by small animals. Small animals making contact with electrical parts can cause malfunctions, smoke, or fire. Instruct the customer to keep the area around the unit clean.

—  NOTE —

- Install the power supply and transmission wires for the indoor and outdoor units at least 3.5 feet away from televisions or radios to prevent image interference or noise. Depending on the radio waves, a distance of 3.5 feet may not be sufficient to eliminate the noise.
 - Dismantling the unit, treatment of the refrigerant, oil and additional parts must be done in accordance with the relevant local, state, and national regulations.
 - Do not use the following tools that are used with conventional refrigerants: gauge manifold, charge hose, gas leak detector, reverse flow check valve, refrigerant charge base, vacuum gauge, or refrigerant recovery equipment.
 - If the conventional refrigerant and refrigerator oil are mixed in R410A, the refrigerant may deteriorate.
 - This air conditioner or heat pump is an appliance that should not be accessible to the general public.
 - As design pressure is 478 psi, the wall thickness of field-installed pipes should be selected in accordance with the relevant local, state, and national regulations.
-



FXFQ07TVJU	FXFQ24TVJU
FXFQ09TVJU	FXFQ30TVJU
FXFQ12TVJU	FXFQ36TVJU
FXFQ15TVJU	FXFQ48TVJU
FXFQ18TVJU	

VRV SYSTEM Inverter Air Conditioners

Installation Manual

CONTENTS

SAFETY CONSIDERATIONS.....	[i] [ii]
1. BEFORE INSTALLATION	2
2. SELECTION OF INSTALLATION LOCATION.....	3
3. PREPARATION BEFORE INSTALLATION	5
4. INSTALLATION OF INDOOR UNIT	5
5. REFRIGERANT PIPING WORK.....	7
6. DRAIN PIPING WORK	8
7. ELECTRIC WIRING WORK.....	11
8. MOUNTING DECORATION PANEL	15
9. FIELD SETTING AND TEST OPERATION.....	16





1. BEFORE INSTALLATION





When unpacking the indoor unit or moving the unit after unpacked, hold the hangers (4 places) and do not apply force to other parts (particularly refrigerant piping, drain piping and resin parts).





- Make sure to check in advance that the refrigerant to be used for installation work is R410A.
The air conditioner will not operate properly without the correct refrigerant.
- For installation of the outdoor unit, refer to the installation manual attached to the outdoor unit.
- Do not throw away the accessories until the installation work is completed.
- After the indoor unit is carried into the room, to avoid the indoor unit from getting damaged, take measures to protect the indoor unit with packing materials until the installation begins.
 - (1) Determine the route to carry the unit into the room.
 - (2) Do not unpack the unit until it is carried to the installation location.
Where unpacking is unavoidable, use a sling of soft material or protective plates together with a rope when lifting, to avoid damage or scratches to the indoor unit.
- Have the customer actually operate the air conditioner while looking at the operation manual.
Instruct the customer how to operate the air conditioner (particularly cleaning of the air filters, operation procedures, and temperature adjustment).
- For selection of installation location, use the installation pattern paper as reference.
- Do not use the air conditioner where in the salty atmosphere such as coastal areas, vehicles, vessels or the voltage fluctuation is frequent such as factories.
- Take off static electricity from the body when carrying out wiring and the control box lid is removed.
The electric parts may be damaged.



1-1 ACCESSORIES

Check if the following accessories are attached to the indoor unit.

Name	(1) Drain hose	(2) Metal clamp	(3) Washer for hanger	(4) Clamp
Quantity	1 pc.	1 pc.	8 pcs.	7 pcs.
Shape				

Name	(5) Installation pattern paper	(6) Screw (M4)	(7) Washer clamp	Joint insulating material
Quantity	1 sheet	4 pcs.	4 pcs.	1 each
Shape				 

Name	Sealing material			
	Quantity	1 each	1 sheet	1 pc.
Shape	(10) Large  (11) Medium-1 	(12) Medium-2 	(13) Small 	(14) 

Name	(15) Installation guide	(16) Insulation tube	Conduit mounting plate	(Miscellaneous) • Operation Manual • Installation Manual
Quantity	1 sheet	1 pc.	1 pc.	
Shape			(17) 	

- Screws for fixing the panel are attached to the decoration panel.

1-2 OPTIONAL ACCESSORIES

- This indoor unit separately requires a decoration panel and a remote controller.
- Confirm if a decoration panel shown in the Table 1 is prepared and meets your model.
(Refer to the installation manual attached to the decoration panel for how to install.)

Table 1

Unit model	Optional decoration panel
FXFQ07 · 09 · 12 · 15 · 18 · 24 · 30 · 36 · 48TVJU	BYCQ125BGW1, BYCQ125B-W1 Color : Fresh white

- There are 2 kinds of remote controller; wired type and wireless type.
Install the remote controller to the place where the customer has given consent.
Refer to the catalog for the applicable model.
(Refer to the installation manual attached to the remote controller for how to install.)

CARRY OUT THE WORK GIVING CAUTION TO THE FOLLOWING ITEMS AND AFTER THE WORK IS COMPLETED CHECK THESE AGAIN.

1. Items to be checked after the installation work is completed

Items to be checked	In case of defective	✓
Are the indoor and outdoor units rigidly fixed?	Drop · vibration · noise	
Are the installation works of the outdoor and indoor units completed?	Does not operate · burnout	
Have you carried out a leakage test with the test pressure specified in the outdoor unit installation manual?	Does not cool / Does not heat	
Is the insulation of refrigerant piping and drain piping completely carried out?	Water leakage	
Does the drain flow out smoothly?	Water leakage	
Is the power supply voltage identical to that stated in the manufacturer's label on the air conditioner?	Does not operate · burnout	
Are you sure that there is no wrong wiring or piping or no loose wiring?	Does not operate · burnout	
Is grounding completed?	Danger in case of leakage	
Are the sizes of electric wiring according to the specification?	Does not operate · burnout	
Are any of air outlets or inlets of the indoor and outdoor units blocked with obstacles? If so, it could cause the capacity to drop due to fan-speed drop or malfunction of equipment.	Does not cool / Does not heat	
Have you recorded the refrigerant piping length and the refrigerant charge added?	Refrigerant charge amount is not clear	

Make sure to recheck the items of **SAFETY CONSIDERATIONS**.

2. Items to be checked at delivery

Items to be checked	✓
Have you carried out field setting? (if necessary)	
Are the control box lid, the air filter, and the suction grille attached?	
Does the cool air discharge during the cooling operation and the warm air discharge during the heating operation? Have you checked to make sure the indoor unit does not make unpleasant air-discharge sounds?	
Have you explained how to operate the air conditioner while showing the operation manual to the customer?	
Have you explained to the customer the description of cooling, heating, program dry and automatic (cooling/heating) while showing the operation manual to the customer?	
If you set the fan speed at thermostat OFF, did you explain the set fan speed to the customer?	
Have you handed the operation manual and the installation manual to the customer?	

Points of the operation explanation

In addition to the general usage, since the items in the operation manual with the **⚠ WARNING** and **⚠ CAUTION** marks are likely to result in human bodily injuries and property damages, it is necessary not only to explain these items to the customer but also to have the customer read them.

2. SELECTION OF INSTALLATION LOCATION

Hold the hangers at 4 locations to move the indoor unit when unpacking or after unpacked, and do not apply force to the piping (refrigerant and drain) and resin parts. If the temperature and humidity in the ceiling is likely to exceed 86°F (30°C), RH80%, use the optional kit for coping with high temperature and humidity, or additionally stick the insulation to the indoor unit. Use the insulation such as glass wool or polyethylene that has thickness of 3/8 in (10 mm), or more. However, keep the insulated outside dimension smaller than the ceiling opening so that the unit may go through the opening at installation.

The direction of air discharge for this product can be selected. Sealing material of air discharge outlet is available option for 4-way with sealed corners, and 3-way.

- (1) Select the installation location that meets the following conditions and get approval of the customer.
- Where the cool and warm air spreads evenly in the room.
 - Where there are no obstacles in the air passage.
 - Where drainage can be ensured.
 - Where the ceiling surface is not inclined.
 - Where there is sufficient strength to withstand the mass of the indoor unit. If the strength is insufficient, the indoor unit may vibrate and get in contact with the ceiling and generate noise.
 - Where a space sufficient for installation and service can be ensured. (Refer to Fig. 1)
 - Where the piping length between the indoor and the outdoor units is ensured within the allowable length. Refer to the installation manual attached to the outdoor unit.
 - Where there is no risk of flammable gas leak.

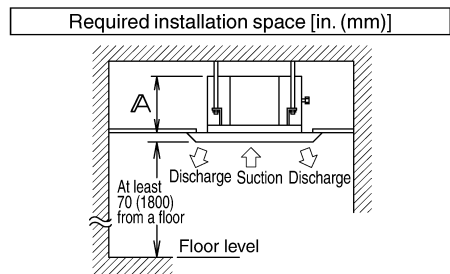

Fig. 1

MODEL NAME (FXFQ-TVJU)	A [in. (mm)]	
	BYCQ125B-W1	BYCQ125BGW1
07 · 09 · 12 · 15 · 18 · 24	10 (256)	13-1/4 (336)
30 · 36 · 48	11-3/4 (298)	14-7/8 (378)

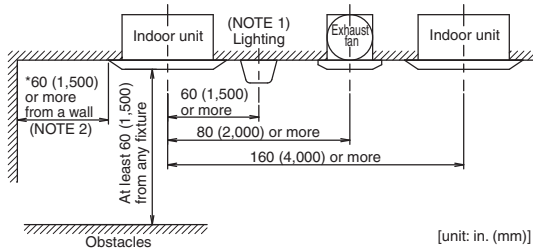

Fig. 2

CAUTION

- Any vents, light fixtures, or other appliances which may disturb the airflow might soil the ceiling if too close, so follow Fig. 2 when installing.

Note)

- This restriction applies to the exposed type lighting, but does not apply to the recessed type, which does not protrude below the ceiling line.
- The clearance from the wall (indicated with *) must be 20 in. (500 mm) or more if the air outlet is closed or the horizontal blade is set to Airflow block and, if the corners (left and right corners of the target air outlet) are also closed by 8 in. (200 mm) or more. For how to set the airflow direction (including Airflow block) with the horizontal blade, refer to **Individual Airflow Direction** in the operation manual attached to the remote controller.

- Install the indoor and outdoor units, power supply wiring, remote controller wiring and transmission wiring at least 40 in. (1 m) away from televisions or radios to prevent image interference or noise. (Depending on the radio waves, a distance of 40 in. (1 m) may not be sufficient to eliminate the noise.)
- Install the indoor unit as far as possible from fluorescent lamps. If a wireless remote controller kit is installed, the transmission distance may be shorter in a room where an electronic lighting type (inverter or rapid start type) fluorescent lamp is installed.
- Localized temperature difference from the room temperature, if too large, can affect how the infrared floor sensor judges. (This may occur, for example, in an area where floor heating/high-temperature heat generating equipment is installed.)
- Each sensor has been set so that the center of the sensing area is located in the center of the product 32 in. (800 mm) above the floor (in case of the infrared presence sensor) or 0 in. (0 mm) above the floor (in case of the infrared floor sensor) when the ceiling height is approximately 8-3/4 ft. (2.7 m).

(2) Ceiling height

- This indoor unit can be installed in a space of which ceiling height is up to 11-1/2 ft. (3.5 m) (Type 30 · 36 · 48: 13-3/4 ft. (4.2 m))
- However, if the ceiling height exceeds 8-3/4 ft. (2.7 m) (Type 30 · 36 · 48: 10-1/2 ft. (3.2 m)), it is necessary to set from the remote controller on site. Refer to the section **9. FIELD SETTING AND TEST OPERATION**.

(3) Direction of the air discharge

- Select the number of directions of the optimum air discharge for the shape or the position of the room.
- The number of directions of the air discharge can be changed by installing a sealing material.
- When installing a sealing material, the field setting from the remote controller is required. For details, refer to the operation manual attached to the sealing materials. (It is set to the setting position number **01** (Standard · All round outlet) when shipped from the factory.)
- To use the optional sealing material kit to change the setting of air discharge direction (4-way blow type (with corners sealed)/3-way blow type), refer to the installation manual attached to it.

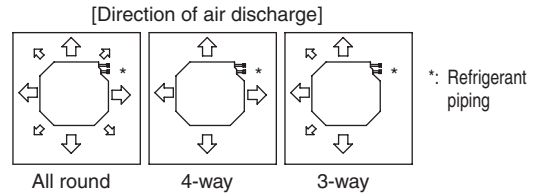

Fig. 3

(4) Use hanging bolts for installation.

Investigate if the installation place can withstand the mass of the indoor unit and, if necessary, hang the indoor unit with bolts after it is reinforced by beams etc. (Refer to the installation pattern paper (5) for the mounting pitch.)

(5) Infrared presence/floor sensor's sensing area

The sensing area is as shown in the figure below.

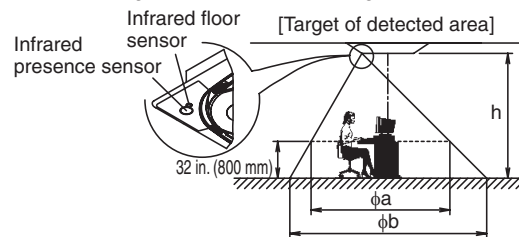

Indoor unit installation height h [ft. (m)]	8-3/4 (2.7)	11-1/2 (3.5)	13 (4.0)
Infrared presence sensor φa [ft. (m)]	Approx. 28 (8.5)	Approx. 37-1/2 (11.5)	Approx. 44-1/2 (13.5)
Infrared floor sensor φb [ft. (m)]	Approx. 36 (11)	Approx. 46 (14)	Approx. 52-1/2 (16)

3. PREPARATION BEFORE INSTALLATION

(1) Check the relation of location between the ceiling opening and the indoor unit hanging bolts.

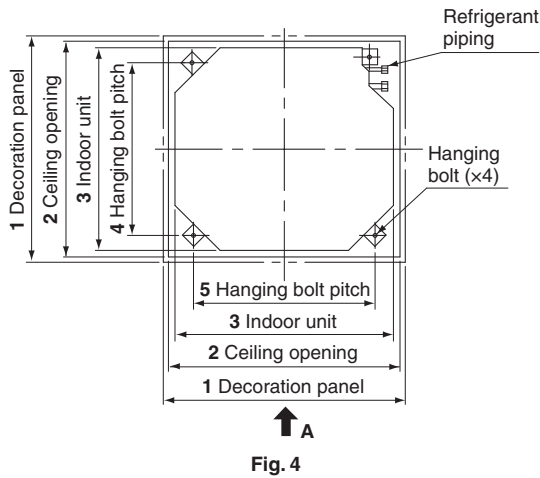

	[unit: in. (mm)]
1	37-3/8 (950)
2	33-7/8 – 35-7/8 (860 – 910)
3	33-1/16 (840)
4	30-3/4 (780)
5	28 (710)

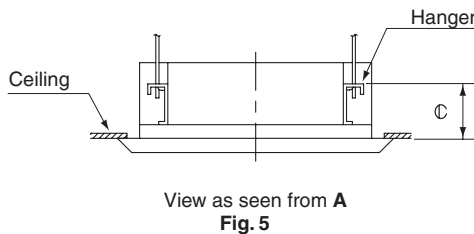

Decoration Panel	BYCQ125B-W1	BYCQ125BGW1
⊕ in. (mm)	4-15/16 – 5-1/8 (125 – 130)	8-1/16 – 8-1/4 (205 – 210)

CAUTION

Reduce the distance between the unit and ceiling to 1-3/8 in. (35 mm) or below in order to maintain an overlapping panel margin 13/16 in. (20 mm) for the opening on the ceiling. If the distance exceeds 1-3/8 in. (35 mm), attach ceiling material to the part marked or replace the ceiling. (Refer to Fig. 6)

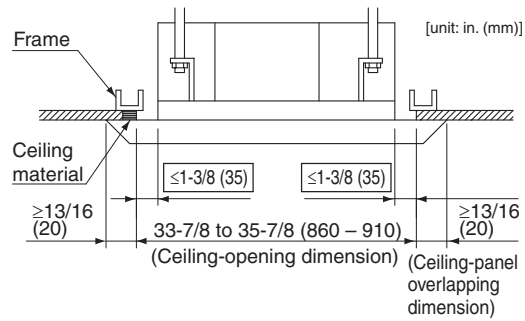

Fig. 6

(2) Make the ceiling opening required for installation.

- Use the installation pattern paper (5) matched to the ceiling opening dimension.
- Make the ceiling opening required for installation at the installation location and carry out refrigerant/drain piping, power supply wiring, remote controller wiring (not needed in case of wireless remote controller) and wiring between the indoor and outdoor units. (Refer to each section 5. REFRIGERANT PIPING WORK, 6. DRAIN PIPING WORK and 7. ELECTRIC WIRING WORK)
- After making the opening, sometimes it is necessary to reinforce the ceiling framework to maintain a level ceiling and prevent it from vibrating. For details, consult with the builder and interior designer.

(3) Install the hanging bolts.

- Use M8 or M10 bolts for hanging the indoor unit.
- Use hole-in-anchors for the existing bolts and embedded inserts or foundation bolts for new bolts, and fix the indoor unit firmly to the building so that it may withstand the mass of the unit. In addition, adjust clearance (2 – 4 in. (50 – 100 mm)) from the ceiling in advance.

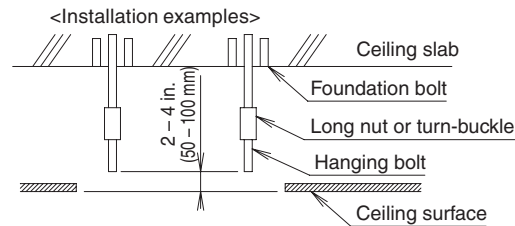

Note) The above shown parts are all field supply.

4. INSTALLATION OF INDOOR UNIT

<<It is easy to attach the optional parts (except for decoration panel) before installing the indoor unit. Refer to also the installation manual attached to the optional parts.>>

For installation, use the attached installation parts and specified parts.

[Install the indoor unit in the order of steps (1), (2), (3), (4), (5), and (6) in case of a newly built ceiling, or in the order of steps (1), (3), (4), and (5) in case of an existing ceiling.]

- (1) Install the indoor unit temporarily.
- Fix the hanger to the hanging bolt. Make sure to securely fix the hanger with the nut and the washer for hanger (3) from the upper and lower side. (Refer to Fig. 7)
If the washer clamp (7) is used, the upper side washer for hanger (3) may be protected from falling off. (Refer to Fig. 8)

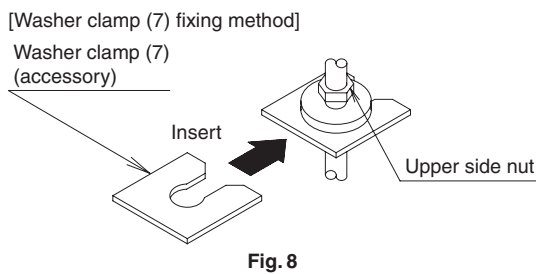
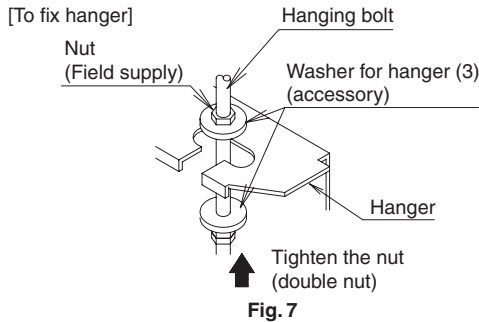

- (2)
- The installation pattern paper (5) is matched to the ceiling opening dimension. For the height of ceiling lower surface from the floor level, confirm with the builder of ceiling.
 - The center of the ceiling opening is shown in the installation pattern paper (5). The center of the indoor unit is indicated as triangle marks on the sides and bottom of the unit and those on the installation pattern paper (5).
 - Put the installation pattern paper (5) to the indoor unit with four screws (6). At this time, put the installation pattern paper (5) to the indoor unit with the triangle marks on the indoor unit and those on the installation pattern paper (5) aligned.

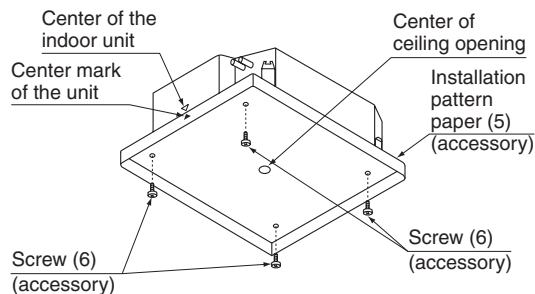

< Installation work after the ceiling work is finished >

- (3) Adjust so that the unit will be properly positioned. (Refer to 3. PREPARATION BEFORE INSTALLATION – (1))
- Using the Installation guide (15) allows you to check the positions from the underside of the unit to the lower ceiling surface.

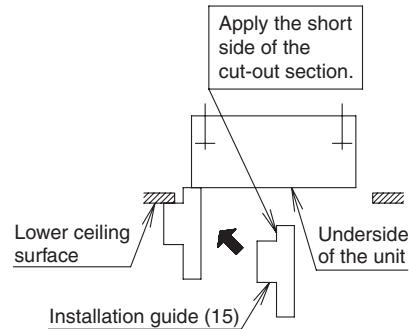

- (4) Check the level of the unit. (Refer to Fig. 9)
- (5) Remove the washer clamp (7) used for preventing the washer for hanger (3) from dropping and tighten the upper side nut.
- (6) Remove the installation pattern paper (5).

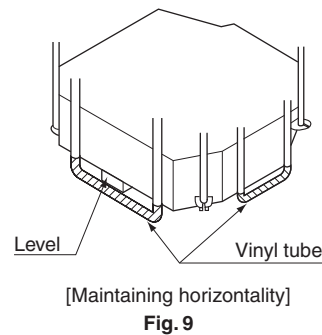

CAUTION

- Install the indoor unit leveled.**
If the indoor unit is inclined and the drain piping side gets high, it may cause malfunction of a float switch and results in water leakage.
- Attach nuts on the upper and lower side of hanger.**
If there is no upper nut and the lower nut is over-tightened, the hanger and the top plate malfunction and create unwanted noise.
- Do not insert materials other than those specified into the clearance between the hanger and the washer for hanger (3).**
Unless the washers are properly attached, the hanging bolts may come off from the hanger.

WARNING

- The indoor unit must be securely installed on a place that can withstand the mass.**
If the strength is insufficient, the indoor unit may fall down and cause injuries.

5. REFRIGERANT PIPING WORK

- For the outdoor unit refrigerant piping, refer to the installation manual attached to the outdoor unit.
- Carry out insulation of both gas and liquid refrigerant piping securely. If not insulated, it may cause water leakage. For gas piping, use insulation material of which heat resistant temperature is not less than 250°F (120 °C). For use under high humidity, strengthen the insulation material for refrigerant piping. If not strengthened, the surface of insulation material may sweat.
- Before installation work, make sure that the refrigerant is R410A or operation will malfunction.

! CAUTION

This air conditioner is a dedicated model for new refrigerant R410A. Make sure to meet the requirements shown below and carry out installation work.

- Use dedicated piping cutters and flaring tools for R410A.
- When making a flare connection, coat the flared inner surface only with ether oil or ester oil.
- Use only the flare nuts attached to the air conditioner. If other flare nuts are used, it may cause refrigerant leakage.
- To prevent contamination or moisture from getting into the piping, take measures such as pinching or taping the pipings.

Do not mix substance other than the specified refrigerant such as air into the refrigeration circuit. If the refrigerant leaks during the work, ventilate the room.

- The refrigerant is pre-charged in the outdoor unit.
- When connecting the pipings to the air conditioner, make sure to use a spanner and a torque wrench as shown in Fig. 10.
- For the dimension of flared part and the tightening torque, refer to the Table 2.
- When making a flare connection, coat the flared inner surface only with ether oil or ester oil.

(Refer to Fig. 11)

Then, turn the flare nut 3 to 4 times with your hand and screw in the nut.

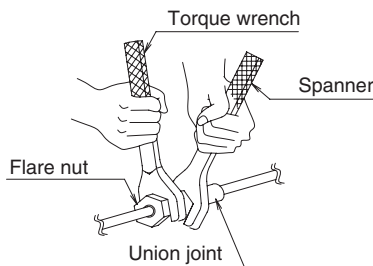

Fig. 10

Coat the flared inner surface only with ether oil or ester oil

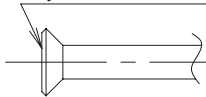

Fig. 11

Table 2

Piping size [in. (mm)]	Tightening torque [lbf-ft. (N-m)]	Dimension for processing flare A [in. (mm)]	Flare shape
φ 1/4 (6.4)	10.4 – 12.7 (15.7±1.5)	0.342 – 0.358 (8.9±0.2)	
φ 3/8 (9.5)	24.1 – 29.4 (36.3±3.6)	0.504 – 0.520 (13.0±0.2)	
φ 1/2 (12.7)	36.5 – 44.5 (54.9±5.4)	0.638 – 0.654 (16.4±0.2)	
φ 5/8 (15.9)	45.6 – 55.6 (68.6±6.8)	0.760 – 0.776 (19.5±0.2)	

! CAUTION

Do not let oil adhere to the screw fixing part of resin parts.

If oil adheres, it may weaken the strength of screwed part.

Do not tighten flare nuts too much.

If a flare nut cracks, the refrigerant may leak.

- If there is no torque wrench, use Table 3 as a rule of thumb. When tightening a flare nut with a spanner harder and harder, there is a point where the tightening torque suddenly increases. From that position, tighten the nut additionally the angle shown in Table 3. After the work is finished, check securely that there is no gas leak. If the nut is not tightened as instructed, it may cause slow refrigerant leak and result in malfunction (such as does not cool or heat).

Table 3

Piping size [in. (mm)]	Tightening angle	Recommended arm length of tool used
φ 1/4 (6.4)	60° – 90°	Approx. 6 in. (150 mm)
φ 3/8 (9.5)	60° – 90°	Approx. 8 in. (200 mm)
φ 1/2 (12.7)	30° – 60°	Approx. 10 in. (250 mm)
φ 5/8 (15.9)	30° – 60°	Approx. 12 in. (300 mm)

! CAUTION

Insulation of field piping must be carried out up to the connection inside the casing.

If the piping is exposed to the atmosphere, it may cause sweating, burn due to touching the piping, electric shocks or a fire due to the wiring touching the piping.

- After leak test, referring to Fig. 12, insulate both the gas and liquid piping connection with the attached joint insulating material (8) and (9) to prevent the pipings from getting exposed. Then, tighten the both ends of insulating material with the clamp (4).
- Wrap the sealing material (Medium-1, 2) (11) (12) around the joint insulating material (8) and (9) (flare nut section), both the gas and liquid piping.
- Make sure to bring the seam of joint insulating material (8) and (9) to the top.

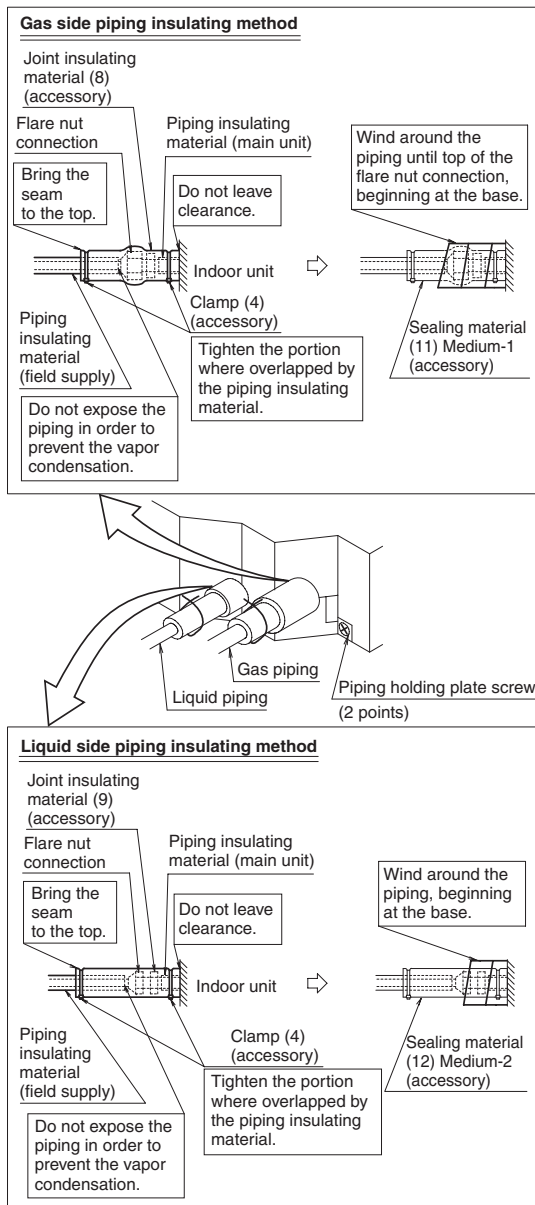

Fig. 12

- Before brazing refrigerant piping, have nitrogen flow through the refrigerant piping and substitute air with nitrogen (NOTE 1) (Refer to Fig. 13). Then, carry out brazing (NOTE 2). After all the brazing works are finished, carry out flare connection with the indoor unit. (Refer to Fig. 12)

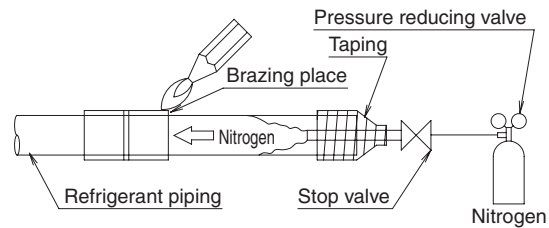

Fig. 13

NOTE

1. The proper pressure for having nitrogen flow through the piping is approximately 2.9 psi (0.02 MPa), a pressure that makes one feel like breeze and can be obtained through a pressure reducing valve.
2. Do not use flux when brazing refrigerant piping. Use phosphor copper brazing filler metal (BCuP-2: JIS Z 3264/B-Cu93P-710/795: ISO 3677) that does not require flux. (If chlorinated flux is used, the piping will be corroded and, in addition if fluorine is contained, the refrigerant oil will be deteriorated and the refrigerant circuit will be affected badly.)
3. When carrying out leakage test of refrigerant piping and the indoor unit after the installation of indoor unit is finished, confirm the connecting outdoor unit installation manual for test pressure. Refer to the outdoor unit installation manual or technical document for refrigerant piping.
4. In case of refrigerant shortage due to forgetting additional refrigerant charge etc., it will result in malfunctions such as not cooling or heating. Refer to the outdoor unit installation manual or technical document for refrigerant piping.

CAUTION**Do not use antioxidant when brazing piping.**

It may result in malfunction of components and clogging of piping due to residue.

6. DRAIN PIPING WORK**(1) Carry out drain piping.**

Carry out drain piping so that drainage can be ensured.

- Select the piping diameter equal to or larger than (except for riser) that of the connection piping (PVC pipe piping, nominal diameter 1 in. (25 mm), outside diameter 1-1/4 in. (32 mm)).
- Install the drain piping as short as possible with downward inclination of 1/100 or more where air cannot stagnate. (Refer to Fig. 14) Bubbling sound may occur.

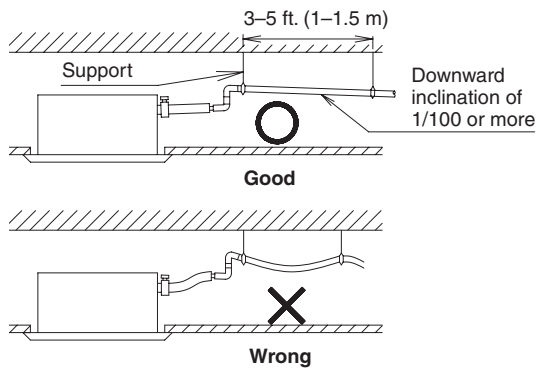

Fig. 14

CAUTION

If drainage stagnates in the drain piping, the piping may get clogged.

- If sufficient downward inclination cannot be ensured, carry out upward drain piping.
- Install supports at a distance of 3–5 ft. (1–1.5 m) so that the piping may not deflect. (Refer to Fig. 14)
- Make sure to use the attached drain hose (1) and the metal clamp (2).

Insert the drain hose (1) into the drain socket up to the point where the socket diameter becomes larger. Put the metal clamp (2) to the taped hose end and tighten the metal clamp (2) with torque 1.35 ± 0.15 N·m (135 ± 15 N·cm).

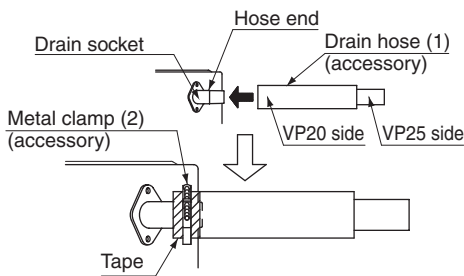
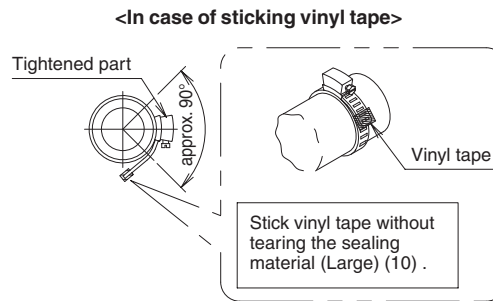

Fig. 15

CAUTION

- Do not tighten the metal clamp (2) with the torque more than the specified value. The drain hose (1), the socket or the metal clamp (2) may be damaged.
- Wrap the vinyl tape around the end of the metal clamp (2) so that the sealing material (Large) (10) to be used at the next process may not be damaged with the clamp end or bend the tip of the metal clamp (2) inward as shown. (Refer to Fig. 16)



<In case of bending the tip>

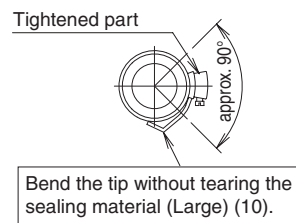
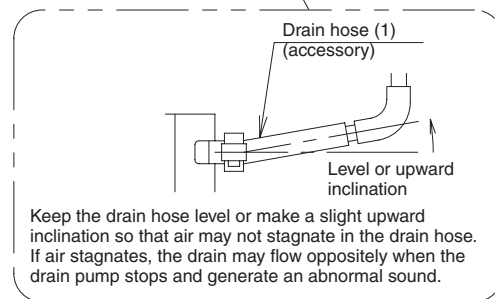
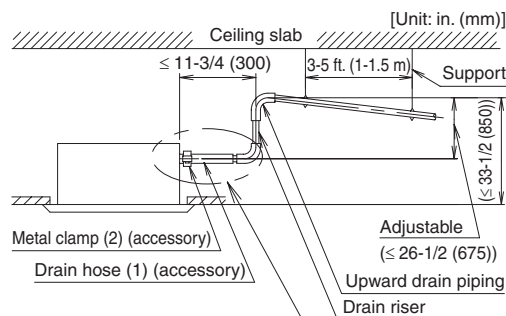

Fig. 16

< Caution to be taken when carrying out upward drain piping (Refer to Fig. 17) >

- The maximum height of the drain riser is 26-1/2 in. (675 mm) Since the drain pump mounted on this indoor unit is a high head type, from the characteristic point of view, the higher the drain riser the lower the draining noise. Therefore, the drain riser of 11-3/4 in. (300 mm) or higher is recommended.
- For upward drain piping, keep the horizontal piping distance of 11-3/4 in. (300 mm) or less between the drain socket root to the drain riser.



Keep the drain hose level or make a slight upward inclination so that air may not stagnate in the drain hose. If air stagnates, the drain may flow oppositely when the drain pump stops and generate an abnormal sound.

Fig. 17

CAUTION

- Do not apply excessive force to the attached drain hose (1) by bending or twisting it. This could cause water leakage.
- In case of centralized drain piping, carry out piping work according to the procedure shown in the following Fig. 18.

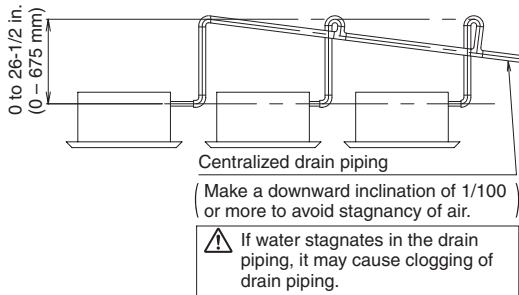

Fig. 18

- Select a size for the centralized drain piping that meets the capacity of indoor units to be connected. Refer to the technical document.
- When installing the new indoor unit, use the attached new drain hose (1) and the metal clamp (2). If an old drain hose or a metal clamp is used, it may cause water leakage.

(2) After piping is finished, check if the drain flows smoothly.

[When the electric wiring work is finished]

- Gradually pour 1/4 gal. (1 L) of water from the air outlet on the left side of the drain socket into the drain pan using caution to avoid splashing water on the electric components such as the drain pump. Confirm drainage by operating the indoor unit under cooling mode according to 9. FIELD SETTING AND TEST OPERATION. (Refer to Fig. 19)

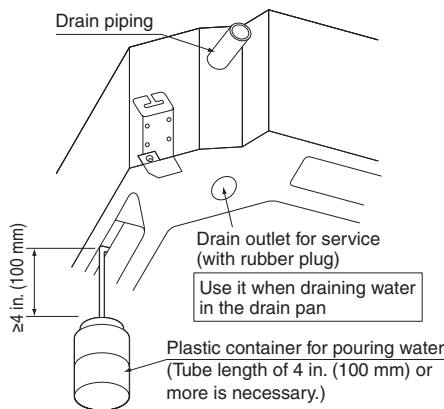

[Method of adding water]

Fig. 19

- After checking the drainage of water, refer to Fig. 20 and attach the sealing material (14) to perform the thermal insulation of the drain socket.

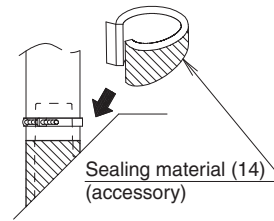

Fig. 20

[When the electric wiring work is not finished]

- The electric wiring works (including ground) must be carried out by a qualified electrician.
- If a qualified person is not present, after the electric wiring work is finished, check the drainage according to the method specified in [When the electric wiring work is finished].

1. Open the control box lid and connect the single phase 208 - 230 V power supply to the terminal (L₁, L₂) on the terminal block (X2M). Connect the ground wiring to the ground terminal. (Refer to Fig. 21)

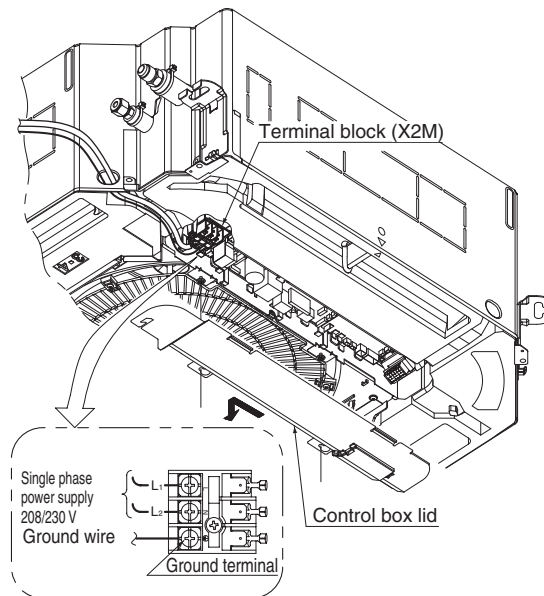

Fig. 21

2. Make sure the control box lid is closed before turning on the power supply.
 - Throughout the whole process, carry out the work using caution with wiring around the control box so that the connectors not come off.
3. Gradually pour 1/4 gal. (1 L) of water from the air outlet on the left side of the drain socket into the drain pan using caution to avoid splashing water on the electric components such as the drain pump. (Refer to Fig. 19)

4. When the power supply is turned on, the drain pump should operate. Drainage can be checked at the transparent part of the drain socket.
(The drain pump will automatically stop after 10 minutes.)
After checking the drainage of water, refer to **Fig. 20** and attach the sealing material (14) to perform the thermal insulation of the drain socket.
 - Do not connect the drain piping directly to the sewage that gives off ammonia odor.
The ammonia in the sewage may go through the drain piping and corrode the heat exchanger of the indoor unit.
 - Do not apply external force to the float switch or it could cause malfunction.
5. Turn off the power supply after checking drainage, and remove the power supply wiring.
6. Attach the control box lid as before.
 - Do not touch the electronic parts other than the terminal block (X2M).

(3) Sweating may occur and result in water leakage. Therefore, make sure to insulate the indoor drain piping and socket locations.

After drainage is checked, put the attached sealing material (14) referring to **Fig. 20**, and insulate the drain hose (1) and the metal clamp (2) with the attached sealing material (Large) (10) referring to **Fig. 22**.

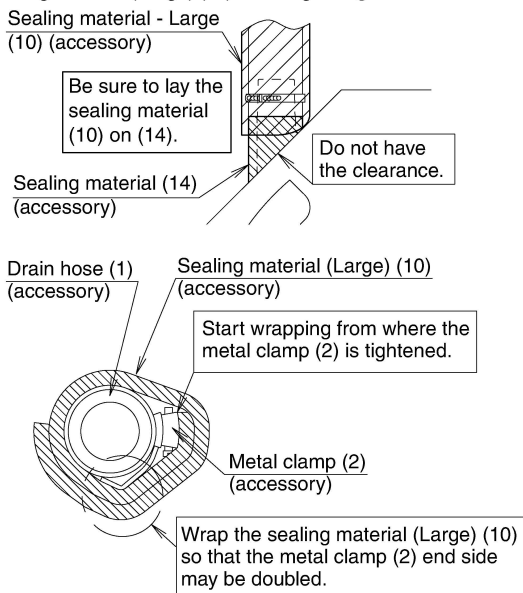

Fig. 22

7. ELECTRIC WIRING WORK

7-1 GENERAL INSTRUCTIONS

- Make sure that all electric wiring work is carried out by qualified personnel according to the applicable legislation and this installation manual, using a separate dedicated circuit.
Insufficient capacity of the power supply circuit or improper electrical construction may lead to electric shocks or a fire.
- Make sure to install a ground fault circuit interrupter. Failure to do so may cause electrical shocks and a fire.
- Do not turn on the power supply (branch switch, branch overcurrent circuit breaker) until all the works are finished.
- Multiple number of indoor units are connected to one outdoor unit. Name each indoor unit as A-unit, B-unit and the like. When these indoor units are wired to the outdoor unit and the Branch Selector, always wiring the indoor unit to the terminal indicated with the same symbol on the terminal block. If the wiring and the piping are connected to the different indoor units and operated, it will result in malfunction.
- Make sure to ground the air conditioner.
Grounding resistance should be according to applicable legislation.
- Do not connect the ground wiring to gas or water pipings, lightning conductor or telephone ground wiring.
 - Gas pipingIgnition or explosion may occur if the gas leaks.
 - Water pipingHard vinyl tubes are not effective ground.
 - Lightning conductor or telephone ground wiring..... Electric potential may rise abnormally if struck by a lightning bolt.
- For electric wiring work, refer to also the WIRING DIAGRAM attached to the control box lid.
- Carry out wiring between the outdoor units, indoor units and the remote controllers according to the wiring diagram.
- Carry out installation and wiring of the remote controller according to the installation manual attached to the remote controller.
- Do not touch the Printed Circuit Board assembly. It may cause malfunction.

7-2 ELECTRICAL CHARACTERISTICS

Units				Power supply		Fan motor	
Model	Hz	Volts	Voltage range	MCA	MFA	kW	FLA
FXFQ07TVJU	60	208/230	Max. 253 Min. 198	0.3	15	0.048	0.2
FXFQ09TVJU				0.3	15	0.048	0.2
FXFQ12TVJU				0.3	15	0.048	0.2
FXFQ15TVJU				0.4	15	0.048	0.3
FXFQ18TVJU				0.6	15	0.048	0.5
FXFQ24TVJU				0.7	15	0.048	0.5
FXFQ30TVJU				1.3	15	0.106	1.0
FXFQ36TVJU				1.5	15	0.106	1.2
FXFQ48TVJU				1.8	15	0.106	1.4

MCA: Min. Circuit Amps (A) MFA: Max. Fuse Amps (A)
kW: Fan Motor Rated Output (kW) FLA: Full Load Amps (A)

7-3 SPECIFICATION FOR FIELD SUPPLY FUSES AND WIRING

Power supply wiring		Remote controller wiring Transmission wiring	
MOP 	Size	Wiring	Size
15A	Wiring size and length must comply with local codes.	Vinyl cord with sheath or cable (2 core)	AWG 18-16

The lengths of remote controller wiring and transmission wirings are as follows:

- (1) Remote controller wiring (indoor unit - remote controller)Max. 1,640 ft. (500 m)
- (2) Transmission wirings ... Total wiring length 6,560 ft. (2,000 m)
 - Outdoor unit - Indoor unit..... Max. 3,280 ft. (1,000 m)
 - Outdoor unit - Branch Selector.... Max. 3,280 ft. (1,000 m)
 - Branch Selector - Indoor unit... Max. 3,280 ft. (1,000 m)
 - Indoor unit - Indoor unit Max. 3,280 ft. (1,000 m)

NOTE 

- 1. Shows only in case of protected piping. Use H07RN-F in case of no protection.
- 2. Vinyl cord with sheath or cable (Insulated thickness : 0.04 in. (1 mm) or more)

7-4 WIRING CONNECTION METHOD

CAUTION FOR WIRING

- The indoor units in the same system can be connected to the power supply from one branch switch. However, selection of branch switch, branch over current circuit breaker and wiring size must be according to applicable legislation.
- For connection to the terminal block, use a ring type crimp style terminals with insulation sleeve or insulate the wirings properly.

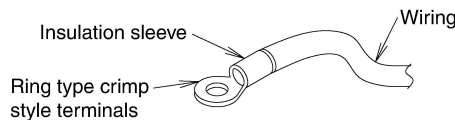

- If the above is not available, make sure to fulfill the following requirements.

Connection of 2 wirings of same size must be carried out on both sides.

Connection of 2 wirings on one side is prohibited.

Connection of wirings of different sizes is prohibited.

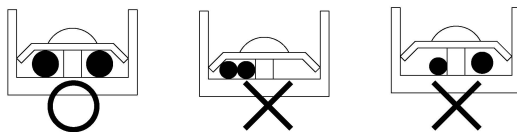

(Abnormal heating may occur if the wirings are not tightened securely.)

- Use the required wirings, connect them securely and fix these wirings securely so that external force may not apply to the terminals.
- Use a proper screw driver for tightening the terminal screws.
If an improper screw driver is used, it may damage the screw head and a proper tightening cannot be carried out.

- If a terminal is over tightened, it may be damaged. Refer to the table shown below for tightening torque of terminals.

	Tightening torque [lbf-ft. (N-m)]
Terminal block for remote controller and transmission wirings	0.65 ± 0.07 (0.88 ± 0.08)
Terminal for power supply	0.965 ± 0.095 (1.31 ± 0.13)
Ground terminal	

- Do not carry out soldering finish when stranded wirings are used.

WARNING

- When wiring, form the wirings orderly so that the control box lid can be securely fastened. If the control box lid is not in place, the wirings may float up or be sandwiched by the box and the lid and cause electric shocks or a fire.

< Power supply wiring · ground wiring · remote controller wiring · transmission wiring connecting method >

- Power supply wiring, ground wiring
Pass the power supply wire through the attached insulation tube (16) between the outlet of conduit and the power supply terminal, and bind them together with the attached clamp (4). (Refer to Fig. 23-2)

Use a pair of conduit mounting plates (17) to connect a conduit to the unit as shown Fig. 23-1. After connecting the power supply wiring to [L₁ · L₂] on the power supply terminal block (X2M) and the ground wiring to the ground terminal, clamp them near the terminal block using the attached clamp (4). (Refer to Fig. 23-2)

Remote controller wiring, transmission wiring

Pull the wiring through the wiring penetrating hole (low voltage). After connecting the remote controller wiring to [P1 · P2] and the transmission wiring to [F1 · F2] on the terminal block (X1M), clamp them near the terminal block using the attached clamp (4). (Refer to Fig. 23-2)

- After connecting the wiring, make sure to stick the sealing material (Small) (13) to the wiring penetrating hole to prevent water from entering the indoor unit. (Refer to Fig. 24)

CAUTION

- Never connect the power supply wiring to the terminal block for remote controller/transmission wiring (X1M). If may damage the total system.
- Do not connect the remote controller/transmission wiring to the wrong terminal block.

- Use a 90° elbow type of conduit with dimensions **Fig. 23-1** to prevent it from hitting the swing motor housing of decoration panel.
- Do not dispose the screw which assembles casing and resin together. The screw will be used to install conduit mounting plate. Make sure to install the conduit mounting plate first before wiring.

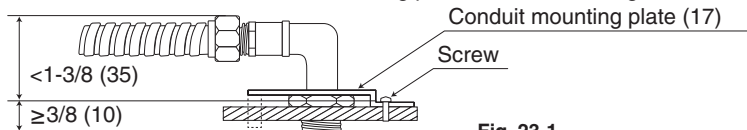

Fig. 23-1

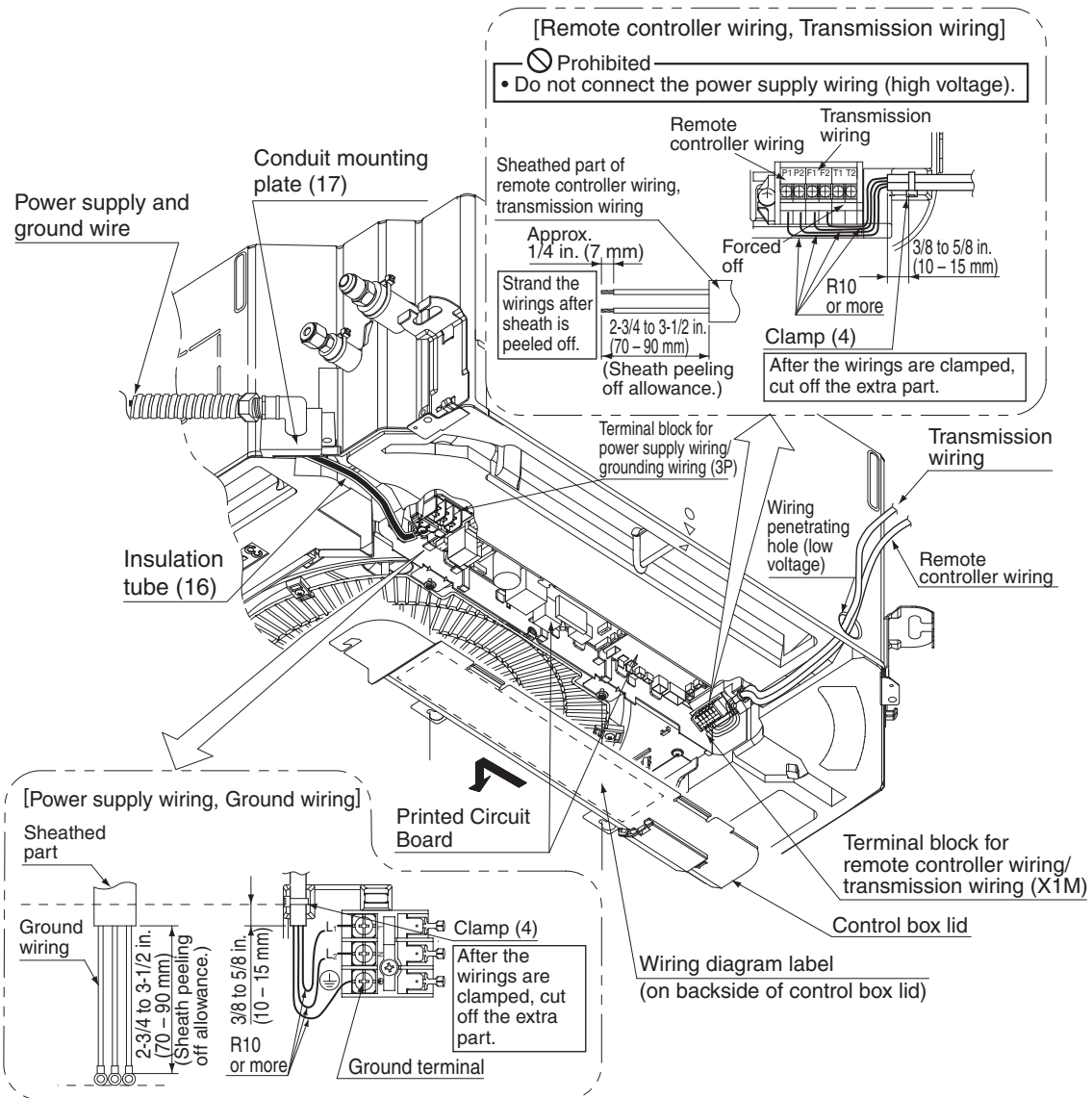

Fig. 23-2

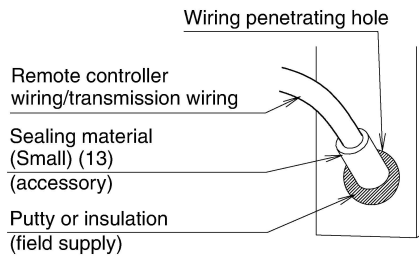

Fig. 24

<<Mending method of wiring penetrating hole>>

- After wiring connection is finished, to prevent the penetration of water, small animals and insects into the indoor unit from the outside, mend the respective covers for wiring penetrating hole for the power supply wiring/ground wiring and the remote controller wiring/transmission wiring.
- Cut the sealing material (Small) (13) into two pieces and wrap each wiring with each piece.
- Seal the clearance around the wirings with putty and insulating material (field supply).
If insects and small animals get into the indoor unit, short circuiting may occur inside the control box.
- Keep the distance of 1-15/16 in. (50 mm) or more between low voltage wiring (remote controller wiring, transmission wiring) and the high voltage wiring (power supply wiring, ground wiring) at anywhere outside the indoor unit. If both wirings are laid down together, they may be affected by outside electrical noise and cause malfunction or failure.

7-5 EXAMPLE OF WIRING

- The power wiring should be installed to meet local and national code. Fig.25 is one example of a wiring configuration.

COMPLETE SYSTEM EXAMPLE (3 systems)

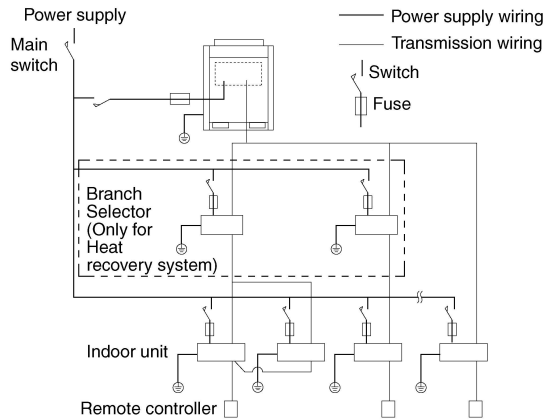

Fig. 25

1. When using 1 remote controller for 1 indoor unit. (Normal operation)

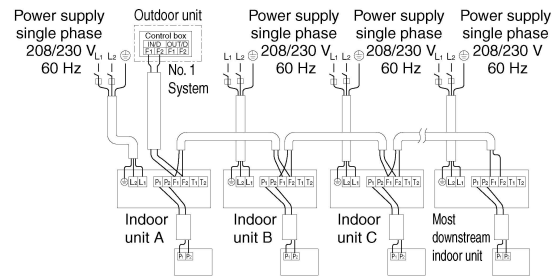

Fig. 26

2. For group control or use with 2 remote controllers

Note: It is not necessary to designate indoor unit address when using group control. The address is automatically set when power is activated.

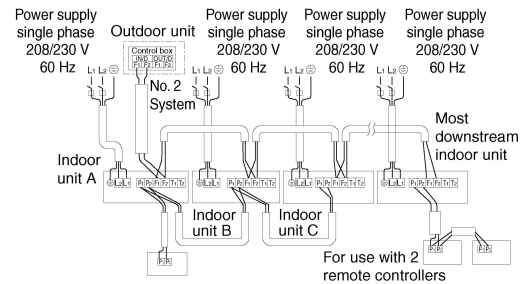

Fig. 27

3. When including Branch Selector

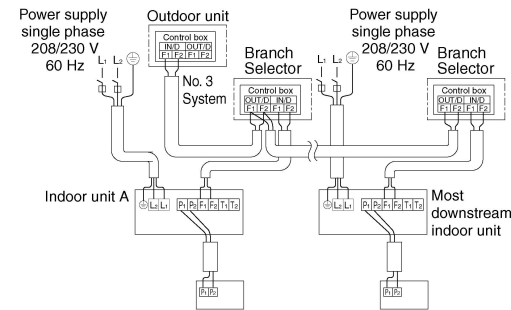

Fig. 28

[PRECAUTIONS]

1. Do not ground the equipment on gas pipes, water pipes or lightning rods, or crossground with telephones. Improper grounding could result in electric shock.

WARNING

Be sure to install an ground leakage breaker. Failure to do so may cause electric shocks and a fire.

7-6 FOR CONTROL WITH 2 REMOTE CONTROLLERS (TO CONTROL 1 INDOOR UNIT WITH 2 REMOTE CONTROLLERS)

- For control with 2 remote controllers, set one remote controller as Main and the other remote controller as Sub.
- < Changeover method from Main to Sub and vice versa >**
Refer to the installation manual attached to the remote controller.

< Wiring method >

- Remove the control box lid.
- Carry out additional wiring from the remote controller 2 (Sub) to the terminals (P1, P2) for remote controller wiring on the terminal block (X1M) in the control box.

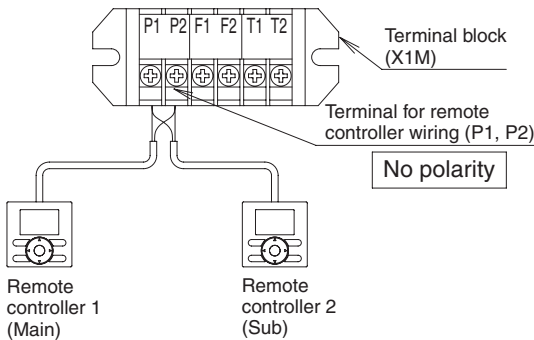

< Caution >

- When using the group control and the 2 remote controllers control at the same time, connect the remote controller 2 (Sub) to the indoor unit at the end of the crossover wiring (the largest No.). (Refer to Fig. 29)

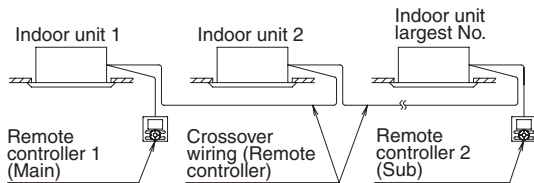

Fig. 29

7-7 FOR CENTRALIZED CONTROL

- When centralized equipment (such as centralized controller) is used for control, it is required to set the group No. on the remote controller.
- For details, refer to the manuals attached to the centralized equipment.
- Connect the centralized equipment to the indoor unit connected to the remote controller.

7-8 FOR REMOTE CONTROL (FORCE OFF OR ON / OFF OPERATION)

(1) Wiring method and specification

- Remote control is available by connecting the external input to the terminal T1 and T2 on the terminal block for remote controller and transmission wiring (X1M).

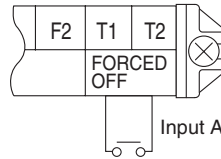

Wiring specification	Sheathed vinyl cord or 2 core cable
Gauge	AWG18-16 (0.75 - 1.25 mm ²)
Wiring length	Max. 328 ft. (100 m)
External contact spec	Contact that can make and break the min. load of 15 V DC, 1 mA

(2) Actuation

- Input A of FORCED OFF and ON/OFF OPERATION will be as the table shown below.

	Input A = ON	Input A = OFF
In case of FORCED OFF	Remote controller prohibited	Remote controller permitted
In case of ON/OFF OPERATION	Operation	Stop

(3) How to choose FORCED OFF or ON/OFF OPERATION

- For choosing FORCED OFF or ON/OFF OPERATION, setting by remote controller is required. (Refer to 9. FIELD SETTING AND TEST OPERATION.)

8. MOUNTING DECORATION PANEL

<<If test operation is required before mounting the decoration panel, 9. FIELD SETTING AND TEST OPERATION can be carried out before 8. MOUNTING DECORATION PANEL.>>

CAUTION

In case of a wireless remote controller, unless the decoration panel is mounted, field setting and test operation cannot be carried out.

Refer to the installation manual attached to the decoration panel.

- After the decoration panel is mounted, check if no clearance exists between the panel and the unit.
- If test operation is carried out before mounting the decoration panel, check the swing blade action after the panel is mounted.

9. FIELD SETTING AND TEST OPERATION

<<Refer to also the installation manual attached to the outdoor unit.>>

— CAUTION

Before carrying out field setting, check the items mentioned in Clause 2: **1. Items to be checked after the installation work is completed** on page 3. Check if all the installation and piping works for the air conditioner are completed.

- Check if the control box lids of the air conditioner are closed.

< FIELD SETTING >

<<After turn on the power supply, carry out field setting from the remote controller according to the installation state.>>

- Carry out setting at 3 places, MODE NO., FIRST CODE NO. and SECOND CODE NO..
The settings shown by in the table indicate those when shipped from the factory.
- The method of setting procedure and operation is shown in the installation manual attached to the remote controller.
(Note) Though setting of MODE NO. is carried out as a group, if you intend to carry out individual setting by each indoor unit or confirmation after setting, carry out setting with the MODE NO. shown in the parenthesis ().
- In case of remote control, for changeover of input to FORCED OFF or to ON/OFF OPERATION.
[1] Enter into the field setting mode with the remote controller.
[2] Select MODE NO. **12**.
[3] Set the FIRST CODE NO. to **1**.
[4-1] For FORCE OFF, set the SECOND CODE NO. to **01**.
[4-2] For ON/OFF OPERATION, set the SECOND CODE NO. to **02**.
(It is set to FORCE OFF when shipped from the factory.)
- Ask your customer to keep the manual attached to the remote controller together with the operation manual.
- Do not carry out settings other than those shown in the table.

9-1 SETTING CEILING HEIGHT

- Set the SECOND CODE NO. according to the ceiling height as shown in the Table 4.

Table 4

Setting	Ceiling height [in. (m)]		MODE NO.	FIRST CODE NO.	SECOND CODE NO.
	FXFQ-TVJU				
	07 · 09 · 12 · 15 · 18 · 24 type	30 · 36 · 48 type			
Standard	≤ 8 to 3/4 (2.7 or less)	≤ 10 to 1/2 (3.2 or less)	13 (23)	0	01
High ceiling 1	8-3/4 to 10 (2.7 – 3.0)	10-1/2 to 12 (3.2 – 3.6)	13 (23)	0	02
High ceiling 2	10 to 11-1/2 (3.0 – 3.5)	12 to 13-3/4 (3.6 – 4.2)	13 (23)	0	03

9-2 SETTING AIR DISCHARGE DIRECTION

- Refer to the installation manual attached to the sealing material of air discharge outlet sold separately and engineering data book, for ceiling height settings for four-direction (part of corner closed off) and three-direction.
(The SECOND CODE NO. is factory set to **01** (all round outlet) before shipping.)

9-3 SETTING WHEN AN OPTIONAL ACCESSORY IS ATTACHED

- For setting when attaching an optional accessory, refer to the installation manual attached to the optional accessory.

9-4 WHEN USING WIRELESS REMOTE CONTROLLER

- When using a wireless remote controller, it is necessary to set the wireless remote controller address.
Refer to the installation manual attached to the wireless remote controller.

9-5 SETTING FAN SPEED DURING THERMOSTAT OFF

- Set the fan speed according to the using environment after consultation with your customer.
- When the fan speed is changed, explain the set fan speed to your customer.

Table 5

Setting		MODE NO.	FIRST CODE NO.	SECOND CODE NO.
Fan speed during cooling thermostat OFF	LL (Extra low) Setting	12 (22)	6	01
				02
Fan speed during heating thermostat OFF	LL (Extra low) Setting	12 (22)	3	01
				02

9-6 SETTING FILTER SIGN

- A message to inform the air filter cleaning time will be indicated on the remote controller.
- Set the SECOND CODE NO. shown in the Table 6 according to the amount of dust or pollution in the room.
- Though the indoor unit is equipped with the long life filter, it is necessary to periodically clean the filter to avoid clogging of the filter. Please also explain the set time to the customer.
- The periodic filter-cleaning time can be shortened depending on the environment.

Table 6

Contamination	Hours until indication	MODE NO.	FIRST CODE NO.	SECOND CODE NO.
Normal	Approx. 2,500 hrs	10 (20)	0	01
More contaminated	Approx. 1,250 hrs			02
With indication				01
	No indication*		3	02

* Use **No indication** setting when cleaning indication is not necessary such as the case of periodical cleaning being carried out.

<TEST OPERATION >

- After cleaning the indoor unit inside, carry out test operation according to installation manual attached to the outdoor unit.
- When the remote controller operation lamp flashes, it shows that something is abnormal. Check the malfunction codes on the remote controller. The relation between the malfunction codes and malfunction details is described in the operation manual attached to the outdoor unit. Particularly, if the indication is one of those shown in the Table 7, it may be an error in the electrical wiring or the power supply is disconnected. Therefore, recheck wiring.

Table 7

Remote controller indication	Details
Though the centralized control is not carried out, the lamp  turns on.	<ul style="list-style-type: none"> • The terminals (T1 · T2) for FORCED OFF on the indoor unit transmission terminal block is short circuited.
[U4] displays. [UH] displays.	<ul style="list-style-type: none"> • The power supply to the outdoor unit is not made. • The power supply work to the outdoor unit is not carried out. • The transmission wiring and the remote controller wiring and FORCED OFF wiring are connected incorrectly. • The transmission wiring is disconnected.
No indication	<ul style="list-style-type: none"> • The power supply to the indoor unit is not made. • The power supply work to the indoor unit is not carried out. • The remote controller wiring and the transmission wiring and FORCED OFF wiring are connected incorrectly. • The remote controller wiring is disconnected.

- At test operation, if the decoration panel is mounted, check the actuation of the swing blade.

 **CAUTION**

After test operation is completed, check the items mentioned in Clause 2: **2. Items to be checked at delivery** on page 3.

If the interior finish work is not completed when the test operation is finished, for protection of the air conditioner, ask the customer not to operate the air conditioner until the interior finish work is completed.

If the air conditioner is operated, the inside of the indoor units may be polluted by substances generated from the coating and adhesives used for the interior finish work and cause water splash and leakage.

 **To the operator carrying out test operation**

After test operation is completed, before delivering the air conditioner to the customer, confirm that the control box lid, the air filter and suction grille are attached.

In addition, explain the power supply status (power supply ON/OFF) to the customer.

12. Accessories

12.1 Optional Accessories (for Unit)

Option		Note	FXFQ07TVJU FXFQ09TVJU FXFQ12TVJU FXFQ15TVJU FXFQ18TVJU FXFQ24TVJU	FXFQ30TVJU FXFQ36TVJU FXFQ48TVJU	FXFQ07TVJU FXFQ09TVJU FXFQ12TVJU FXFQ15TVJU FXFQ18TVJU FXFQ24TVJU	FXFQ30TVJU FXFQ36TVJU FXFQ48TVJU
Type of decoration panel			WHEN USING SELF CLEANING DECO PANEL		WHEN USING STANDARD DECO PANEL	
Self cleaning decoration panel			BYCQ125BGW1		-	
Connection pipe (Nozzule for dust recovery)			KKHAP55B160		-	
L-shape extension pipe			KKHAP55A160		-	
Decoration panel			-		BYCQ125B-W1	
Sealing material of air discharge outlet			KDBH55K160F		KDBHQ55B140	
Panel spacer			KDBP55H160FA		KDBP55H160FA	
Fresh air intake kit	Chamber type	Without T shape pipe	-		KDDQ55B140	
		With T shape pipe	-		KDDP55B160K	
	Direct installation type	-		KDDP55X160		
Filter chamber			-		KDDFP55B160	
Replacement long life filter			-		KAFP55B160	
Replacement ultra long life filter			-		KAFP55H160H	
Replacement filter for self cleaning decoration panel			KAFP554A160		-	
Branch duct chamber			KDJP55B80	KDJP55B160	KDJP55B80	KDJP55B160

3D086933B

12.2 Optional Accessories (for Controls)

Option		Note	FXFQ07TVJU FXFQ09TVJU FXFQ12TVJU FXFQ15TVJU FXFQ18TVJU FXFQ24TVJU	FXFQ30TVJU FXFQ36TVJU FXFQ48TVJU	FXFQ07TVJU FXFQ09TVJU FXFQ12TVJU FXFQ15TVJU FXFQ18TVJU FXFQ24TVJU	FXFQ30TVJU FXFQ36TVJU FXFQ48TVJU
Remote controller	Wired type	Without sensing function	BRC1E72		BRC1E72	
		With sensing function	BRC1E52B7		BRC1E52B7	
Central remote controller			DCS302C71		DCS302C71	
Electrical box			KJB311AA		KJB311AA	
Unified ON/OFF controller			DCS301C71		DCS301C71	
Electrical box			KJB212AA		KJB212AA	
Schedule timer			DST301BA61		DCS301BA61	
intelligent Touch controller			DCS601C71		DCS601C71	
Wiring adaptor printed circuit board		1	KRP1C75		KRP1C75	
Group control adaptor printed circuit board		1	KRP4A74		KRP4A74	
External control adaptor for outdoor unit		1	DTA104A62		DTA104A62	
DIII-NET expander adaptor			DTA109A51		DTA109A51	
Remote sensor			KRCS01-4B		KRCS01-4B	
Installation box for adaptor printed circuit board		2,3	KRP1J98		KRP1H98	
Adaptor for multi tenant		1	DTA114A61		DTA114A61	

3D086933B

- Notes:**
1. Installation box for adaptor printed circuit board (KRP1J98/KRP1H98) is necessary.
 2. Up to two adaptors can be fixed for each installation box.
 3. Only one installation box can be installed to each indoor unit.

13. Detail of Optional Accessories

13.1 BYCQ125BGW1 — Self Cleaning Decoration Panel

DAIKIN

BYCQ125BGW1

Self cleaning decoration panel

Installation manual

1. Safety Considerations

Please read these "Safety Considerations" carefully before installing air conditioning equipment and be sure to install it correctly. After completing installation, conduct a trial operation to check for faults and explain to the customer how to operate the air conditioner and take care of it with the aid of the operation manual. Ask the customer to store the installation manual along with the operation manual for future reference.

This air conditioner comes under the term "appliances not accessible to the general public".

Meaning of WARNING and CAUTION notices.

⚠ WARNING Failure to follow these instructions properly may result in personal injury or loss of life.

⚠ CAUTION Failure to observe these instructions properly may result in property damage or personal injury, which may be serious depending on the circumstances.

⚠ WARNING

- Ask your dealer or qualified personnel to carry out installation work.
Do not attempt to install the air conditioner yourself. Improper installation may result in water leakage, electric shocks or fire.
- Perform installation work in accordance with the instructions in this installation manual. Do not modify the product.
Improper installation may result in water leakage, electric shocks, or fire.
- Be sure to use only the specified accessories and parts for installation work.
Failure to use the specified parts may result in the unit falling, water leakage, electric shocks or fire.
- Make sure that specified wires are used and that there is no strain on the terminal connections or wires.
Improper connections or securing of wires may result in abnormal heat radiation or fire.
- Be sure to switch off the unit before touching any electrical parts.
- Arrange the lead wires of the provided harness so that the control box cover of the indoor unit will not rise, and attach the cover securely.
Heat radiation, electric shocks, or fire may result if the control box cover is not attached properly.
- Tear up and dispose of the plastic bag.
Children playing with the plastic bag may be suffocated.

⚠ CAUTION

- Install the indoor and outdoor units, power cord, remote controller wiring, and transmission wiring at least 1 m away from TV or radio sets. This is for the prevention of TV and radio interference. (Depending on the incoming signal strength, a distance of 1 m may not be sufficient to eliminate noise.)
- Pay the utmost attention to the transportation of the product. Hold the handles on the package to carry the product. Do not carry the package with the polypropylene band on the package held, which will be dangerous because the polypropylene band may be deformed.
- Do not touch the fin of the heat exchanger. Touching the fin improperly may result in injury.
- Do not turn the product power off immediately after the operation of the product comes to a stop. Always wait for at least 5 minutes before turning the product power off. Otherwise, water leakage and malfunctions may result.
- Do not install the air conditioner in the following locations:
 1. Where there is a high concentration of mineral oil spray or vapour (e.g. a kitchen).
Plastic parts will deteriorate, parts may fall off and water leakage could result.
 2. Where corrosive gas, such as sulphurous acid gas, is produced.
Corroding of copper pipes or soldered parts may result in refrigerant leakage.
 3. Near machinery emitting electromagnetic radiation.
Electromagnetic radiation may disturb the operation of the control system and result in a malfunction of the unit.
 4. Where flammable gas may leak, where there is carbon fibre or ignitable dust suspensions in the air, or where volatile flammables such as paint thinner or gasoline are handled.
Operating the unit in such conditions may result in fire.

2. Instructions Peculiar to This Product

Note

- The product requires periodic maintenance.
Do not use the product in the following places.
Otherwise, dust adhering to the filter may not be removed and a malfunction may result because the dust can become sticky due to oil, tobacco smoke, and steam.
- Places where oil smoke is generated: Restaurants, factories, etc.
 - Smoking areas: Smoking room, etc.
 - Places with excessive special spray vapor or steam: Barber-shops, beauty salons, restaurants, laundry shops, pet shops, factories, etc.
 - Other places: Places where dust adhering to the filter becomes sticky (places including salt damage from a salty atmosphere), places where dust is generated (because the air filter cannot collect dust), server rooms (the product is not in operation during cleaning), or places where a large quantity of fine dust is generated (the air filter is clogged and the filter needs to be cleaned frequently).
- * Use the standard series for the air conditioning of the customer areas of restaurants and cafeterias.
* The product may not be used in cases other than the above.
For details, contact your dealer.

Note

- Have the customer actually operate the air conditioner while referring to the operation manual and explain the right operation of the air conditioner with useful tips given.
- Refer to the operation manual along with the installation manual provided with the indoor unit.

CONTENTS

1. Safety Considerations.....i
2. Instructions Peculiar to This Product.....i
3. Accessory2
4. Installation Site2
5. Preparations for Panel4
6. Preparations for Indoor Unit.....5
7. Attaching Panel to Indoor Unit6
8. Attaching Suction Grille and Decoration Corner Covers.....9
9. Operation Mode Settings11
10. Field Settings11
11. Test Operation12

The English text is the original instruction. Other languages are translations of the original instructions.

3. Accessory

Check that the following accessories provided with the air conditioner are correct in number. See the following illustration, which shows where the accessories are kept.

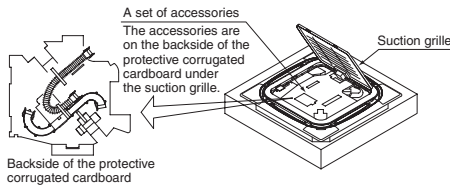

Name	Spacer (1)	Flexible hose (2)	S-shaped pipe (3)	Harness (4)	Clamp (5)
Quantity	1 pc.	1 pc.	1 pc.	1 pc.	2 pcs.
Shape					

Name	Seal (6)	Others
Quantity	1 pc.	
Shape		<ul style="list-style-type: none"> • Operation manual • Installation manual

Pay the utmost attention to the following items when conducting installation work, and recheck the items on completion of the work.

a. Test items on completion of work

Test items	In case of failure	Result
Is the air conditioner free of wiring and connection mistakes or omissions?	Operation failure and wire burnout	
Are you sure that there is no space between the ceiling and ceiling material?	Water leakage	
Are the fixing knobs (in 2 points) of the dust box secured tightly?	Vibration, noise, and dust collection failure	
Are the fixed knobs (in 5 points) of the air filter secured tightly?	Vibration, noise, and dust collection failure	
Is the fall prevention cord for the dust box and grille hooked to the mounting bracket?	Fall	
Did you attach the control box cover, dust box, flexible hose, S-shaped pipe, suction grille, and decoration corner covers?	Noise and dust collection failure	

* Be sure to recheck the items provided in the section "1. Safety Considerations" on page i.

b. Test items before delivery

Test items	Result
Was the test operation of the air conditioner finished?	
Did you explain the operation method of the air conditioner to the customer while showing the customer the operation manual? *	
Did you make mode settings for filter auto-cleaning (automatic control operation settings or timer operation settings with an operation time zone specified) and provide information on the set mode operation of the air conditioner to the customer?	
Did you deliver the operation manual to the customer? (Be sure to hand the customer the operation manual as well as the installation manual.)	

* Point of operation explanation

In addition to the general usage of the air conditioner, it is necessary to explain the descriptions of the ⚠ WARNING and ⚠ CAUTION marked items in the operation manual and have the customer read the descriptions carefully, because these items indicate information that, if not heeded, is likely to result in loss of life, serious injury, or property damage.

4. Installation Site

This product offers selectable air outlet directions. A closure kit (an optional accessory) is required to achieve three-way flow patterns. Two-way flow patterns are not available to this product.

4-1 Select the installation site that meets the following conditions with the consent of the customer

- The surface of the ceiling is not inclined.
- Installation and service workspace is secured (see the following illustrations).
- The panel indicators are seen with ease.
- The indoor and outdoor units, power cord, transmission wiring, and remote controller wiring are at least 1 m away from TV or radio sets.

(The above is for the prevention of TV and radio interference. Depending on the incoming signal strength, a distance of 1 m may not be sufficient to eliminate noise.)

4-2 Required installation space

Install the indoor unit according to the installation manual and the following illustrations.

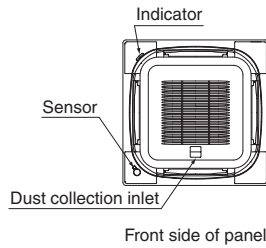

[Required installation space]

Refer to the installation instructions of the indoor unit and install the product according to the following figure.

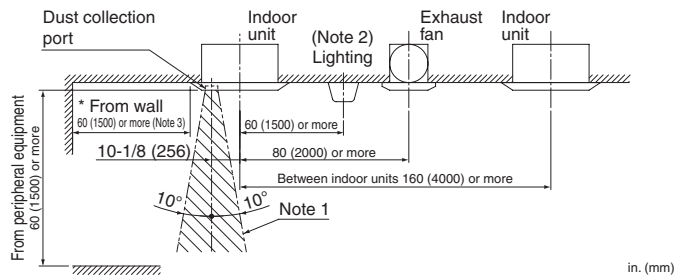

Note:

1. A space to allow dust vacuuming is required.
2. The lighting applies to exposed models (e.g., models of inverted mountain type) and there are no restrictions on embedded models (with no protrusion from the ceiling surface).
3. If the air discharge outlet is closed or the wind direction of the swing flaps are changed (to block the wind), the space marked with the asterisk (*) will be 20 in. (500 mm) or over. The space will be 8 in. (200 mm) or over if the air discharge outlet with both the left and right corners closed.
4. Refer to the operation manual provided with the remote controller for a setting method of the wind directions of the swing flap **individual wind direction settings**.

4-3 Mounting directions of suction grille

Select one of the following mounting directions of the suction grille on the panel.

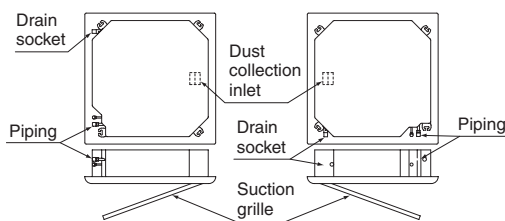

5. Preparations for Panel

Note

- Perform all the required work in "5. Preparations for Panel" on page 4 with the panel kept in the packing material (on the bottom side).
- Do not put the panel downward or upright or leave the panel on protruding parts. Otherwise, scratch damage to the surface of the panel may result.
- Do not touch the swing flap and do not apply any force on the swing flap. This may result in malfunction of the unit.

5-1 Removal of suction grille from panel, protective corrugated cardboard, and set of accessories

- (1) Press the knobs of the suction grille and lift up the knobs.

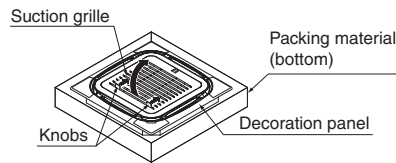

- (2) Open the suction grille to an angle of approximately 45° and remove the suction grille from the panel.

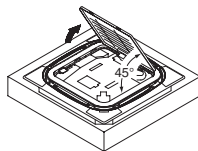

- (3) Take out the protective corrugated cardboard. Take out the protective corrugated cardboard (on top of the panel) together with the accessories attached to the backside of the protective corrugated cardboard.

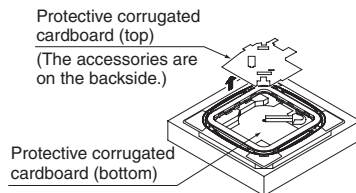

Note

Do not impose force on the swing flap, brush unit, or air filter when handling the panel.

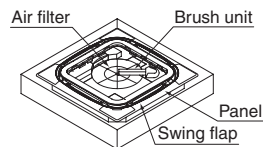

5-2 Removal of decoration corner covers

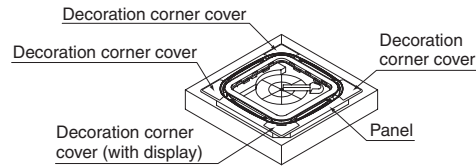

- (1) Raise and remove the decoration corner cover (with the display) in the direction of the arrow.

Note

Do not impose force on the lead wires.

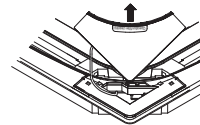

- (2) Remove the screws on the backside of the decoration corner cover (with the display), open the cover, and remove the connector attached to the front end of the lead wires from the Printed circuit board.

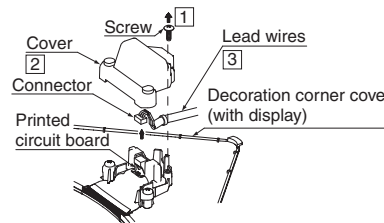

- (3) Remove each of the remaining decoration corner covers (i.e., three covers) in the direction of the arrow.

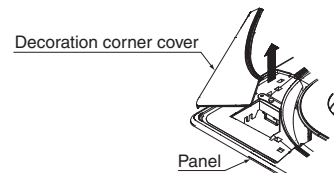

5-3 Removal of dust box

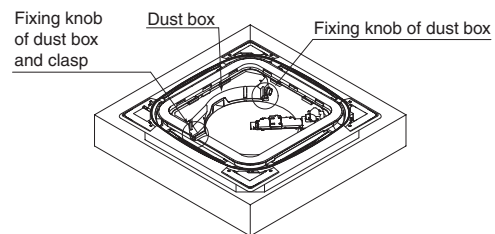

(1) Turn the 2 fixing knobs of the dust box.

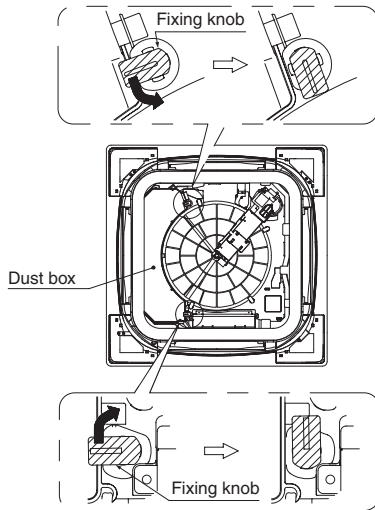

(The front side of the panel is shown for ease of explanation.)

(2) Remove the dust box from the panel while paying attention not to cut the fall prevention cord.

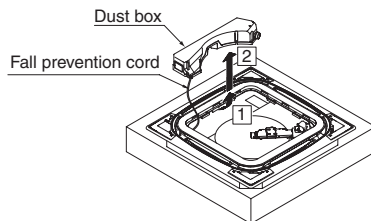

(3) Remove the fall prevention cord for the dust box from the clasp bracket of the panel.

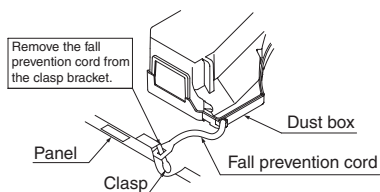

6. Preparations for Indoor Unit

— ⚠ WARNING —

Check that the indoor and outdoor units are turned power off before conducting wiring work.

Otherwise, it may result in an electric shock.

— ⚠ CAUTION —

- Conduct the following work after installing the indoor unit.
- Install the indoor unit according to the installation manual provided with the indoor unit.

6-1 Attaching spacer (accessory (1))

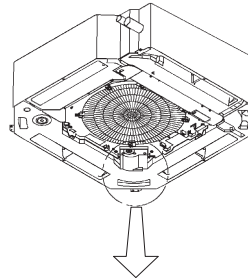

(1) Remove the bypass hole closing cap.

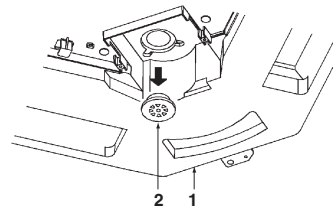

- 1 Indoor unit
- 2 Remove the bypass hole closing cap

(2) Peel off the release paper of the double-stick tape on the backside of the spacer (accessory (1)).

(3) Attach the spacer (accessory (1)) on the air bypass hole. Check that the air bypass hole is not blocked after the spacer is attached.

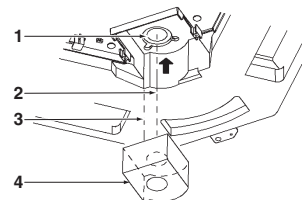

- 1 Air bypass hole
- 2 Pasted to align with the air bypass hole
- 3 Align the corners
- 4 Spacer (accessory (1))

6-2 Attaching harness (accessory (4))

(1) Remove the control box cover from the indoor unit.

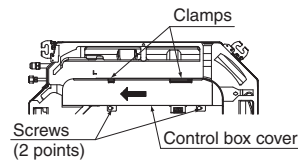

Loosen the screws (in 2 points) and slide the control box cover in the direction of the arrow to unhook the cover from the clamps.

- (2) Remove jumper connector from X8A.

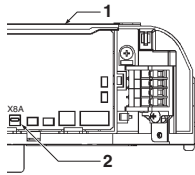

- 1 Control box
- 2 Jumper connector

- (3) Connect the harness (accessory (4)) to the connectors (X8A, X35A and X36A) and the three points of the harness on the unit side.

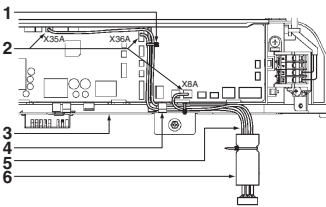

- 1 Harness on the unit side
- 2 Connector
Be sure to connect them securely
- 3 Control box
- 4 Hook X35A, X36A
- 5 Harness (accessory (4))
- 6 Glass tube

Note

Make sure that the connectors are securely connected, or otherwise the swing flap, brush unit, or air filter will not work.

6-3 Attaching control box cover

Attach the control box cover in the order opposite to the procedure in "6-2 Attaching harness (accessory (4))" on page 5 (1).

Note

Make sure that the wires or glass tube will not be caught by the control box cover.

WARNING

Arrange the electric wires neatly and attach the control box cover securely.

The electric wires being caught or the rising of the control box cover may result in an electric shock or fire.

7. Attaching Panel to Indoor Unit

Install the indoor unit by referring to the installation manual provided with the indoor unit.

Note

Do not impose force on the swing flap, brush unit, or air filter when taking out the panel from the packing material (on the bottom side).

7-1 Checks before attaching panel

- Check the directions of the indoor unit and the engraved marks on the panel as shown below.
The piping block to the [PIPING SIDE] and the drain socket to the [DRAIN SIDE].
- Stand the temporary latching bracket upright.
- Draw out the lead wires (on the panel side) from the opening.

7-2 Attaching panel

- (1) Tentatively put the two temporary latching brackets of the suction port of the panel (on the internal circumference side) to the hooks of the indoor unit.

Note

Let go your hands after confirming through the check window that the temporary latching brackets are engaged with the hooks.

- (2) Remove from the harness opening as described in "6. Preparations for Indoor Unit" on page 5. Pull out the lead wires disconnected from the decoration cover in the corner carefully so that lead wires are not caught by the mounting bracket. See "5. Preparations for Panel" on page 4.

- (3) Put the mounting brackets (in 4 points) on the corners of the panel to the hooks of the circumference of the indoor unit. (Hook the mounting bracket engraved with the [PIPING SIDE] first, followed by the mounting bracket on the opposite angle side.)
At that time, pay attention that the harness and lead wires (on the panel side) will not be caught between the panel and indoor unit.

Note

Let go your hands after confirming that the mounting brackets are engaged with the hooks.

- (4) Tighten the four hexagon head screws right under the mounting bracket for approximately 3/16 in. (5 mm.) (The panel will move upward.)
- (5) Turn the panel in the directions of the arrows so that the opening of the ceiling will be perfectly covered by the panel.
- (6) Furthermore, tighten the screw (4) until the distance from the lower part of the hook of the indoor unit to the lower part of the panel becomes 4-3/16 (107) to 4-7/16 in. (112 mm.)

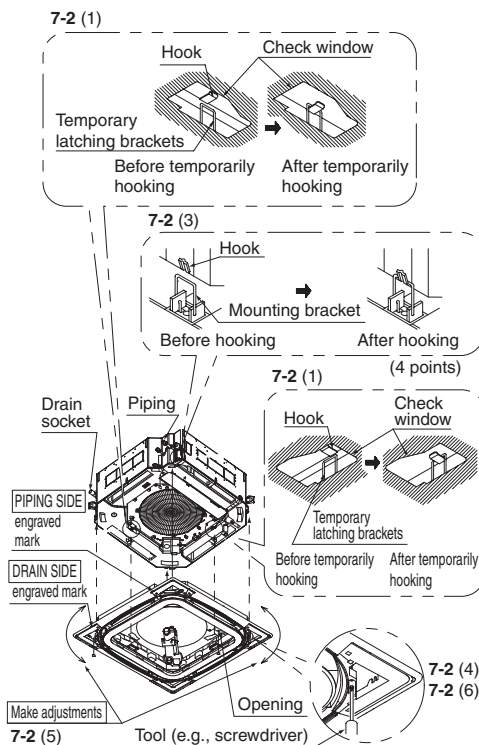

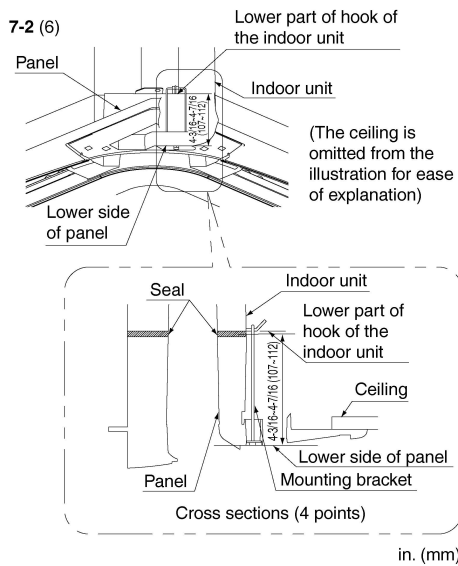

Note

- Tighten the screws securely, or otherwise a defect as shown below may result.
- Readjust the height of the indoor unit if there is a space between the ceiling and panel with the screws tightened securely.

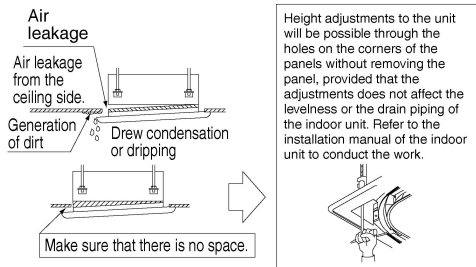

7-3 Checking panel

(1) Remove sealing of panel.

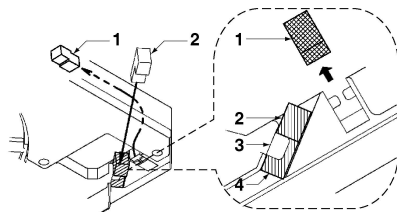

- 1 Remove seal of panel
- 2 Insert the seal until the seal comes in contact with the clamp
- 3 Clamp
- 4 Sealing (accessory (6))

(2) Draw the harness and lead wires (on the panel side).

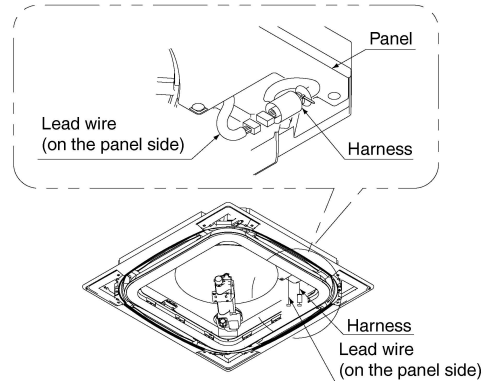

(3) Connect the connector of the lead wires and move the glass tube to cover the connector part.

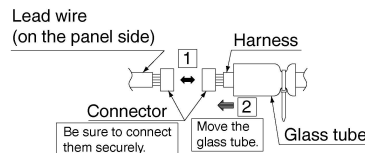

(4) Tighten and secure both ends of the glass tube with the clamps on the glass tube together with provided clamps (accessories (5)). Cut the excess portions of the clamps from their roots after the both ends are secured.

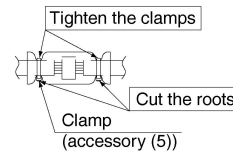

(5) Return the connected lead wires to the space between the indoor unit and panel. (Accommodate the lead wires in the shaded part shown in the illustration.)

Note

Accommodate the lead wires arrange that the lead wires do not come in contact with the air filter

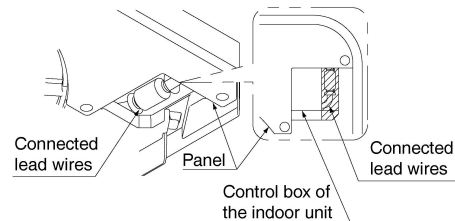

(6) Remove the control box cover from the indoor unit. Refer to "6-2 Attaching harness (accessory (4))" on page 5.

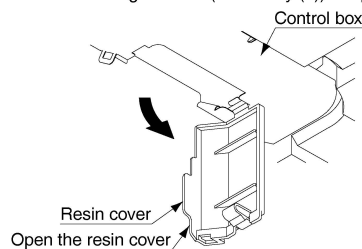

- (7) Connect the swing lead wire connector to the Printed circuit board.

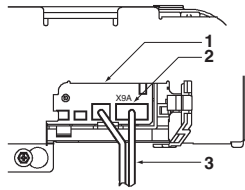

- 1 Printed circuit board
- 2 Connect the swing lead wire connector to the Printed circuit board
Be sure to connect them securely.
- 3 Swing lead wire (to X9A)

- (8) Attach the control box cover in the order opposite to the procedure in "6-2 Attaching harness (accessory (4))" on page 5.

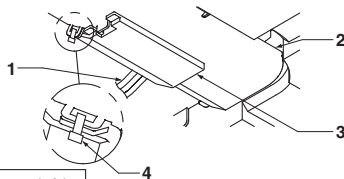

- 1 Swing motor lead wire, sensor lead wire, harness (1)
- 2 Control box
- 3 Close the resin cover
- 4 Secure with the clamp (accessory (5))

- (9) Guide the lead wires through the hook.

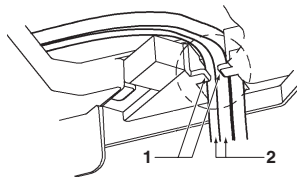

- 1 Hook
- 2 Guide the wires through the hook

7-4 Attaching dust box

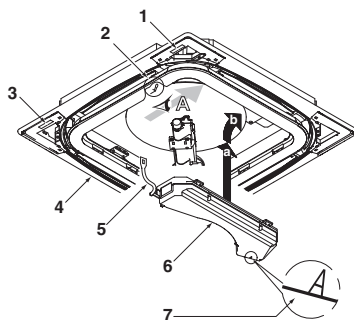

- 1 Engraved mark on piping side
- 2 Panel clasp
- 3 Engraved mark on drain side
- 4 Panel
- 5 Fall prevention cord
- 6 Dust box
- 7 Mount the dust box with the side where the mark is engraved faced downward.

- (1) Hook the fall prevention cord for the dust box to the panel clasp as shown in the illustration.

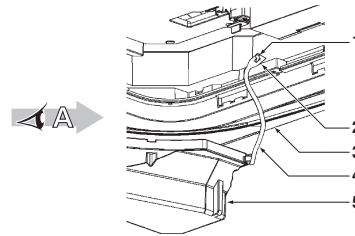

- 1 Clasp
- 2 Hooked fall prevention cord
- 3 Panel
- 4 Fall prevention cord
- 5 Dust box

- (2) Attach the dust box in the order opposite to the procedure in "5-3 Removal of dust box" on page 4.

Note

Make sure that the fall prevention cord is not caught by the exhaust opening on the dust box when attaching the dust box. Otherwise, the dust box may not function normally.

- (3) Turn the fixing knobs (in 2 points) of the dust box and secure the dust box.

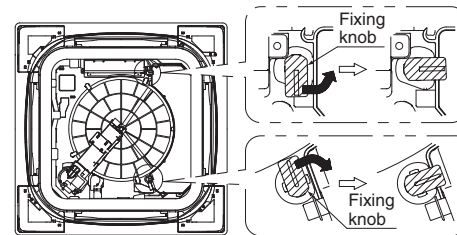

(The front side of the panel is shown for ease of explanation.)

7-5 Mounting S-shaped pipe (accessory (3))

Mount the dust box side (engraved with A) before mounting the brush side (engraved with B).

(Mount them so that the engraved characters will be in conformity.)

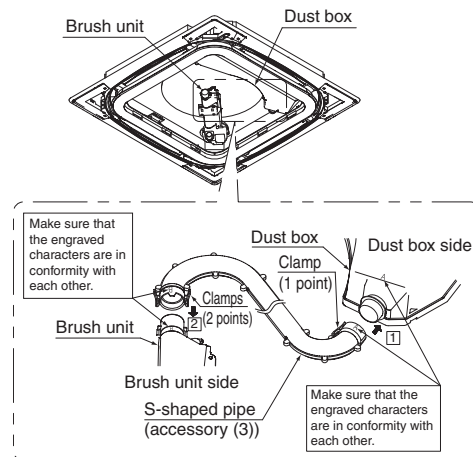

Note

Check that the clamps are engaged securely. Otherwise, a dust collection failure may result.

8. Attaching Suction Grille and Decoration Corner Covers

The suction grill can be rotated and attached in two directions, either one of which is selectable.
If a number of units are installed, adjust the directions of the suction grilles if necessary. Make directional changes as well at the request of the customer.

8-1 Attaching suction grille

* Select either the hook (A) or (B), and hook the clamps of the suction grille.

Note

The suction grille may be damaged if the wrong hooking side is selected.

8-2 Hook (A)

- (1) Set the suction grille to an angle of approximately 45° and put the hooks (in three points) onto the panel.

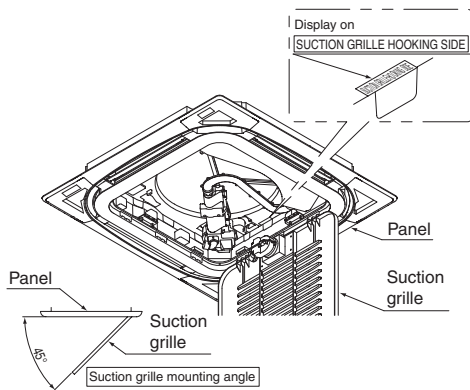

- (2) As shown in the illustration, hook the fall prevention cords for the suction grille to the corner clasps (on 2 corners).

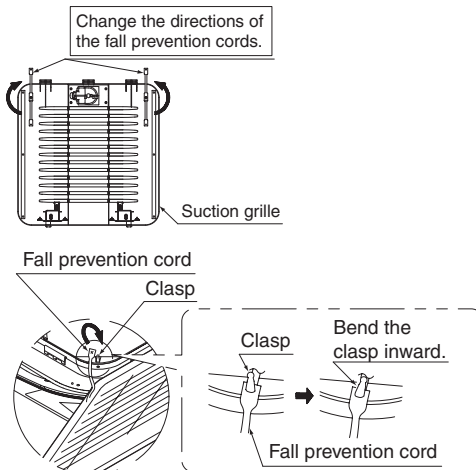

- (3) Connect the flexible hose (accessory (2)) onto the panel side.
(The flexible hose (accessory (2)) has no directionality constraint.)

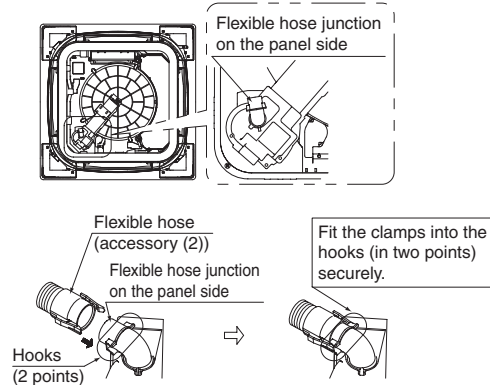

Note

Check that the clamps are engaged securely. Otherwise, a dust collection failure may result.

- (4) Press fit the flexible hose connected in (3) into the panel.
(Make sure that the hose will not be caught while closing the suction grille.)

Note

Be sure not to break the flexible hose when press fitting the flexible hose.

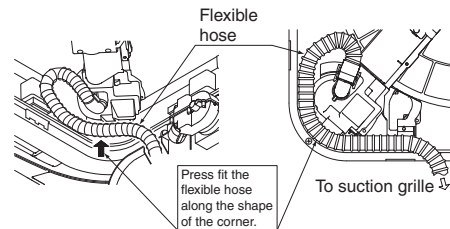

- (5) Connect the opposite end of the flexible hose connected in (3) onto the suction grille side.

* Rotate the flexible hose joint on the suction grille side according to the mounting direction of the suction grille as shown in the illustration.

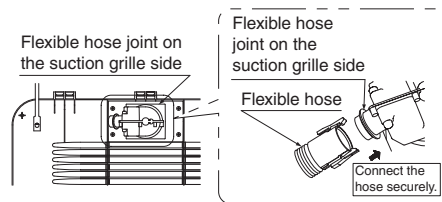

Note

Check that the clamps are engaged securely. Otherwise, a dust collection failure may result.

- (6) Push up the suction grille slowly first, and while pressing the two knobs, finally fit the grille into the panel securely.

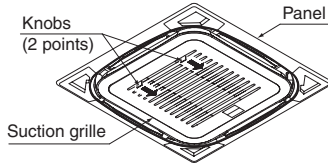

Note

The suction grille can catch the fall prevention cords while the suction grille is closed. Check that the fall prevention cords do not protrude from the suction grille before closing the suction grille.

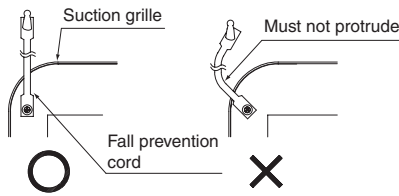

8-3 Hook (B)

- (1) Set the suction grille to an angle of approximately 45° and put the hooks (in 3 points) onto the panel.

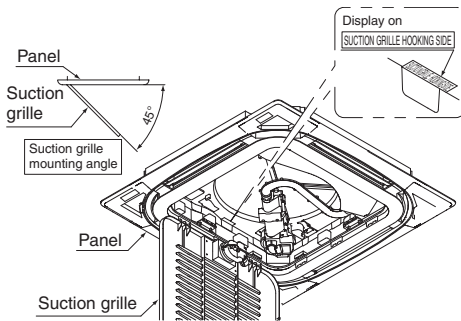

- (2) As shown in the illustration, hook the fall prevention cords for the suction grille to the corner clasps (on 2 corners).

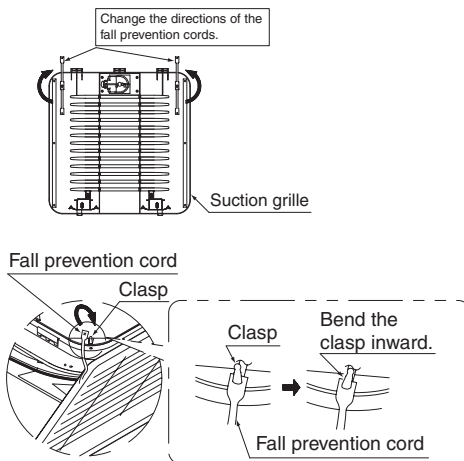

- (3) Connect the flexible hose (accessory (2)) onto the panel side. (The flexible hose (accessory (2)) has no directionality constraint.)

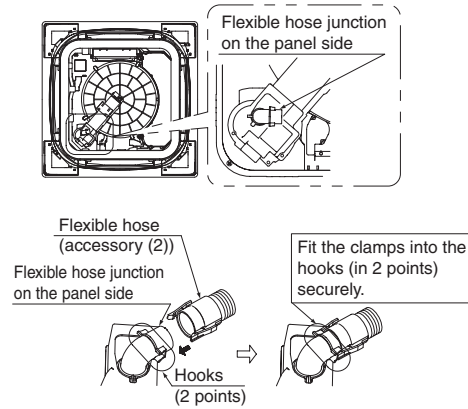

Note

Check that the clamps are engaged securely. Otherwise, a dust collection failure may result.

- (4) Press fit the flexible hose connected in (3) into the panel. Make sure that the hose will not be caught while closing the suction grille.

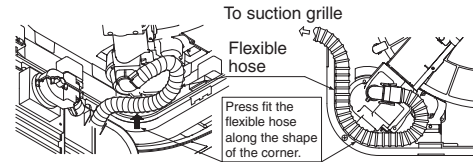

- (5) Connect the opposite end of the flexible hose connected in (3) onto the suction grille side.

* Rotate the flexible hose joint on the suction grille side according to the mounting direction of the suction grille as shown in the illustration.

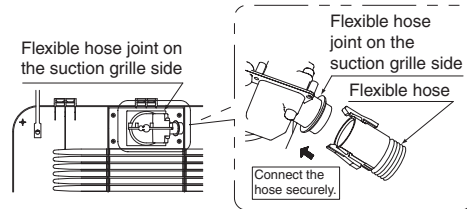

Note

Check that the clamps are engaged securely. Otherwise, a dust collection failure may result.

- (6) Push up the suction grille slowly first, and while pressing the two knobs, finally fit the grille into the panel securely.

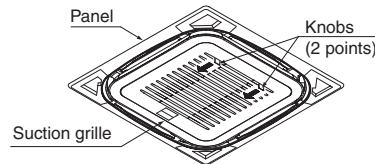

Note

The suction grille can catch the fall prevention cords while the suction grill is closed. Check that the fall prevention cords do not protrude from the suction grille before closing the suction grille.

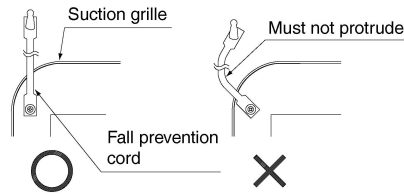

- (4) Attach the decoration corner covers (i.e., the three covers) to the panel.

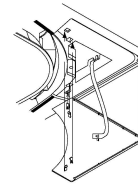

Press fit the five clamps on the decoration corner cover into the holes on the panel.

8-4 Attaching decoration corner covers

- (1) Connect the decoration corner cover (with the display) securely to the Printed circuit board in the order opposite to the procedure in "5. Preparations for Panel" on page 4.

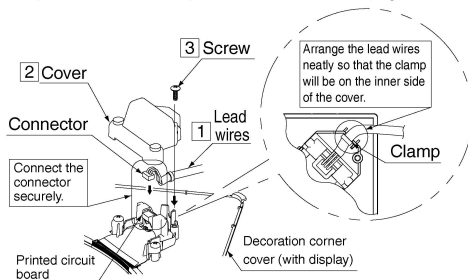

- (2) Attach the decoration corner cover (with the display) to the corner with the [DRAIN SIDE] engraved mark. Push the connected lead wires through the corner hole onto the backside of the ceiling.

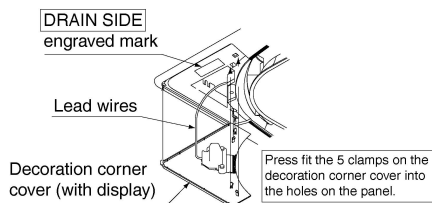

- (3) Hook each of the cords of the remaining decoration corner covers (i.e., three covers) onto the corresponding pin on the panel.

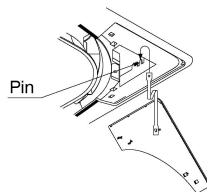

9. Operation Mode Settings

Any one of the following operation modes can be selected for the filter auto-cleaning of the self-clean panel.

Operation mode	Description
(1) Scheduled timer operation	Performs filter auto-cleaning during the designated period selected from eight periods.
(2) 00:00-to-03:00 operation	Performs filter auto-cleaning during the factory-set period of time (00:00 to 03:00).
(3) Auto control operation	Performs filter auto-cleaning according to the control reference.

In consultation with the customer, set the desired operation mode by referring to the instructions on **Filter Auto Clean** in the operation manual for the Self Cleaning decoration panel. At the time of delivery, refer to the contents of descriptions (1) through (3) in the above table and explain the customer when filter auto-cleaning will start.

10. Field Settings

Make settings in consultation with the customer according to the installation and usage conditions of the air conditioner. The following three settings are possible.

10-1 Dust quantity settings

- Make settings according to the quantity of dust in the room.
- Standard quantity of dust (General offices)
 - Large quantity of dust (Stores dealing in clothing)

10-2 Panel indicator (green) On/Off

The panel indicator (green) can display the following operating conditions. Make indicator settings according to the request of the customer.

Indicator	Operating conditions	Remarks
Green	Lit	The indicator is turned off before shipping.
	Flashing	

The red lamp to inform the customer of the time of dust collection will not be turned off.

Make field settings according to the installation manual of the remote controller. (Settings in bold cells are made before shipping.)

Setting item	Mode No.	FIRST CODE NO.	SECOND CODE NO.			
			01	02	03	04
Display Dust Collection sign 1	10 (20)	(3)	Display	No display	-	-
Dust quantity settings	14 (24)	(9)	Standard quantity of dust	Large quantity of dust	-	-
Panel indicator (green) on/off	14 (24)	(4)	On while in air-conditioning operation and filter cleaning operation.	Possible to turn on while in filter cleaning operation only.	Off while in air-conditioning operation and filter cleaning operation. * Factory settings	-

11. Test Operation

Perform the test operation of the Self-Cleaning decoration panel after the test operation of the indoor unit is finished. The test operation of the Self-Cleaning Decoration Panel is not possible while the indoor unit is in operation.

Note 

Perform the test operation of the product after referring to "a. Test items on completion of work".

11-1 Check that the control box covers of the indoor unit, outdoor unit, and self-clean panel, respectively, are closed

11-2 Turn the indoor unit power on

The panel will go into initialization operation after the power is turned on.

11-3 Conduct the test operation of the panel 2 minutes after the power is turned on

Confirm the cleaning operation of the filter with the remote controller.

Test operation method with remote controller

1. Stop the operation of the panel if the panel is in air-conditioning operation.
2. Continue pressing the Cancel button at least 4 seconds while the backlight is lit. The service settings menu will appear.
3. Select **Test Filter Auto Clean** from the service settings menu, and press the Menu/Enter button.
4. "Collect dust" will appear on the basic screen.

The display will disappear when the test operation is finished. The required test operation time is approximately 10 minutes (in the case of setting the standard quantity of dust).

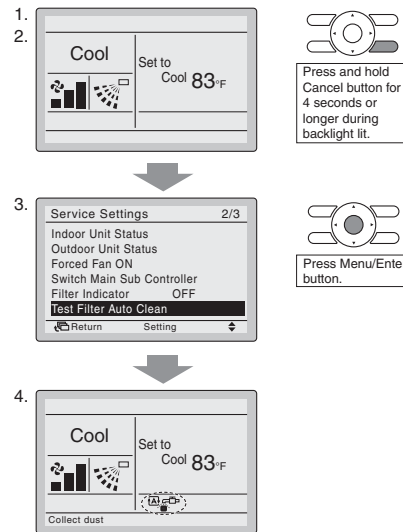

Backlight for LCD

Press any button and the backlight will be lit for approximately 30 seconds.

Perform the operation of buttons while the backlight is lit (except the On/Off button).

Test items on test operation

Test items	Remedy	Check result
Is the filter rotating?	Check the connector connections.	
Are the flaps fixed horizontally?		
Is "AH" displayed on the screen of the remote controller?		

* The remote controller will display "AH" if the self-clean panel has an error.

Note 

After the test operation of the product is finished, refer to "b. Test items before delivery" in the installation manual.

13.2 KKHAP55A160 — L-shape Extension Pipe

Daikin Air Conditioners L-type Extension pipe Operation Manual



KKHAP55A160

3P367926-1

CAUTION

- This product is designed exclusively for use of air conditioners with Self cleaning decoration panels.
- When installing, refer to the section entitled "Removing dust from the dust box" in the Self cleaning decoration panel instruction manual.
- Store the L-type extension pipe with the connecting pipe (KKHAP55B160 : Option parts) attached.
- Store this instruction manual together with the instruction manuals for the Self cleaning decoration panel and the connecting pipe.

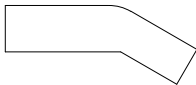
Package contents Ensure that the package contains the following parts:

Name	L-type extension pipe	Instruction manual
Shape		
Quantity	1	1 (this manual)

1 Instruction

- (1) Attach the L-type extension pipe along with the connecting pipe (KKHAP55B160) (Option parts) to the tip of the vacuum cleaner pipe.

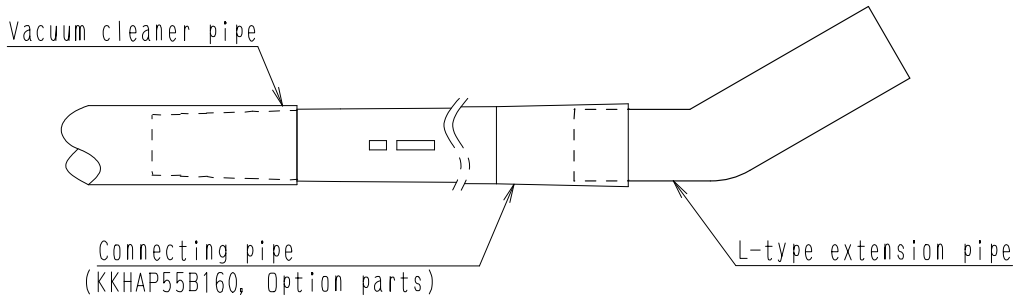

- (2) Insert the L-type extension pipe with the pipe tip faced right below the collection inlet of the suction grill.

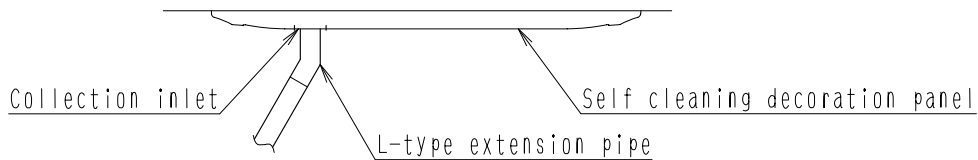

13.3 KAFP554A160 — Replacement Filter for Self Cleaning Decoration Panel

Daikin Air Conditioners Replacement Air Filter Installation Manual

KAFP554A160
Please read before installing the replacement air filter and follow all instructions.
1P367830-1

CAUTION

- This product is designed exclusively for use of air conditioners with Self cleaning decoration panels (BYCP160KGF/KAGF, BYCP160BGF/DAGF/DEGF, and BYCQ125BGW1).
- When installing, refer to the indoor unit's installation manual.

Package contents Ensure that the package contains the following parts:

Name	Replacement air filter	Installation manual
Shape	1	2
Quantity	1	1 (this instructions)

1 Preparation before replacing the air filter

<1> Open the suction grille.
Push up on the two tabs on the suction grille and open it. (See Figure 1.)

(Figure 1)

<2> Remove the S-shaped pipe.
Remove the S-shaped pipe as described below. (See figure 2.)

- Disconnect the S-shaped pipe from the brush unit side (the side marked with "B") by pulling on it while pressing down on the clips on the end of the pipe.
- Disconnect the S-shaped pipe from the dust box side (the side marked with "A") by pulling on it while pressing down on the clip on the end of the pipe.

(figure 2)

<3> Remove the dust box.
Remove the dust box as described below.

- Rotate the two clips that hold the dust box in place. (See Figures 3 and 6.)
- Remove the dust box without cutting the string that prevents the panel from falling off. (See Figure 4.)
 - Tilt the dust box about 45°
 - Remove the dust box.
- Detach the piece of string from the panel mounting bracket. (See Figure 5.)

(Figure 3)

<4> Move the brush unit.

- Rotate the clip in area (A) that holds the air filter in place. (See Figure 6.)
- Turn the knurled screw in the center of the air filter by hand to loosen it. (See Figure 6.) (Do not remove the knurled screw.)
- Rotate the brush unit in the direction indicated by arrow (C) until it stops while pushing up on area (B). (See Figure 7.)
- Pull down slightly the entire brush unit away from the air filter (About 20 mm (3/4 in.) gap will open up between the air filter and the brush unit) (See Figure 4.)
- Rotate the brush unit from its orientation at the end of step (4) until it is positioned as illustrated in Figure 7.

(Figure 4)

(Figure 6) (Figure 7)

2 Replacing the air filter

(6) Rotate the four clips that hold the air filter in place and remove the air filter.

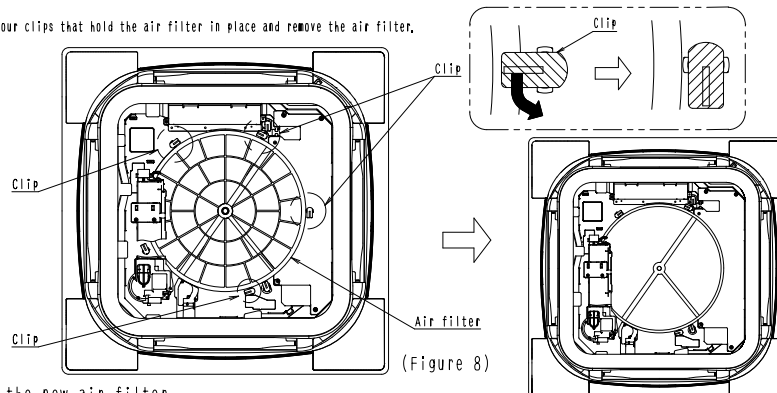

(Figure 8)

<5> Install the new air filter

(1) Place the replacement air filter (Accessory 1) onto the knurled screw.

(2) Rotate the clips to lock the filter in place by reversing step <4>-<6> above.

- Make sure that the clips are locked in the orientation shown in the figure.
- Failure to do so may result in damage to the air filter.

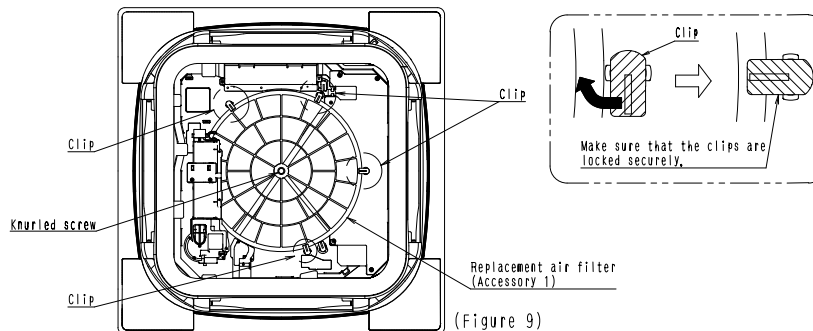

(Figure 9)

(3) Return the brush unit to its original position by reversing steps <4>-<1> through <5> above and tighten the knurled screw.

- When proceeding from step (4) to step (3), be sure to push up on area B toward the air filter before rotating the brush unit. Failure to do so may result in damage to the filter unit.
- Attach the brush unit securely.
- Failure to do so may result in damage to the air filter or cause the air conditioner to malfunction.

(4) Lock the clips in area (A) shown in Figure 6 by repeating step (2) above.

- Make sure that the clips are locked in the orientation shown in the figure.
- Failure to do so may result in damage to the air filter.

3 After replacing the air filter

<1> Attach the dust box and S-shaped pipe

Reattach the dust box and S-shaped pipe by reversing the steps described in "3" Remove the dust box "and" 2" Remove the S-shaped pipe" under

1 Preparation before replacing the air filter

- Attach the dust box securely.
- Failure to do so may prevent dust from being collected properly.
- Verify that the clips on the S-shaped pipe are securely engaged.
- Failure to do so may prevent dust from being collected properly.

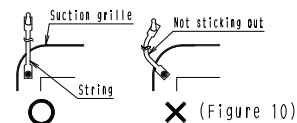

<2> Close the suction grille.

Close the suction grille by reversing the steps described in "1" Open the suction grille" under 1 Preparation before replacing the air filter

- When closing the suction grille, the piece of string that keeps the panel from falling off could become caught between the grille and the air conditioner frame. (See Figure 10.) Before closing the grille, make sure that the string is not hanging out of the suction grille.

1P367830-1



Warning



- Ask a qualified installer or contractor to install this product. Do not try to install the product yourself. Improper installation can result in water or refrigerant leakage, electrical shock, fire or explosion.
- Use only those parts and accessories supplied or specified by Daikin. Ask a qualified installer or contractor to install those parts and accessories. Use of unauthorised parts and accessories or improper installation of parts and accessories can result in water or refrigerant leakage, electrical shock, fire or explosion.
- Read the user's manual carefully before using this product. The user's manual provides important safety instructions and warnings. Be sure to follow these instructions and warnings.

If you have any enquiries, please contact your local importer, distributor and/or retailer.

Cautions on product corrosion

1. Air conditioners should not be installed in areas where corrosive gases, such as acid gas or alkaline gas, are produced.
2. If the outdoor unit is to be installed close to the sea shore, direct exposure to the sea breeze should be avoided. If you need to install the outdoor unit close to the sea shore, contact your local distributor.