

JQE-103

406MHz SATELLITE EMERGENCY POSITION INDICATING RADIO BEACON
(406MHz Satellite EPIRB)

OPERATION MANUAL



Japan Radio Co., Ltd.

Actual Producer : MITSUBISHI ELECTRIC TOKKI SYSTEMS CORPORATION

PREFACE

Thank you for purchase of the JQE-103 406MHz EMERGENCY POSITION INDICATING RADIO BEACON (Satellite EPIRB).

It is designed for use by mariners in distress to initiate the transmission of an emergency distress locating signal to the Satellites.

- Please read this Operation manual carefully and carry out proper operation.
- Please keep the manual importantly to refer when it is necessary.
- Please use it when questions and troubles are caused in operation, by any chance.

ATTENTIONS BEFORE USING

- JRC cannot accept responsibility for any loss due to incorrect operation, malfunction and other causes except product guarantee condition and liability by law.
- Specifications of Satellite EPIRB and its accessories may change without notice for improvement.

ABOUT WARNING LABELS AND IDENTIFICATION PLATES

<Attached to Satellite EPIRB main body>

(1)

WARNING	USE ONLY DURING SITUATIONS OF GRAVE AND IMMINENT DANGER.
<p>● AUTOMATIC OPERATION</p> <ol style="list-style-type: none"> 1. Set EPIRB into AUTOMATIC RELEASE BRACKET. 2. Confirm switch is "READY". 3. EPIRB deploy automatically when at depth of less than 4 meters. 4. To stop transmission, raise the EPIRB above water. 	<p>● MANUAL OPERATION</p> <ol style="list-style-type: none"> 1. Turn switch to "ON". 2. To stop transmission, raise the EPIRB above water, turn switch to "READY". <p>● SELF-TEST OPERATION</p> <ol style="list-style-type: none"> 1. Turn switch to "TEST" and hold. 2. Confirm LED lit.

(2)

JRC SATELLITE EPIRB JQE-103		P-35 LiMnO₂ BATTERY EXPIRY DATE
Operating temp. range	-20°C ~ +55°C CLASS II	 0168 15
Compass safe distance	1.0meter	
Minimum duration time	48hour	
BEACON ID	_____	
RADIO CALL SIGN	_____	NAME OF VESSEL _____
Return to service agent if self-test falls and for battery replacement. Contains LiMnO ₂ battery. Do not recharge, disassemble, short, expose to high temperatures or incinerate.		

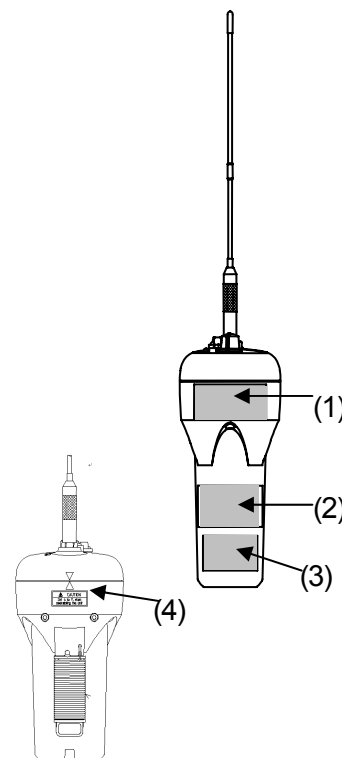

(3)

SATELLITE EPIRB JQE-103		
COMPLIED WITH IMO Res.A.810(19)		
C/S TAC 164		
MIC APPROVAL NO. SE05002		
APPROVED TYPE SES5AE3-406-5-4		
APPROVAL DATE 22 SEP,2005		
MFG. MITSUBISHI ELECTRIC TOKKI SYSTEMS CORPORATION SERIAL NO. _____		
SELL. Japan Radio Co.,Ltd. M.F.G. DATE _____		
MODEL JQE-103		
MLIT APPROVAL NO.5351		
MADE IN JAPAN		

(4)

▲
⚠ CAUTION
Set ▲ to ▼, when assembling the unit.

<Attached to Automatic Release Bracket>

(5)

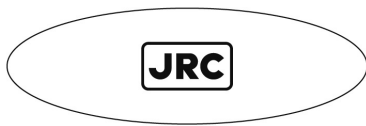

(7)

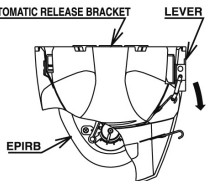

Manual Release
Remove "R" pin. Turn a buckle lever toward an arrow as shown in this figure. The EPIRB can be removed from the AUTOMATIC RELEASE BRACKET.
HYDROSTATIC RELEASE EXPIRY DATE

(6)

 警告 WARNING
・手すりなどの振動の激しい場所へは装備しないでください。 ・EPIRBの清掃に溶剤（シンナー・アルコール・油落とし等）、アルカリ性/中性洗剤を使用しないでください。 ・Do not install EPIRB an extremely vibrating place such as a handrail. ・Do not use a solvent (paint-thinner, alcohol etc.) or alkali/neutral detergent to clean up the EPIRB.

(8)

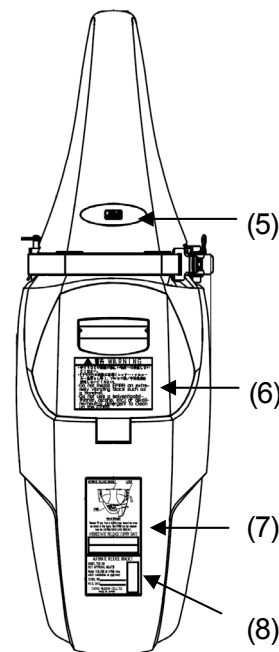
NYH-12 AUTOMATIC RELEASE BRACKET	
MLIT APPROVAL NO.5353	
Model JQE-103 of EPIRB from which installation is approved.	
SERIAL NO. _____	
M.F.G. DATE _____	
MFG. MITSUBISHI ELECTRIC TOKKI SYSTEMS CORPORATION	
SELL. Japan Radio Co.,Ltd.	
MADE IN JAPAN	





BEFORE OPERATION

About safety symbols

This manual and the terminal are indicated the following safety symbols for your correct operation to prevent your and somebody's injury or damage to the product and assets.

The symbols and descriptions are as follows.

You should understand well them before reading this manual and operating the terminal.

 DANGER	This symbol denotes that improper handling poses a high risk of causing death or serious injury.
 WARNING	This symbol denotes that improper handling poses a risk of causing death or serious injury.
 CAUTION	This symbol denotes that improper handling poses a risk of causing injury or damage to the product and/or assets.

Example of symbols



The \triangle symbol denotes DANGER, WARNING or CAUTION.
The inside illustration of the \triangle symbol denotes meaning of the DANGER, WARNING or CAUTION more concretely. (this example warns of possible electrical shock.)



The \otimes symbol denotes prohibited action.
The inside illustration of the \otimes symbol denotes the specific prohibited action more concretely. (this example indicated disassembly is prohibited.)



The \bullet symbol denotes obligatory operation or instruction.
The inside illustration of the \bullet symbol denotes obligatory operation or instruction more concretely. (this example indicates unplugging is the obligatory instruction.)

WARNING



<Use of Main body>

If the false distress alert is transmitted, take the following instructions immediately.

- (1) Stop the transmission immediately.
- (2) Report the following information to the Maritime Safety Agency.
 - (a) Ship's Name, Type and Flag
 - (b) MMSI (Maritime Mobile Service Identification) of Satellite EPIRB
 - (c) Position and Time at the false transmission
 - (d) Cause of the false transmission
 - (e) Type, Serial Number and Delivery Date of the Satellite EPIRB

(Information addressee)

- (1) In Japan, contact to the Japan Coast Guard & Rescue Department.

(TLX: +72-222-5193 JMSAHQ J, TEL: +81-3-3591-6106)

- (2) For outside of Japan, contact to the closest coast guard agency or equivalent organization in the country.



To throw down this unit on the surface of the sea, it must be dropped from the 20 meters or less height on the sea. Do not absolutely throw down this unit when the surface of the sea is frozen over as the unit may be damaged.



If the Satellite EPIRB is taken out from water in distress, it stops sending distress signals. Do not pull up the Satellite EPIRB from water during emergencies.



This unit must not be used for other than emergency disaster. Otherwise, a large trouble will be given to the search rescue organization.

<Use of Selector switch>



Do not set the selector switch to "ON" except the case of manual activation in the emergency. Distress signals are emitted when turning the selector switch "ON".



Confirm that the selector switch is set to "READY", and the Satellite EPIRB is not wet, when the Satellite EPIRB main body is removed from automatic release bracket except in the emergency.



The selector switch is set to "READY" position at factory. Do not turn the selector switch to "ON" unless in case of emergency.



The selector switch must be set to the "READY" position while sailing.

WARNING



<Use of Hydraulic pressure sensor>

The hydraulic pressure sensor activates the cutter using spring force.
Do not disassemble the hydraulic pressure sensor, nor apply pressure to it. Serious injury could result.



Once the hydraulic pressure sensor operates, it cannot be reused.
Be careful for Satellite EPIRB so as not to be stolen or not to be activated by mischief when the ship is in port.



<Installation: Main body>

Confirm that the ship's name and ID correspond to those indicated on the label of the Satellite EPIRB main unit. Rescue work will be planned and executed based on the information of ship's name and ID sent from the Satellite EPIRB. Proper planning of rescue work would not be possible if ship's name and ID are wrong.

If the ship's name and ID indicated on the label of the Satellite EPIRB main unit is wrong, ask the purchasing dealer, JRC agent or one of the JRC branches to change it with correct ship's name and ID.



When the ship meets disaster, a large trouble will be given to the search rescue organization when ship information on Satellite EPIRB is wrong.
Remove the Satellite EPIRB if MMSI/new ship name cannot be renewed.



This unit may be damaged due to vibration.
Do not absolutely install this unit in an extremely vibrating place such as a handrail.



This unit must not be installed in a place where a strong magnetic field is generated. The Satellite EPIRB may activate by the magnetic force.



The Satellite EPIRB must be installed apart from the compass and so for the 2 meters or more so that the magnetism is not influenced. The magnet in the automatic release bracket may affect the compass and so forth.



This unit must not be used in a poor-view place such as a control room, engine room and survival boat (with metal canopy) that may prevent the distress signal from reaching. We recommend that this unit is used on a wide-view deck, bridge, or on the surface of the sea.



Mount the Satellite EPIRB main unit on the automatic release bracket properly.
Improper mounting causes the Satellite EPIRB not to be automatically released from the bracket in an emergency.



<Installation: Battery and Hydraulic pressure sensor>

The battery and hydraulic pressure sensor which expired effective periods expired must not absolutely be used. If such battery and sensor are used, the distress signal may not be emitted at the emergency disaster. Take care that their lives do not expire.



It is strongly prohibited to install old ID's Satellite EPIRB removing its battery only.

WARNING

<Installation: Lanyard>



Never connect the lanyard to the automatic release bracket or ship body. It disturbs the automatic release at emergency.

<Maintenance: Main body>



Ask the maintenance of Satellite EPIRB to the purchasing dealer, JRC agent or one of the JRC branches. This device is used in urgent accident, and equipment should ensure it.



The Satellite EPIRB needs to have periodical maintenance at a service shop authorized by local authority at regulated interval.

The Satellite EPIRB may not be activated at the emergency if there is a trouble in the equipment. And there is a possibility not to be able to inform the distress to the search rescue organization.



Do not continue to use the Satellite EPIRB when deterioration in the performance is found at periodical maintenance.

The Satellite EPIRB may not be activated at the emergency if there is a trouble in the equipment. Also, confusion of search and rescue operations might happen by false transmission. Repair or replace when deterioration in the performance is found.



Do not troubleshoot or repair the internal equipment of the Satellite EPIRB by yourself. Any electrical work by any person other than our trained maintenance staff may cause fire or abnormal operation of this equipment or electrical shock for you.



Do not disintegrate this equipment. Electronic circuit which generates high voltage is exist inner main body of Satellite EPIRB. There is a possibility that Satellite EPIRB cannot keep the watertight and cannot actuate correctly, if it is disintegrated without reason.



Do not adjust the internal circuit without a calibrated measuring instrument or exchange the parts because the internal circuit is adjusted finely to specifications. If the equipment works abnormally, please contact the purchasing dealer, JRC agent or one of the JRC branches.

<Maintenance: Conductive switch terminal>



The Satellite EPIRB may not transmit the distress signal even if it is on the water when the conductive switch terminal is smeared by oily dust. Perform periodical cleaning of the Satellite EPIRB in accordance with the procedure described in section 4-3.



The distress signal may transmit by removing the Satellite EPIRB main unit from the automatic release bracket when the conductive switch terminals are covered by wet salt. Perform periodical cleaning of the Satellite EPIRB in accordance with the procedure described in section 4-3.

<Abandonment: Main body>



Request abandonment to the purchasing dealer, JRC agent or one of the JRC branches for the disused Satellite EPIRB.

There is a possibility that the emergency beacon is transmitted from disused Satellite EPIRB when it is disposed improperly. If the emergency beacon is transmitted by improper disposal, large confusion is caused in search and rescue operations.

WARNING

<Abandonment: Battery>



Do not make the used battery to short-circuit, discharging electricity compulsorily or using for other usages. Send used batteries to the purchasing dealer, JRC agent or one of the JRC branches.



Do not discard used batteries. Send used batteries to the purchasing dealer, JRC agent or one of the JRC branches, to avoid causing environmental problem by throwing them away.

<Procedure when sell the ship>



Ask the procedures (submitting continuous usage or abandonment of radio station license, and confirmation of continuous usage of Satellite EPIRB) and works (returning or abandonment of equipment, rewriting MMSI of inner main body, and installation to the new ship) to purchasing dealer, JRC agent or one of the JRC branches (refer to CHAPTER 4-7, After Service)

If these procedures and works are not executed, false transmission or wrong ID code signal might be emitted in distress, and it causes serious confusion for search and rescue operation. Also the owner of the vessel will receive strict warning from the organization that manages the search and rescue operation for marine vessel.



When an existing Satellite EPIRB is resold to another ship, the MMSI and ship name of the Satellite EPIRB must be changed. It sometimes happens that the MMSI and ship name of Satellite EPIRB is not changed as following reasons.

New ship name is undecided yet.

New MMSI cannot be acquired.

Ship's dealer is taking necessary procedures.

New MMSI is not acquired yet, but Satellite EPIRB is included in the sales contract of the used vessel.

CAUTION



Open slowly the cover of release bracket.
If you open faster, EPIRB main unit may deviate from release bracket and fall down.



<Executing test>

In this test, permitted distress signal for the test purpose is transmitted only by one burst.
Do not execute the test repeatedly in a short time frame.



Execute the test in 00 - 05 minutes of each o'clock for the reduction of processing capacity in the satellite.



This test must not be performed, as the Satellite EPIRB main unit remains removed from the automatic release bracket. The distress signal may erroneously be emitted.



<Warning label>

Do not remove, destroy, or modify warning labels.



Ask purchasing dealer, JRC agent or one of the JRC branches to replace any stained, illegible, or damaged label if it can affect maintenance and use.

<Others>



Ask the service to purchasing dealer, JRC agent or one of the JRC branches if the battery, hydraulic pressure sensor or stopper pin is replaced or the abnormal status is recognized in the Satellite EPIRB.



If you want to replace or repair the battery or hydraulic pressure sensor, contact the purchasing dealer, JRC agent or one of the JRC branches.



Do not wipe the both of conductive switch terminals in the same time.
It might cause the false transmission of distress signal due to the sensor detects the water and activated.



Do not wipe the Satellite EPIRB with seawater. If the salt content is adhered to the Satellite EPIRB, It might cause the false transmission.



Never loosen the conductive switch terminal.
There is a possibility of not transmitting the signal at emergency if the conductive switch terminal is loosened.



Take care not to get hurt at the end of the antenna or band of the automatic release bracket.



Do not use a solvent (paint-thinner, alcohol etc.) or alkaline/neutral detergent to clean up the Satellite EPIRB.
It causes crack on the resin if such a detergent is used, and Satellite EPIRB may not operate properly in the worst case by leaking etc.

APPEARANCE

Satellite EPIRB



Fig.1 Satellite EPIRB

Automatic release bracket



Fig.2 Automatic release bracket

GLOSSARY

EPIRB

Emergency Position Indicating Radio Beacon

GMDSS

Global Maritime Distress and Safety System

Cospas-Sarsat

International satellite system for maritime search and rescue

LEOSAR

Low-Earth-Orbit Satellite System for Search and Rescue

MMSI

Maritime Mobile Service Identity

SAR

Search And Rescue

OPERATION AT EMERGENCY (MANUAL ACTIVATION)

Turn the stopper to arrow mark direction breaking the stopper pin.

Turn ON the selector switch. Then, the indication lamp flashes and distress signal is transmitted for over 48 hours. After setting, turn the stopper back to original position to keep switch ON.

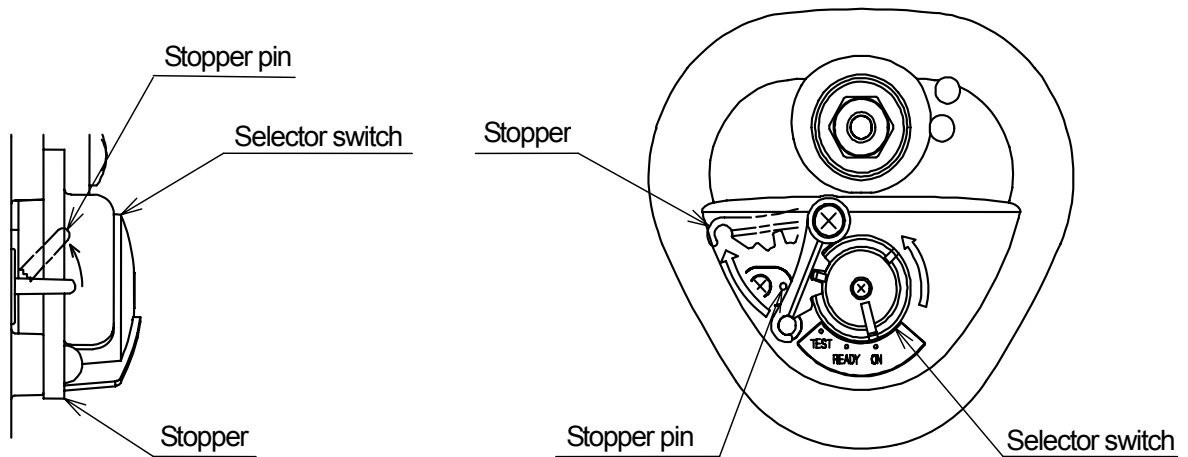

Operation of the selection switch is available by opening the hatch of the automatic release mounting bracket.

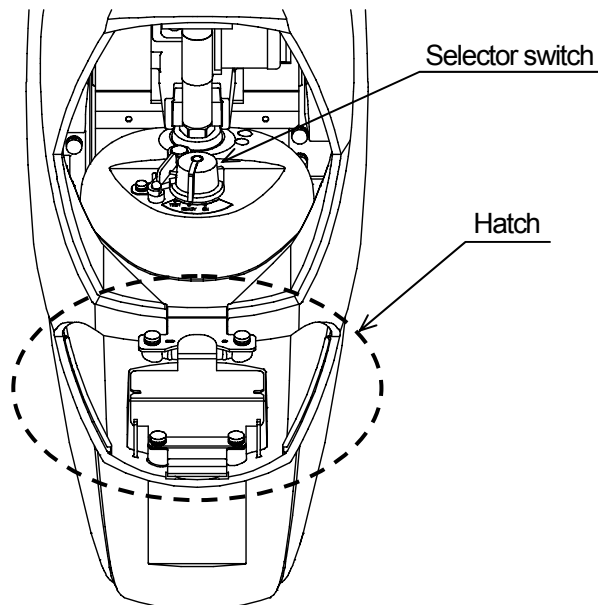

Fig.3 Operation procedure at emergency

CONTENTS

PREFACE.....	i
ATTENTIONS BEFORE USING.....	i
ABOUT WARNING LABELS AND IDENTIFICATION PLATES	ii
BEFORE OPERATION.....	iii
CAUTIONS DURING OPERATION.....	iv
APPEARANCE.....	ix
GLOSSARY	x
OPERATION AT EMERGENCY (MANUAL ACTIVATION).....	xi
CHAPTER 1. INTRODUCTION.....	1-1
1.1 System Outline.....	1-1
1-2 Feature of Satellite EPIRB	1-2
1-3 Configuration.....	1-3
1-3-1 Components.....	1-3
1-3-2 Satellite EPIRB main unit	1-4
1-3-3 Automatic release bracket	1-5
CHAPTER 2. INSTALLATION.....	2-1
2-1 Checking of the components.....	2-1
2-2 Caution of installation.....	2-1
2-3 Outline of installation.....	2-2
CHAPTER 3. OPERATION.....	3-1
3-1 Selector switch.....	3-1
3-2 Power OFF.....	3-2
3-3 Manual activation.....	3-3
3-4 Automatic activation.....	3-4
3-5 Lanyard.....	3-5
3-6 Test.....	3-6
3-7 Mounting of the Satellite EPIRB main unit into automatic release bracket.....	3-8

3-8	Removal of Satellite EPIRB main unit from automatic release bracket.....	3-12
CHAPTER 4.	IMPLEMENTATION / MAINTENANCE / CHECK / CLEANING	4-1
4-1	Implementation.....	4-1
4-2	Maintenance.....	4-2
4-3	Periodical cleaning of conductive switch terminal.....	4-3
4-4	Test.....	4-5
4-5	Parts for periodical replacement.....	4-5
4-6	Cleaning of Satellite EPIRB main unit.....	4-6
4-7	After service.....	4-7
4-7-1	Longevity/exchange time of Satellite EPIRB.....	4-7
4-7-2	How to discard the Satellite EPIRB.....	4-7
4-7-3	Necessary procedure for Satellite EPIRB installed in the vessel to be resold.....	4-9
CHAPTER 5.	SPECIFICATIONS	5-1
5-1	Electrical specifications	5-1
CHAPTER 6.	JRC SERVICE NETWORK	6-1

1.1 System Outline

Satellite EPIRB is a beacon installed onto the ship under GMDSS rule. Should the ship sink, the Satellite EPIRB will automatically float on the water, emit 406.028 MHz and 121.5 MHz distress beacon for over 48 hours.

The 406.028 MHz beacon is received by LEOSAR of the COSPAS/SARSAT system, and distress position is measured by Doppler effect between moving speed of the satellite and rotation of the earth.

This emergency information (i.e. position data and MMSI) is relayed to the Local User Terminal (LUT).

The emergency information is also relayed to the Rescue Coordination Centers (RCC) for SAR activity in all over the world through Mission Control Center (MCC).

The 121.5 MHz homing beacon is used to detect the direction in a short distance so that the emergency can easily be searched from an aircraft and ship at the scene.



1-2 Feature of Satellite EPIRB

The Satellite EPIRB emergency position indicating radio beacon has the following features.

- Emitting 2 types of distress signals: 406.028 MHz and 121.5 MHz
- The Satellite EPIRB main unit attached to the automatic release bracket is automatically released within water depth 4 meters and sends two types of distress signals.
- After release from the automatic release bracket, the Satellite EPIRB main unit starts to send distress signals upon sensing water. If the Satellite EPIRB main unit is removed from the automatic release bracket on board the ship by mistake, it sends no distress signal.
- Manual activation to send distress signal is possible by turning selector switch ON.
- The transmitting of the 406.028 MHz distress signal starts 50 seconds after the power has been turned on, and then the 0.44 second distress signal is repeatedly sent at 50 second intervals for 48 or more hours.
- The transmitting of the 121.5MHz distress signal starts 50 seconds after the power has been turned on, and then it is continuously sent for 48 or more hours.
- This unit normally operates even if it is dropped from the 20 meters height on the surface of the sea.
- This unit continuously operates at the temperature ranging from -20°C to +55°C for 48 or more hours.

1-3 Configuration

1-3-1 Components

Table 1-3-1 Components list

Name	Dimension, etc.	Weight	Q'ty
JQE-103 Satellite EPIRB (including antenna)	120(W) x 529(H) x 116(D) mm	Approx. 1.3 kg	1
NYH-12 Automatic release bracket	175(W) x 585(H) x 175(D) mm	Approx. 2.9 kg	1
Installation materials	Stainless bolt with hexagonal hole (M6x20) Stainless nut (M6x1) Stainless washer (M6x1) Stainless spring washer (M6x1)	—	4 each. (3 is needed and 1 for spare)
Operation manual	7ZPSC0215A	—	1
Quick reference operation guide	7ZPSC0218	—	1
Installation manual	7ZPSC0217	—	1
Test data sheet	—	—	1

1

1-3-2 Satellite EPIRB main unit

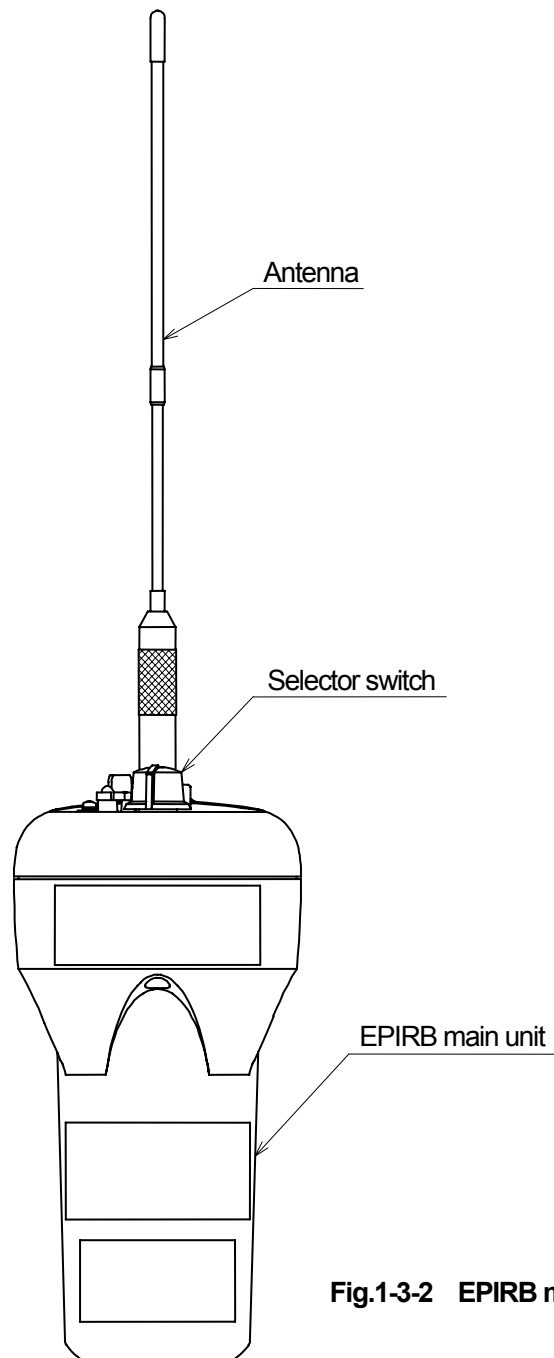
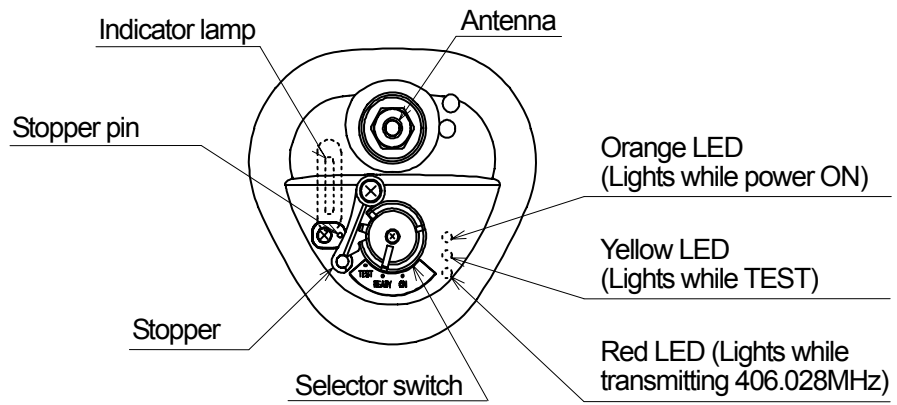

Fig.1-3-2 EPIRB main unit

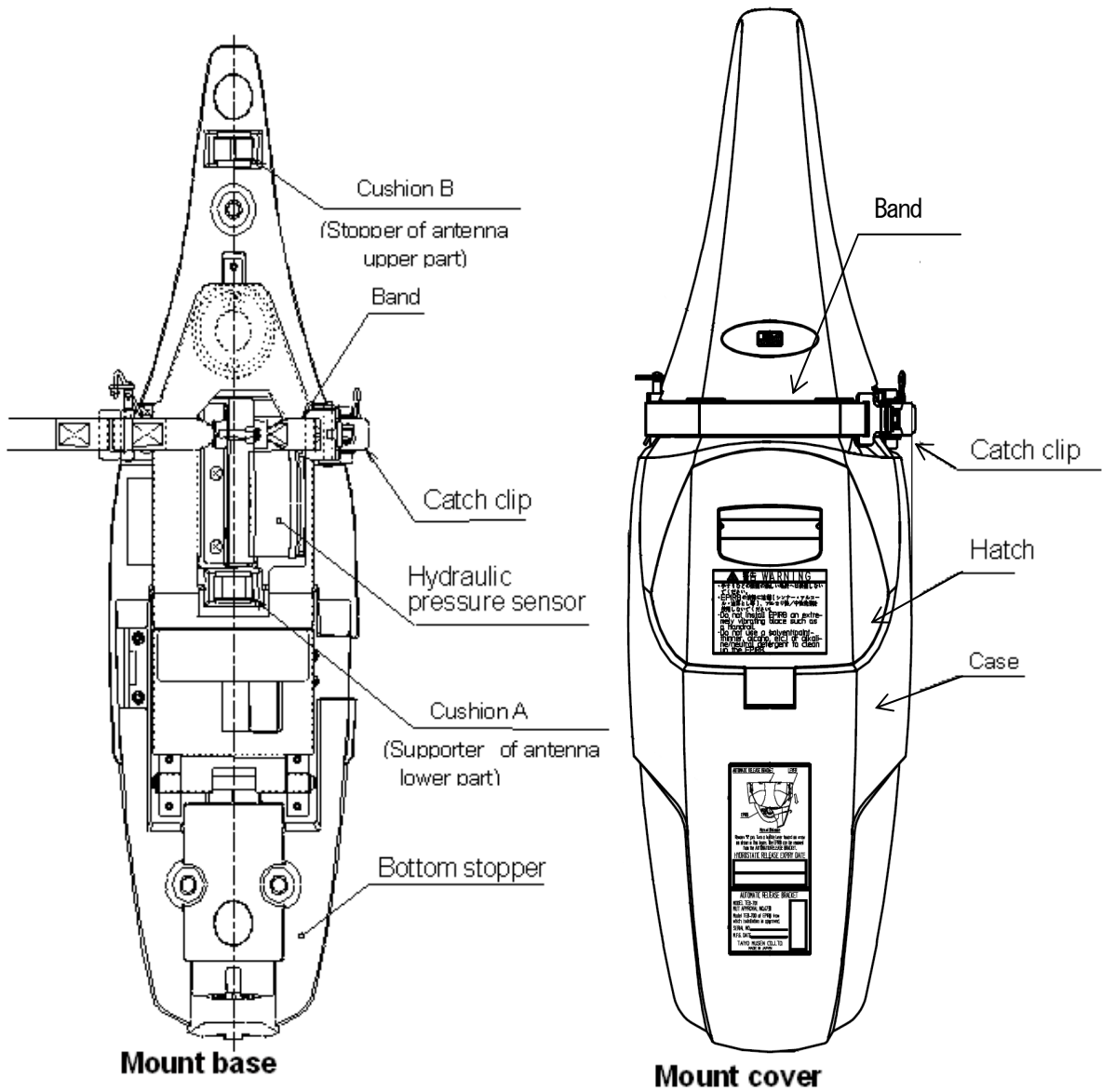

Fig.1-3-3 Automatic release bracket

CHAPTER 2. INSTALLATION

This unit must be installed by the dealer or service person.
Therefore, this chapter provides only general information related to the system.
For detailed information about the system, please refer to the Installation Manual.

NOTE

Refer the Installation manual for the detail of installation.

WARNING



The selector switch is set to "READY" position at factory.
Do not turn the selector switch to "ON" unless in case of emergency.

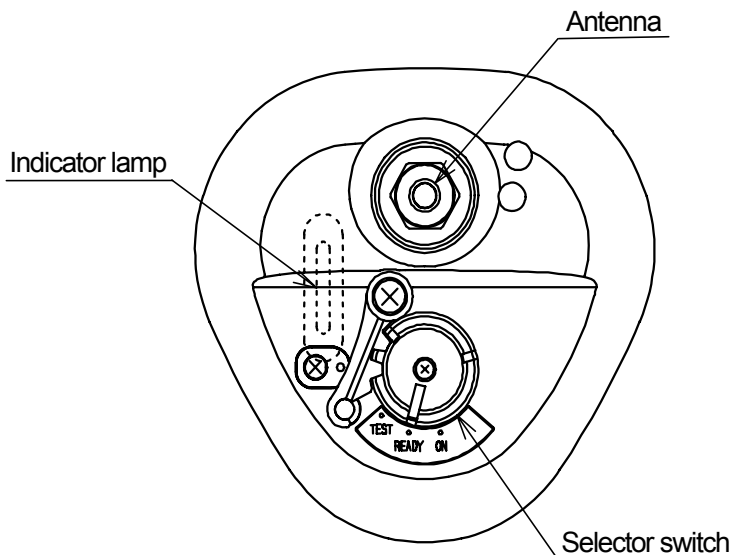

Fig.2 Selector switch



2-1 Checking of the components

After unpacking, check for all the components listed in Section 1-3 "Configuration".

2-2 Caution of installation

- (1) The Satellite EPIRB must be installed in a place where it is not directly exposed to waves and the automatic release bracket can smoothly be operated.
- (2) The Satellite EPIRB must be installed in a place where works and passing are not prevented and the Satellite EPIRB can easily be operated.
- (3) The Satellite EPIRB must be installed vertically.
- (4) The automatic release bracket contains a magnet. The magnetic compass and so forth must be put apart from the automatic release bracket 2 meters or more so that it is not influenced.
- (5) The Satellite EPIRB must be installed in a place where it is hard to be stolen.

WARNING

-  This unit may be damaged due to vibration. Do not absolutely install this unit in an extremely vibrating place such as a handrail.
-  This unit must not be installed in a place where a strong magnetic field is generated. The Satellite EPIRB may activate by the magnetic force.
-  The Satellite EPIRB must be installed apart from the compass and so for the 2 meters or more so that the magnetism is not influenced. The magnet in the automatic release bracket may affect the compass and so forth.

2-3 Outline of installation

Install the Satellite EPIRB main unit to the automatic release bracket confirming followings.

- (1) Selector switch is set to "READY" position.
- (2) Stopper pin is not broken.

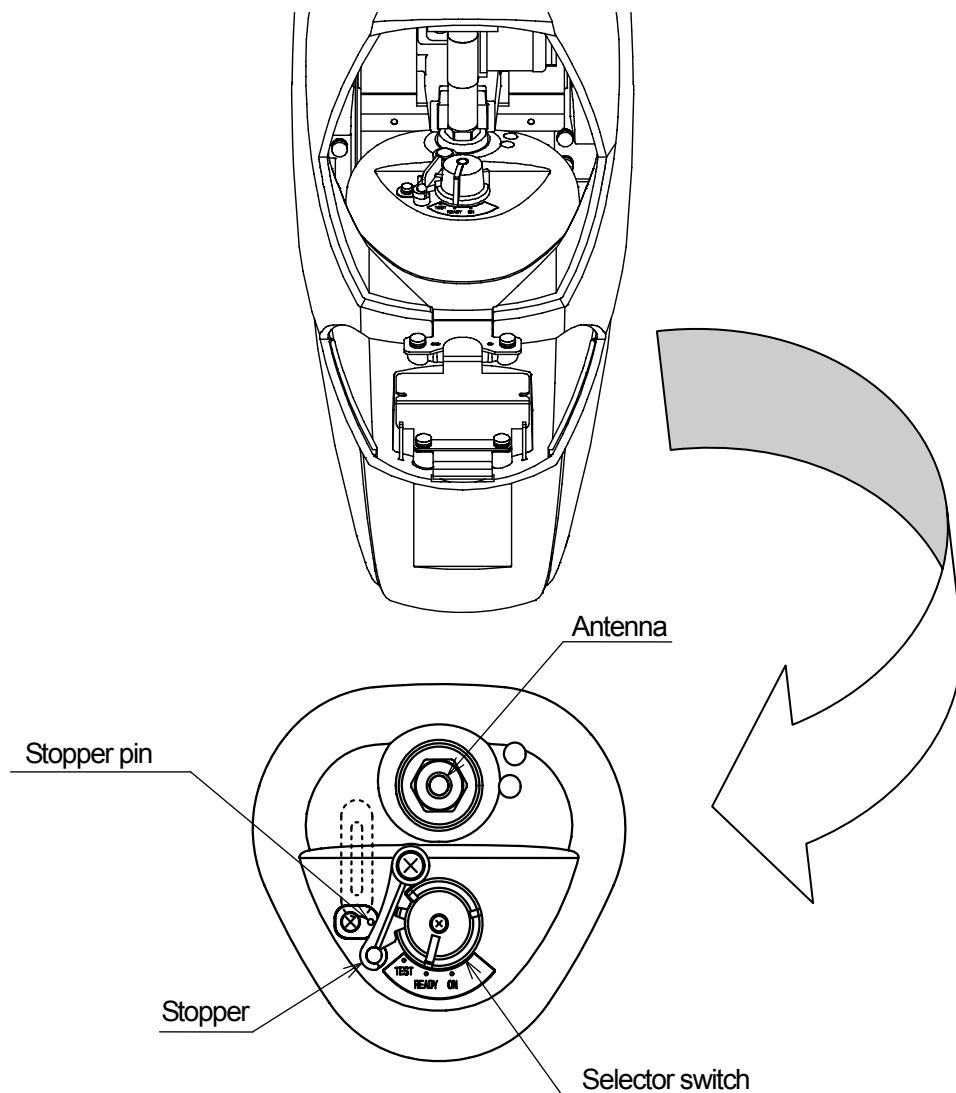

Fig.2-3 Satellite EPIRB main unit and automatic release bracket

3-1 Selector switch

The selector switch of this unit has following three positions.

(1) READY

Used to automatic activation. Distress signals are emitted immediately when the conductive switch senses water after the Satellite EPIRB main unit is released from the automatic release bracket. That is, the Satellite EPIRB main unit must float on the water surface to be able to emit distress signals.

(2) TEST

Used to check the functions of the Satellite EPIRB main unit. For details, see Section 3-6 "TEST".

(3) ON

Used to manual activation. Distress signals are emitted when turning the selector switch ON.



NOTE

Manual activation is not possible unless breaking the stopper pin.

Therefore, broken stopper pin is the evidence that the EPIRB had been once activated manually. In that case, replacing of the battery is required together with stopper pin.

NOTE

Release the stopper by breaking stopper pin to set the selector switch from READY to ON.

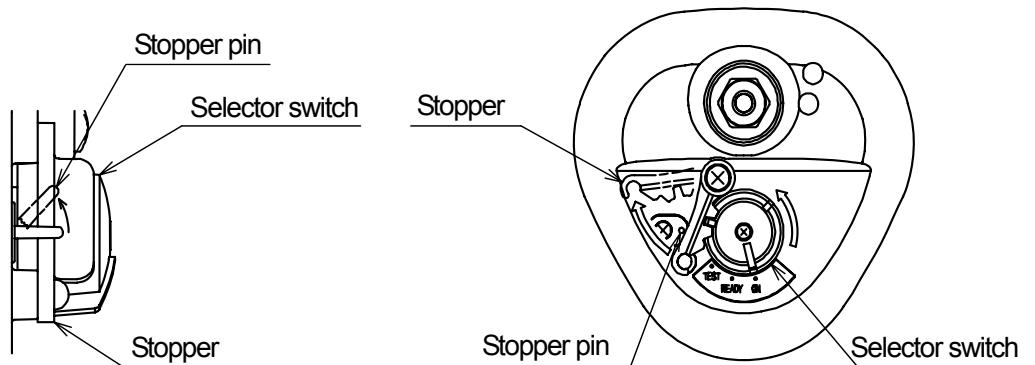

When broken stopper pin is found at periodical check, replacing of the battery must be required together with stopper pin as it is considered that the unit had been manually activated and the battery had been exhausted. The selector switch can be set to "TEST" without breaking the stopper pin.

Fig.3-1a Setting procedure of the Selector switch

Be sure to return the stopper to the original position after the selector switch was set.

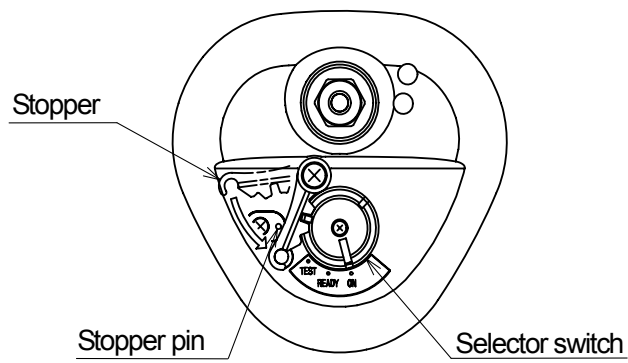

Fig.3-1b Reset of the Stopper

3-2 Power OFF

Confirm that the selector switch is set to "READY" (If not, set it to "READY"), and take the Satellite EPIRB out of water. Then the Satellite EPIRB stops its activation.

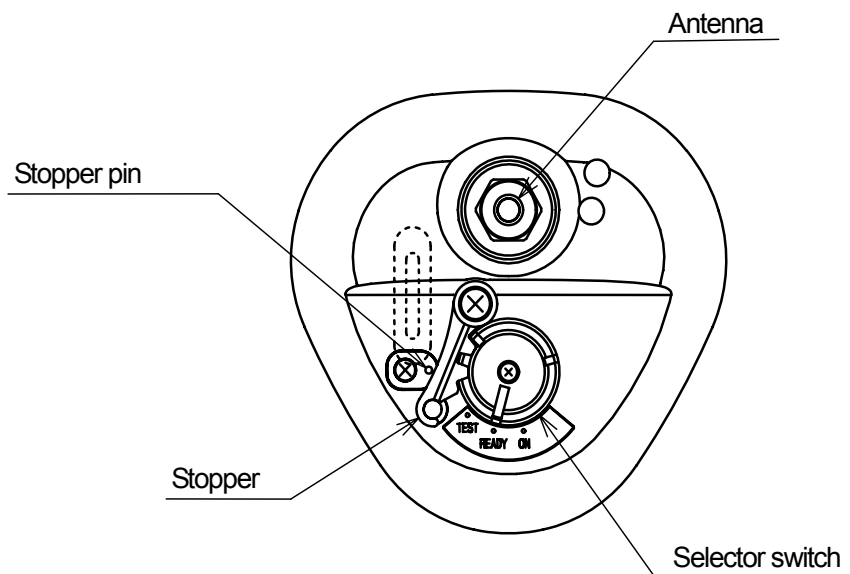

Fig.3-2 Power off

3-3 Manual activation

WARNING



Do not set the selector switch to "ON" except the case of manual activation in the emergency. Distress signals are emitted when turning the selector switch "ON".

If the selector switch is set to "ON", the Satellite EPIRB is activated, and it sends distress signals 50 seconds later regardless of its status.

When you activate the Satellite EPIRB manually, open the hatch of automatic release bracket, release the stopper by breaking the stopper pin, and set the selector switch to "ON".

To stop activation, set the selector switch to "READY", and take the Satellite EPIRB out of water if it is in the water.

Be sure to return the stopper to the original position after the selector switch was set.

At activation - selector switch "ON"

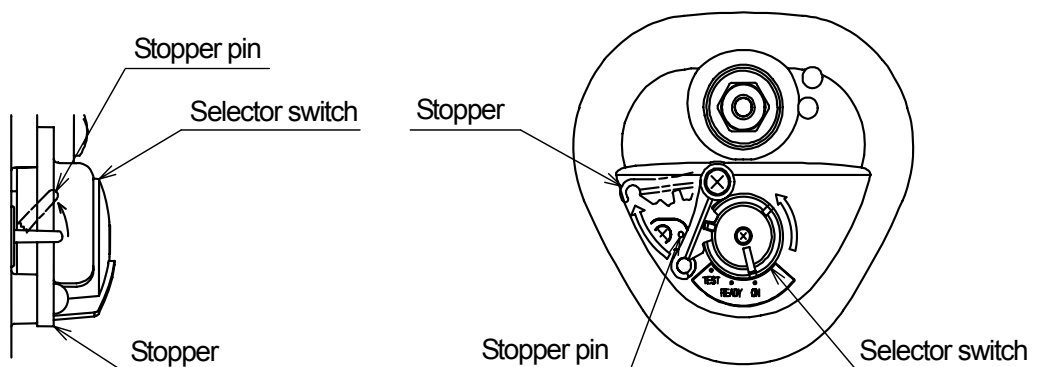

Fig.3-3a The status when Selector switch is turned to ON

Stop activation - selector switch "READY"

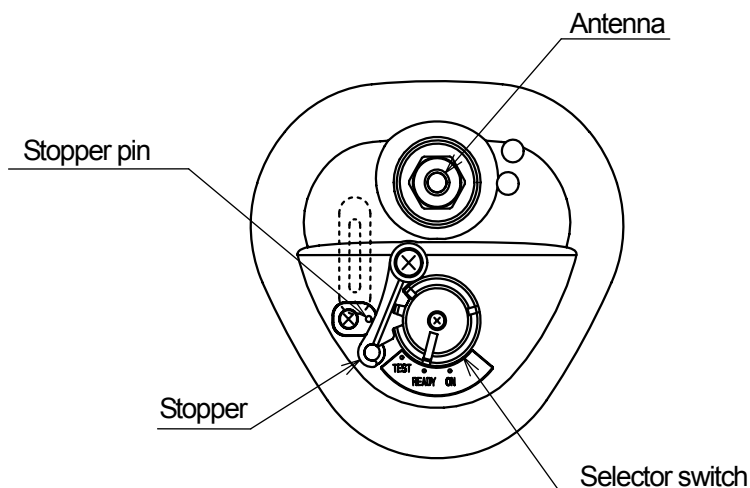

Fig.3-3b The status when Selector switch is turned to "READY"



CAUTION



Open slowly the cover of release bracket.

If you open faster, EPIRB main unit may deviate from release bracket and fall down.

NOTE

Manual activation is not possible unless breaking the stopper pin.

Therefore, broken stopper pin is the evidence that the EPIRB had been once activated manually. In that case, replacing of the battery is required together with stopper pin.

3-4 Automatic activation

If the ship sank as the selector switch is set to the READY position, the automatic release bracket releases the Satellite EPIRB main unit within water depth 4 m. The released Satellite EPIRB floats and senses the fact that it is floating on the water surface. The power is turned on automatically on the water, and the Satellite EPIRB starts to send distress signals 50 seconds later.



WARNING



If the Satellite EPIRB is taken out from water in distress, it stops sending distress signals.

Do not pull up the Satellite EPIRB from water during emergencies.



Once the hydraulic pressure sensor operates, it cannot be reused.

Be careful for Satellite EPIRB so as not to be stolen or not to be activated by mischief when the ship is in port.

3-5 Lanyard

The lanyard is used to tow the Satellite EPIRB by connecting with a float or survival boat.

WARNING



Never connect the lanyard to the automatic release bracket or ship body.
It disturbs the automatic release at emergency.

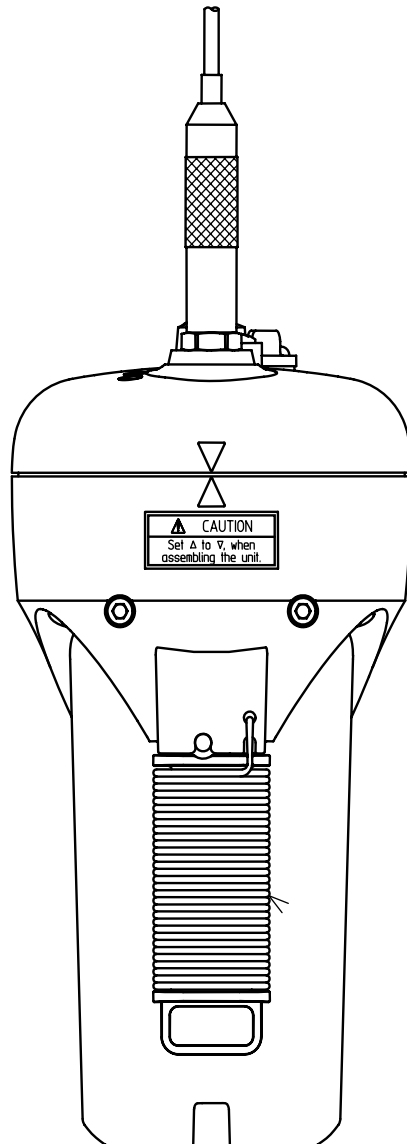

3

Fig.3-5 The lanyard

3-6 Test

This unit has the following test functions. It is recommended to perform this test once a week at the condition installed in bracket. Set the selector switch to “TEST” for performing this test. The selector switch can be turned to “TEST” without releasing the stopper.

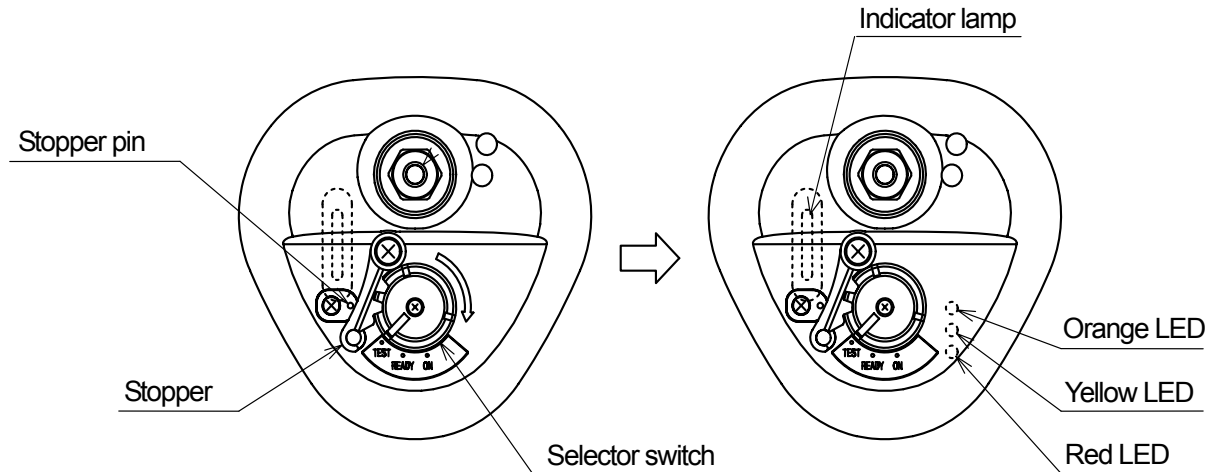

Fig.3-6 Position of the Selector switch when test is ongoing

Selector switch position	Test contents	Satellite EPIRB status	Test result	Action
TEST	Check the battery voltage *1	Yellow LED and orange LED light for 4 sec.	The battery voltage is normal.	-
		Yellow LED and orange LED blink for 4 sec. in 0.5 sec. interval.	The battery is somewhat consumed.	Contact purchased dealer or JRC
		Yellow LED and orange LED blink for 4 sec. in 0.1sec. interval.	The battery is exhausted.	Contact purchased dealer or JRC
	Emission check of 406.028MHz	Yellow LED and red LED light for 0.44 sec.	406.028MHz transmitter is normal.	-
		Yellow LED lights for 0.44 sec. (Red LED does not light.)	The signal is not transmitted though the SYNTH circuit works.	Contact purchased dealer or JRC
		LED does not light at all.	Malfunction of the transmitter.	Contact purchased dealer or JRC
	Check the Indicator lamp	Indicator lamp flashes at 2.6 sec. Interval.	The indicator lamp is normal.	-
Indicator lamp does not flash.		Malfunction of the indicator lamp.	Contact purchased dealer or JRC	
READY	-	-	-	-

Satellite EPIRB is in the normal status when results of above tests are normal.

*1 Voltage of the battery varies by temperature.

Especially, the voltage decrease is remarkable at the low temperature. At the low temperature, LED might blink even if the battery voltage is normal.

This test result is effective at the ambient temperature $23^{\circ}\text{C} \pm 5^{\circ}\text{C}$.

NOTE

Power consumption by performing this test is very little.

Even if performing this test every week until expiry date of the battery, the Satellite EPIRB still possible to transmit the distress signal over 48 hours.

If an error is detected by this test or the effective periods of the battery and hydraulic pressure sensor expired, contact the purchasing dealer, JRC agent or one of the JRC branches.



WARNING



The battery and hydraulic pressure sensor which expired effective periods must not absolutely be used. If such battery and sensor are used, the distress signal may not be emitted at the emergency disaster. Take care that their lives do not expire.



CAUTION



In this test, permitted distress signal for the test purpose is transmitted only by one burst. Do not execute the test repeatedly in a short time frame.



Execute the test in 00 - 05 minutes of each o'clock for the reduction of processing capacity in the satellite.



This test must not be performed, as the Satellite EPIRB main unit remains removed from the automatic release bracket. The distress signal may erroneously be emitted.



If you want to replace or repair the battery or hydraulic pressure sensor, contact the purchasing dealer, JRC agent or one of the JRC branches.

3-7 Mounting of the Satellite EPIRB main unit into automatic release bracket

Mount the Satellite EPIRB main unit into the automatic release bracket, in accordance with the following procedure.

- (1) Set the band on the mount base of the automatic release bracket.

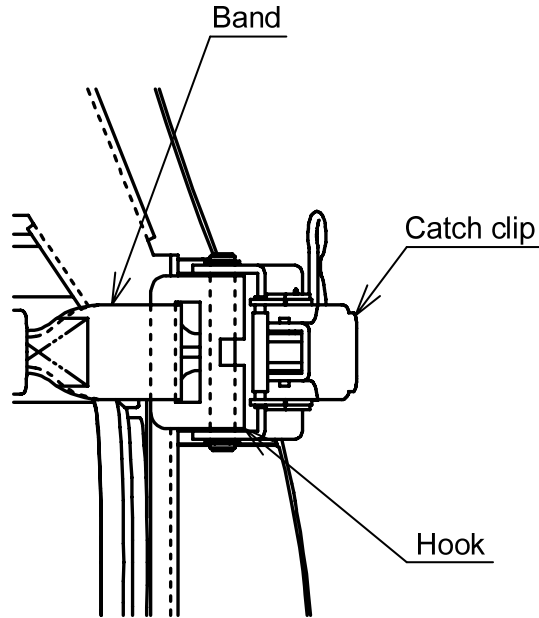

Fig.3-7a Mounting band to automatic release bracket (1)

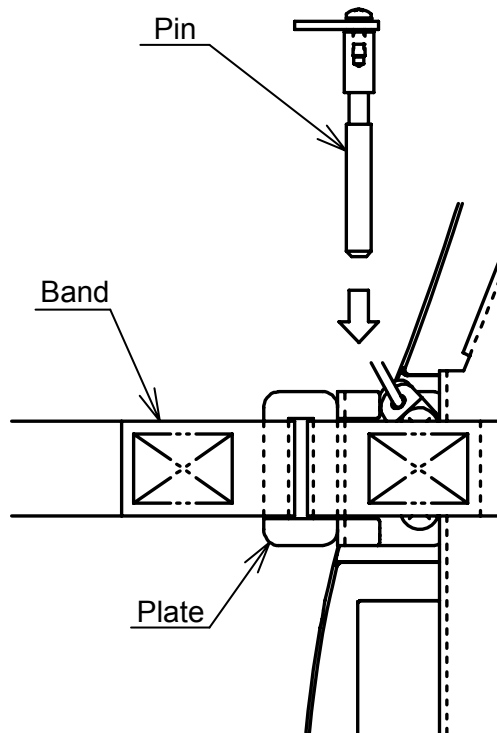

Fig.3-7b Mounting band to automatic release bracket (2)

(2) Then, put the Satellite EPIRB main unit on the mount base.

- 1) Fit the bottom of the Satellite EPIRB main unit on the bottom stopper of the mount base of automatic release bracket.

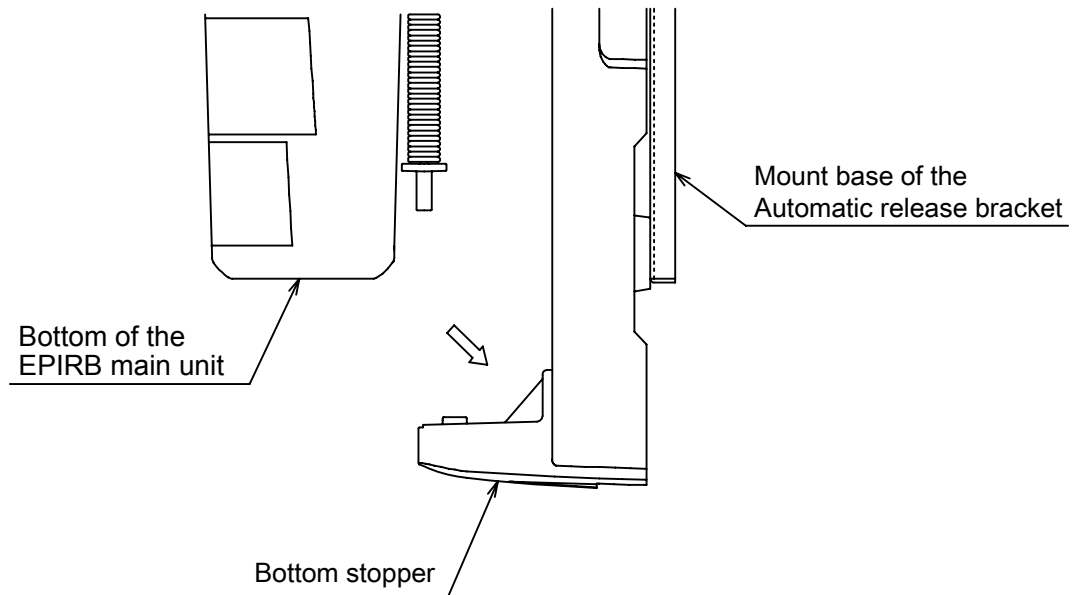

Fig.3-7c Installation of Satellite EPIRB main unit into automatic release bracket

- 2) Fit the bottom of antenna on cushion A.

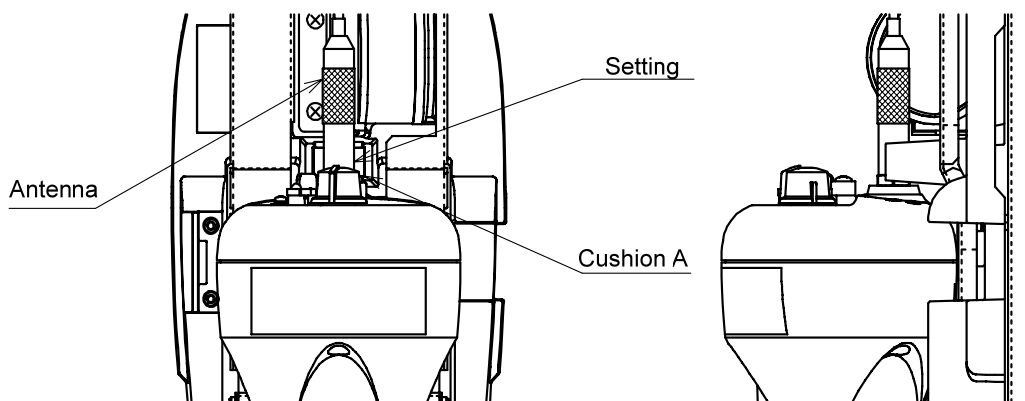

Fig.3-7d Mounting antenna to cushion A

3) Insert the top of antenna on cushion B

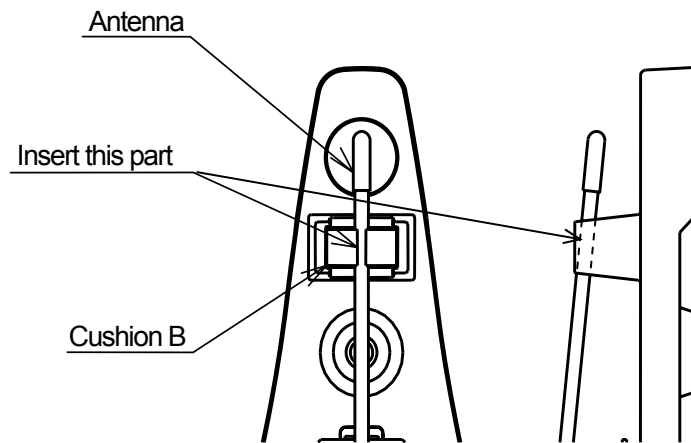

Fig.3-7e Mounting antenna to cushion B

- (3) Put the mount cover on the mount base from bottom side, and fasten the belt over the mount cover to do not bend, and fasten with catch clip. Then, insert the lock pin to the catch clip. The hydraulic pressure sensor is made of resin, and it may be damaged by excessive impact or stress. Be careful not to give too much impact or stress to it.

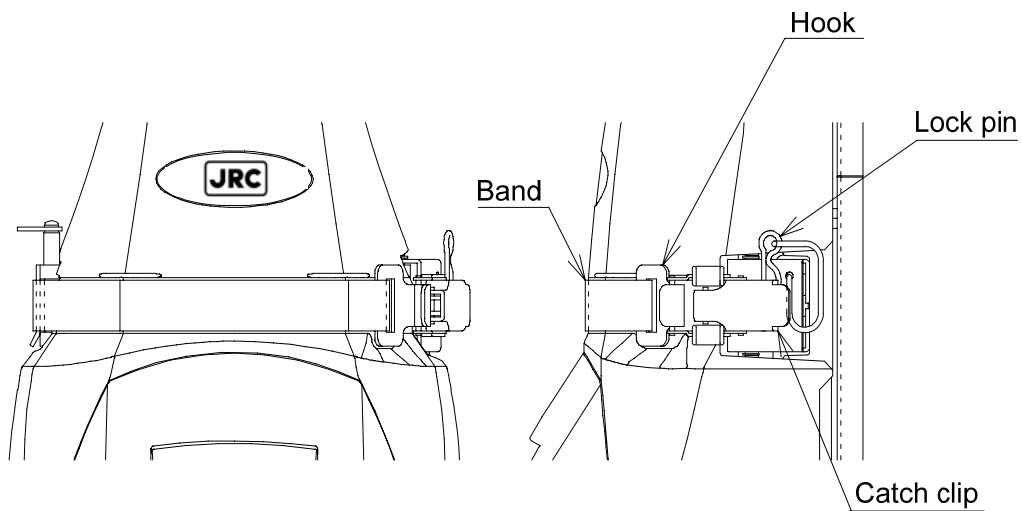

Fig.3-7f Fixing Catch clip

- (4) Open the hatch, and confirm following things. Be sure to shut the hatch after confirmed those.
- Selector switch is set to "READY".
 - Stopper is set tightly.
 - Stopper pin is not broken.

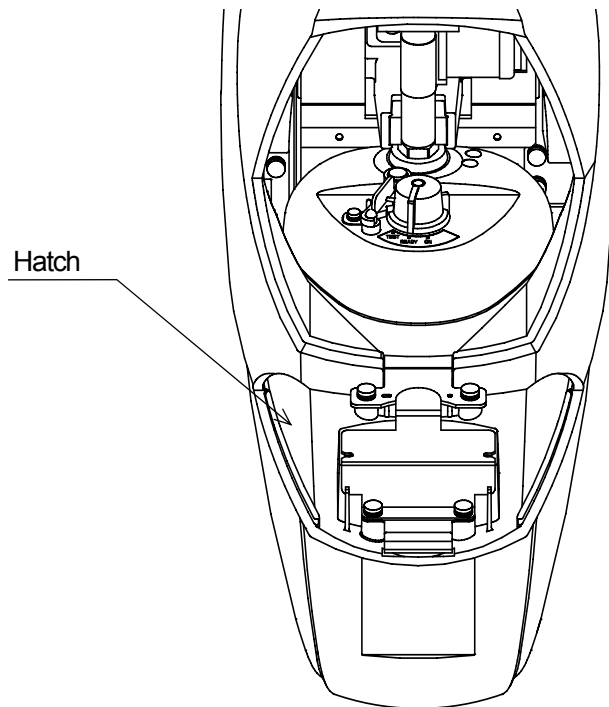

Fig.3-7g Confirmation after mounting

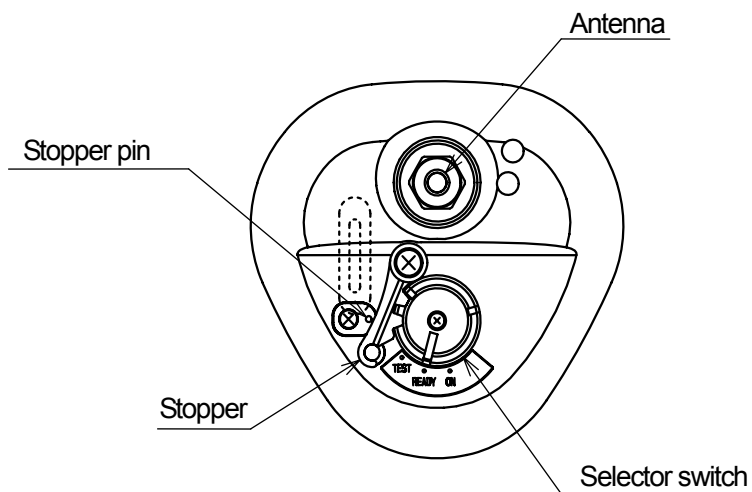

Fig.3-7h Confirmation of automatic release bracket (inside)



WARNING



Mount the Satellite EPIRB main unit on the automatic release bracket properly.

Improper mounting causes the Satellite EPIRB not to be automatically released from the bracket in an emergency.

3-8 Removal of Satellite EPIRB main unit from automatic release bracket

Remove the Satellite EPIRB main unit from the automatic release bracket by reverse order of procedure in CHAPTER 3-7, (2) to (4).

4-1 Implementation

The selector switch must be set to the "READY" position while sailing.

 **WARNING**



The selector switch must be set to the "READY" position while sailing.

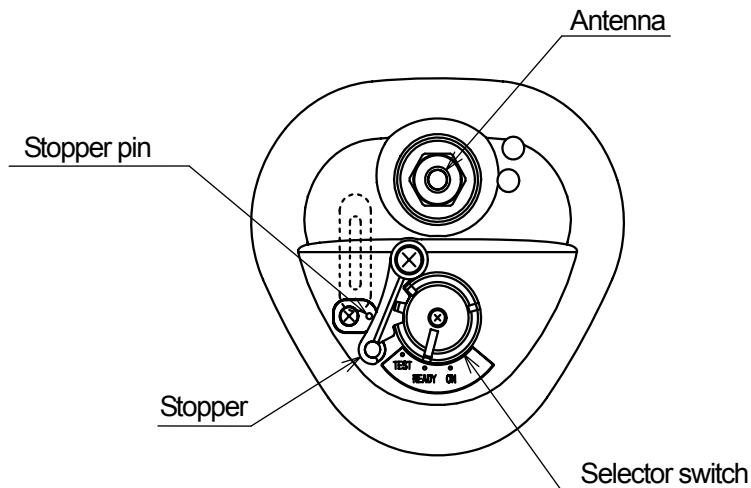

Fig.4-1 Confirmation of Selector switch position



If the ship sank as the selector switch is set to the READY position, the automatic release bracket releases the Satellite EPIRB main unit within water depth 4 m. The released Satellite EPIRB floats and senses the fact that it is floating on the water surface. The power is turned on automatically on the water, and the Satellite EPIRB starts to send distress signals 50 seconds later.

 **WARNING**



Once the hydraulic pressure sensor operates, it cannot be reused.

Be careful for Satellite EPIRB so as not to be stolen or not to be activated by mischief when the ship is in port.

NOTE

The lanyard is used to tow the Satellite EPIRB by connecting with a float or survival boat.

Please refer to page ix "OPERATION AT EMERGENCY" for the operation of the Satellite EPIRB at distress.

4-2 Maintenance

For details of maintenance, refer to the Installation Manual. This chapter describes the simple procedure for routine maintenance which you should follow on board the ship every day to maintain the system in a good condition.

If any abnormality is found, or it is necessary to replace the battery or hydraulic pressure sensor, contact the purchasing dealer, JRC agent or one of the JRC branches .

Check item	Action
(1) Is the selector switch set to READY?	(1) Confirm whether the selector switch is fixed to the READY position with the stopper.
(2) Is not the stopper pin broken?	(2) Replace the stopper pin and battery. Ask us or our dealer for the replacement. (Broken stopper pin shows that the Satellite EPIRB had been manually activated and the battery is exhausted.)
(3) Is the unit in the floatable state?	(3) Do not put something on the Satellite EPIRB, and do not bind the Satellite EPIRB. Too much icing must be eliminated so that the antenna, selector switch, indicator lamp, and hydraulic pressure sensor are not damaged.
(4) Are the catch clip and lock pin of the automatic release bracket fastened?	(4) Tightly fasten if they are loosened.
(5) Is the automatic release bracket firmly installed?	(5) Fasten the screws which are fixing the automatic release bracket to the ship body if they are loosened.
(6) Isn't there any deformation or damage on the main unit and automatic release bracket?	(6) Contact the purchased dealer, JRC agent or one of the JRC branches if there is any deformation or damage on those.
(7) Aren't the accessories such as the lanyard, antenna, usage labels etc. damaged or missing?	(7) Contact the purchased dealer, JRC agent or one of the JRC branches if they are damaged or missing.
(8) Did not the battery expire?	(8) Pay attention to the battery effective period indicated on the label. Contact the purchased dealer, JRC agent or one of the JRC branches if it expired.
(9) Did not the hydraulic pressure sensor effective period expire?	(9) Pay attention to the hydraulic pressure sensor effective period. Contact the purchased dealer, JRC agent or one of the JRC branches when its expiry date approaches.
(10) Is not the Satellite EPIRB installed in the place where the vibration is extreme?	(10) Excessive vibration will damage the Satellite EPIRB and automatic release bracket. Contact the purchased dealer, JRC agent or one of the JRC branches to change the installation place if the Satellite EPIRB is installed in the place where the vibration is extreme.

The metallic part of the automatic release bracket is made of stainless steel.

Its surface may rust by adhesion of iron powders, but extent of the corrosion will be little to do not affect the mechanical intensity under the ordinary use.

4-3 Periodical cleaning of conductive switch terminal

(1) Importance of periodical cleaning

This Satellite EPIRB transmits distress signal after detecting water when it is activated by automatic release.

Although the Satellite EPIRB is stored in a case (automatic release bracket), small dust may invade into the case and adhere on the conductive switch terminal as the automatic release bracket is not water-tight structure. The Satellite EPIRB may not be activated properly when oily dust adhered on its conductive switch terminal.

WARNING



The Satellite EPIRB may not transmit the distress signal even if it is on the water when the conductive switch terminal is smeared by oily dust. Perform periodical cleaning of the Satellite EPIRB in accordance with the procedure described below.



The distress signal may transmit by removing the Satellite EPIRB main unit from the automatic release bracket when the conductive switch terminals are covered by wet salt. Perform periodical cleaning of the Satellite EPIRB in accordance with the procedure described below.

(2) Cleaning procedure

The conductive switch terminal and its surrounding, and the side of Satellite EPIRB main unit should always be kept clean so that the Satellite EPIRB can be activated properly. Please perform following periodical cleaning about once a month.

- 1) Confirm that the Satellite EPIRB main unit is not wet, and the selector switch is set to "READY".
- 2) Remove the Satellite EPIRB main unit from the automatic release bracket.
- 3) Wipe the side of Satellite EPIRB main unit carefully by using soft cloth wet with the fresh water and squeezed hard. Be sure to wipe the two conductive switch terminal one by one.

If the Satellite EPIRB starts to transmit the distress signal during the cleaning by any mistake, re-install the Satellite EPIRB main unit to the automatic release bracket immediately (within 50 sec. after transmission started) to stop the transmission.

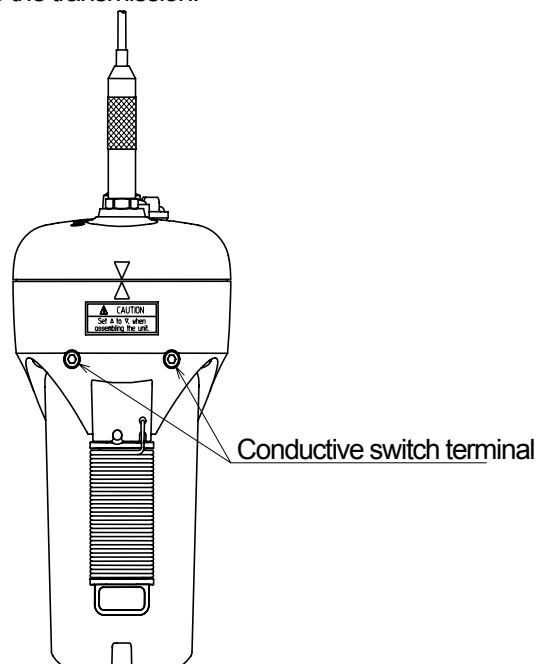

Fig.4-3a Conductive switch terminal

CAUTION



Do not wipe the both of conductive switch terminals in the same time.
It might cause the false transmission of distress signal due to the sensor detects the water and activated.



Do not use salt water to wipe the Satellite EPIRB. Using salt water may cause false transmission of the distress signal by adhering salt on the conductive switch terminals.



Do not loosen the conductive switch terminal.

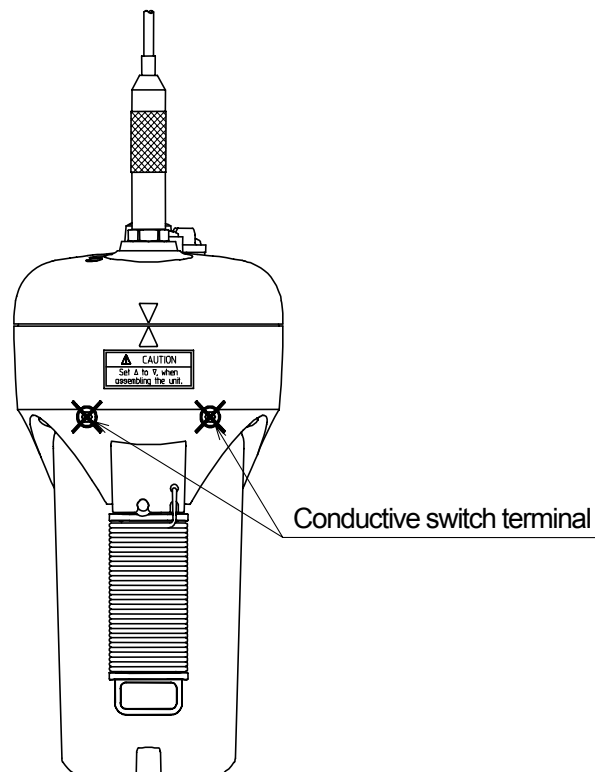

Fig.4-3b Conductive switch terminal

- 4) Visually confirm that the Satellite EPIRB main unit is clean enough, then re-install the Satellite EPIRB main unit to the automatic release bracket.

Please perform the above mentioned cleaning about once per month.

4-4 Test

This unit has the following test functions. Please refer section 3-6 "Test" for the details.

CAUTION



In this test, permitted distress signal for the test purpose is transmitted only by one burst. Do not execute the test repeatedly in a short time frame.



Execute the test in 00 - 05 minutes of each o'clock for the reduction of processing capacity in the satellite.



This test must not be performed as the Satellite EPIRB main unit remains removed from the automatic release bracket. The distress signal may erroneously be emitted.

4-5 Parts for periodical replacement

This Satellite EPIRB has the following parts to be replaced periodically.
If the replacement period approaches, contact us or our dealer.

Table 4-5 Parts for periodical replacement

Parts to be replaced	Replacement period
(1) Battery replacement set a) Battery b) O-ring (2 kinds) c) Protection seal	5 years after installation (Described on the label)
(2) Hydraulic pressure sensor	2 years after installation (Described on the hydraulic pressure sensor)
(3) Stopper pin	After manual activation (Replace the exhausted battery together)

NOTE

Please note that the replacement time of the battery-replacement-set and the hydraulic pressure sensor is not always corresponding.

4-6 Cleaning of Satellite EPIRB main unit

The main body of Satellite EPIRB is made of the resin such as polycarbonates.

Solvents and alkaline detergents affects the resin material.

Please pay attention to followings when the maintenance/cleaning of ship's hull or onboard equipments.

CAUTION



Do not use a solvent (paint-thinner, alcohol etc.) or alkaline/neutral detergent to clean up the body of Satellite EPIRB.

It causes crack on the resin if such a detergent is used, and Satellite EPIRB may not operate properly in the worst case by leaking etc.

- (1) Use soft cloth wet with the warm fresh water to wipe the body of Satellite EPIRB main unit.
- (2) Do not write letters etc. with an oily pen on the body of Satellite EPIRB since the solvent contained in the oily pen affects the body.
- (3) Cover the Satellite EPIRB with vinyl cloth to protect from spray of paints when re-painting the ship's hull for maintenance.
- (4) Detach the Satellite EPIRB (together with automatic release bracket) from the ship's wall at the cleaning of ship's hull with a high-pressure washing machine so that the washing liquid does not splash on the Satellite EPIRB directly or indirectly.
- (5) Contact the purchasing dealer, JRC agent or one of the JRC branches immediately for repair when you found a crack on the body of Satellite EPIRB.

4-7 After service

4-7-1 Longevity /exchange time of Satellite EPIRB

The longevity of Satellite EPIRB is approximately 7years (exchange it for the new article every seven years.)

Satellite EPIRB automatically releases from ship and floats on the sea surface when the ship sank, and has the function to transmit the distress signal to inform the accident position. Therefore, the Satellite EPIRB is generally installed on the deck etc. where the obstacle to avoid smooth floating is few. Deterioration in the performance is not avoided in many years even if the periodical maintenance is performed because the Satellite EPIRB is exposed to wind and rain, waves, and direct sunshine in this place.

A part of the function of the Satellite EPIRB may be restored by exchanging parts, but exchange of parts may cost a large sum. Especially, when quality of the case is changed by weathering and slightly cracked, it causes the malfunction because of the invasion of water though the case uses a plastic system material with weather resistance. It costs a large sum to exchange this one.

In case of the Satellite EPIRB that has passed over seven years after installation, replacing to new Satellite EPIRB is much practical than keeping maintenance when cost and reliability are considered.

Therefore, the replacement of Satellite EPIRB would be recommended at its periodical maintenance for the EPIRB which passed nearly seven years after installation. Please understand the Satellite EPIRB is for safety product, and we recommend to replace it ahead of time for the new article.

4-7-2 How to discard the Satellite EPIRB

Satellite EPIRB is the device to inform the location of the vessel in distress by transmitting ID code signal of the vessel. If the signal is emitted by Satellite EPIRB except for emergency purpose, it causes serious confusion for search and rescue operation. In addition, if the Satellite EPIRB is installed on the vessel, the owner of the vessel will receive strict warning from the organization which manages the search and rescue operation for marine vessel. For this reason, it is strictly prohibited to emit the unnecessary signal from Satellite EPIRB, even accidental emission. It is also prohibited to emit the signal from unused EPIRB wherever it stores.

When the Satellite EPIRB is not necessary for the vessel due to the reason of scrapping or selling vessel, and/or changing to new Satellite EPIRB, contact the purchasing dealer, JRC agent or one of JRC branches, and ask them to take necessary procedure for disposal as mentioned below.

- (1) To avoid accidental emission, fix the switch position of Satellite EPIRB to "READY" with stopper and install the Satellite EPIRB to its automatic release mounting bracket. In case of removing the Satellite EPIRB from the automatic release mounting bracket, pack it not to get wet by water. Then, ask the the purchasing dealer, JRC agent or one of the JRC branches to remove the battery from the Satellite EPIRB.
- (2) Submit the document for the abandonment of Satellite EPIRB or for the change of Satellite EPIRB to the managing organization, following to the regulation concerning to Satellite EPIRB.
- (3) Contact the purchasing dealer, JRC agent or one of the JRC branches and notify the name of the vessel and serial number of the Satellite EPIRB to be abandoned.
- (4) Follow the local regulation in case of disposal.



⁷WARNING



Request abandonment to a service shop, manufacturer or its dealer for the disused Satellite EPIRB.

There is a possibility that the emergency beacon is transmitted from disused Satellite EPIRB when it is disposed improperly. If the emergency beacon is transmitted by improper disposal, large confusion is caused in search and rescue operations.



Do not make the used battery to short-circuit, discharging electricity compulsorily or using for other usages. Send used batteries to the purchasing dealer, JRC agent or one of the JRC branches.



Do not discard used batteries. Send used batteries to the purchasing dealer, JRC agent or one of the JRC branches, to avoid causing environmental problem by throwing them away.

Note (1): The any necessary cost to dispose or to change Satellite EPIRB, including the document submitting fee, the cost returning Satellite EPIRB to agent/manufacturer should be taken care of by the user.

(2): Please acknowledge that the battery disposal cost and carriage become charged.

4-7-3 Necessary procedure for Satellite EPIRB installed in the vessel to be resold

In case of that Japanese flag vessel is resold to Japanese client and new owner succeeds in the radio station license.

(Contact the purchasing dealer, JRC agent or one of the JRC branches, and ask them to take necessary procedure and work as mentioned below.)

- (1) To avoid accidental emission, make sure that the switch position of Satellite EPIRB is set to “READY”, that the switch is fixed by the stopper, and that the Satellite EPIRB main unit does not get wet. Then, store the proper place until new ID code is available.
- (2) Submit the necessary document for the continuous usage of radio station license concerning to Satellite EPIRB to the managing organization, following to the Japanese regulation.
- (3) When the document is approved, make sure MMSI protocol and rewrite ID code and the name of vessel to new one and then, install the Satellite EPIRB on proper place referring to the manual.

In case of that Japanese flag vessel is resold to Japanese client and new owner does not succeed in the radio station license.

(Contact the purchasing dealer, JRC agent or one of the JRC branches, and ask them to take necessary procedure and work as mentioned below.)

- (1) To avoid accidental emission, make sure that the switch position of Satellite EPIRB is set to “READY”, that the switch is fixed by the stopper, and that the EPIRB main unit does not get wet. Then, store the Proper place until it is disposed.
- (2) Submit the necessary document for the abandonment of radio station license concerning to Satellite EPIRB to the managing organization, following to the Japanese regulation.
- (3) Contact the purchasing dealer, JRC agent or one of the JRC branches, and ask them to take necessary procedure and work for the disposal of the Satellite EPIRB.

In case of that Japanese flag vessel is resold to overseas (outside of Japan) client.

(Contact the agent, the dealer, the service shop or the manufacturer which supplied the Satellite EPIRB, and ask them to take necessary procedure and work as mentioned below.)

- (1) To avoid accidental emission, make sure that the switch position of Satellite EPIRB is set to “READY”, that the switch is fixed by the stopper, and that the Satellite EPIRB main unit does not get wet. Then, store the proper place until new ID code is available.
- (2) Submit the necessary document for the continuous usage of radio station license concerning to Satellite EPIRB to the managing organization, following to the Japanese regulation.
- (3) Make sure if the EPIRB has the effective type approval at new nationality, or if the Satellite EPIRB is permitted for usage without effective type approval at new nationality. The Satellite EPIRB installed in Japanese flag vessel has HK type approval.
- (4) Confirm that whether the explanation displayed in Satellite EPIRB main body is written in English or not (ask the disposal to purchasing dealer, JRC agent or one of the JRC branches when the Satellite EPIRB

displays Japanese sign only, because it cannot be equipped with foreign flag vessel).

- (5) If the continuous usage of Satellite EPIRB is not permitted, contact the dealer, the service shop or the manufacturer, and ask them for the abandonment of the Satellite EPIRB.
- (6) If it is permitted to use the Satellite EPIRB continuously in the same vessel, request new owner to submit the information about MMSI at new nationality and new vessel name with a formal document. Then, contact the dealer, the service shop or the manufacturer, and ask them for rewriting the data in the EPIRB.
- (7) Rewrite the vessel name and MMSI to those which are registered by new owner.
- (8) Install the Satellite EPIRB on proper place referring to the manual.

NOTE

Write the new MMSI in the main body of Satellite EPIRB, when the MMSI is newly delivered.

WARNING



Ask the procedures (submitting continuous usage or abandonment of radio station license, and confirmation of continuous usage of Satellite EPIRB) and works (returning or abandonment of equipment, rewriting MMSI of inner main body, and installation to the new ship) to purchasing dealer, JRC agent or one of the JRC branches (refer to CHAPTER 4-7, After Service)

If these procedures and works are not executed, false transmission or wrong ID code signal might be emitted in distress, and it causes serious confusion for search and rescue operation. Also the owner of the vessel will receive strict warning from the organization that manages the search and rescue operation for marine vessel.



When an existing Satellite EPIRB is resold to another ship, the MMSI and ship name of the Satellite EPIRB must be changed. It sometimes happens that the MMSI and ship name of Satellite EPIRB is not changed as following reasons.

New ship name is undecided yet.

New MMSI cannot be acquired.

Ship's dealer is taking necessary procedures.

New MMSI is not acquired yet, but Satellite EPIRB is included in the sales contract of the used vessel.



When the ship meets disaster, a large trouble will be given to the search rescue organization when ship information on Satellite EPIRB is wrong.

Remove the Satellite EPIRB if MMSI/new ship name cannot be renewed.



It is strongly prohibited to install old ID's Satellite EPIRB removing its battery only.

5-1 Electrical specifications

A) General specifications

A-(1) Main unit

Water-proof	When the Satellite EPIRB is left in the water at 10m depth for five minutes, no abnormality arises to Satellite EPIRB.								
Operation temperature	-20°C to +55°C								
Vibration	Set the Satellite EPIRB on a vibration tester, and apply the following vibration to the direction of up and down, right and left, and back and forth for fifteen minutes each. (The sweep rate must be 1 octave/minute or less.) <table style="margin-left: auto; margin-right: auto;"> <tr> <td>Frequency</td> <td>Total amplitude</td> </tr> <tr> <td>0 to 12.5 Hz</td> <td>3.20 mm</td> </tr> <tr> <td>12.5 to 25 Hz</td> <td>0.76 mm</td> </tr> <tr> <td>25 to 50 Hz</td> <td>0.20 mm</td> </tr> </table>	Frequency	Total amplitude	0 to 12.5 Hz	3.20 mm	12.5 to 25 Hz	0.76 mm	25 to 50 Hz	0.20 mm
Frequency	Total amplitude								
0 to 12.5 Hz	3.20 mm								
12.5 to 25 Hz	0.76 mm								
25 to 50 Hz	0.20 mm								
Impact	Let the Satellite EPIRB freely drop from a height of 20m onto a water surface twice.								
Weight and dimension	120(W) x 529mm(H) x 116(D) mm, Approx. 1.3 kg								
Casing material / color	SAS resin / orange (8.5R 5.5/11.0)								
Indicator lamp	Xenon lamp Luminous intensity : 0.75 cd or more								
Transmission	48 hours or more								



A-(2) Automatic release bracket

Release method of Satellite EPIRB	Water pressure detection
Method of fixing case	Band
Release depth	1.5 m to 4.0 m
Operation temperature	-20°C to +55°C
Dimension	175(W) x 585(H) x 175(D) mm
Weight	Approx. 2.9 kg
Validity period of Hydraulic pressure sensor	2 years after installation

B) Electrical specifications

B-(1) 406 MHz

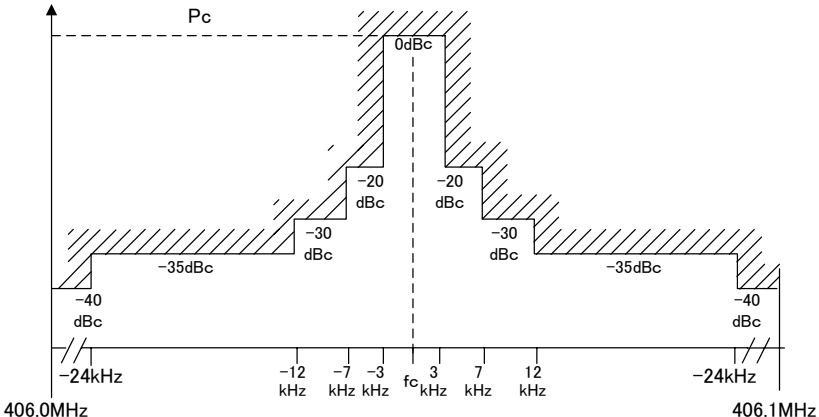
Long-time stability	406.028 MHz (within +2 kHz, -5 kHz)
Frequency stability	Short term : Less than $2 \times 10^{-9}/100$ ms Medium term Mean slope : Less than $\pm 1 \times 10^{-9}/\text{min}$. Residual frequency variation : Less than 3×10^{-9}
Output power	Less than 5 W ± 2 dB
Transmitting spurious	Intensity of unwanted radiation during modification is shown below. 
Data encoding	Bi-phase L
Modulation method	Phase modulation (PSK : G1B)
Phase deviation	$\pm 1.1 \pm 0.1$ radian (peak value)
Rise in modulation	50 μ s to 250 μ s
Antenna polarization	Linear polarization
Antenna gain	-3 dBi to 4 dBi Elevation angle : $5^\circ < \theta < 60^\circ$
VSWR	1.5 or less
Impedance	50 Ω

B-(2) Digital message

Repetition time of transmission	47.5 to 52.5 sec. (random)
Transmission time	440 ms $\pm 1\%$ (short message)
Digital message	As setting
Bit rate	400 bps $\pm 1\%$
Bit synchronization	All 15 bits are "1"
Synchronization frame	000101111

B-(3) Homing signal

Transmitting frequency	121.5 MHz \pm 6.075 kHz
Peak radiation power	50 mW \pm 3 dB
Modulation	AM
Modulation frequency	300 Hz to 1600 Hz
Modulation repetition cycle	2 Hz to 4 Hz

B-4) Battery

Model	Model P-35
Type	Lithium Manganese dioxide pack
Composition	Serial 3 cells
Voltage	Nominal 8.4 V
Capacity	10.4 Ah
Validity period	5 years after installation

B-(5) Activation

Automatic	The Satellite EPIRB starts to transmit the distress signal upon detection of water after release of Satellite EPIRB from the automatic release bracket.
Manual	The Satellite EPIRB starts to transmit the distress signal by turning selector switch to "ON".



CHAPTER 6. JRC SERVICE NETWORK

Please contact the dealer from which you purchased the device or our marketing offices that is nearest to you for any question as to the after-sales service (See back cover).

Please refer to the back of the book for more information.



JRC Tokyo <http://www.jrc.co.jp>

JRC Seattle <http://www.jrcamerica.com>

Alphatron <http://www.alphatronmarine.com>

アスベストは使用していません
Not use the asbestos

CODE No.7ZPSC0215A

For further information, contact:

JRC *Japan Radio Co., Ltd.*
Since 1915

URL <http://www.jrc.co.jp>

Marine Service Department

Telephone : +81-3-3492-1305

Facsimile : +81-3-3779-1420

e-mail : tmisc@jrc.co.jp

SEATTLE Branch

Telephone : +1-206-654-5644

Facsimile : +1-206-654-7030

e-mail : marineservice@jrcamerica.com

ALPHATRON

Alphatron Marine BV

URL <http://www.alphatronmarine.com>

Rotterdam (Head office)

Alphatron Marine B.V.

Telephone : +31 (0)10- 453 4000

Facsimile : +31 (0)10- 452 9214

e-mail : service@alphatronmarine.com

Singapore Branch

Alphatron Marine Systems Pte Ltd

Telephone : +65 6863 0335

Facsimile : +65 6863 3305

e-mail : service@alphatronmarinesystems.com