



Programming Reference

For printer model:

HR2 Series



Copyrights

Any unauthorized reproduction of the contents of this document, in part or whole, is strictly prohibited.

Limitation of Liability

SATO Corporation and its subsidiaries in Japan, the U.S and other countries make no representations or warranties of any kind regarding this material, including, but not limited to, implied warranties of merchantability and fitness for a particular purpose. SATO Corporation shall not be held responsible for errors contained herein or any omissions from this material or for any damages, whether direct, indirect, incidental or consequential, in connection with the furnishing, distribution, performance or use of this material.

Specifications and contents in this document are subject to change without notice.

Trademarks

SATO is a registered trademark of SATO Corporation and its subsidiaries in Japan, the U.S. and other countries. All other trademarks are the property of their respective owners.

©2012 SATO Corporation.

All rights reserved.

Table of Contents

1. Default Settings	1
2. Font List	2
3. Command List	4
4. How to Read the Command Manual	10
5. Control Command	12
5.1 ESC+A Start Code.....	12
5.2 ESC+Z Stop Code.....	13
5.3 ESC+Q Print Quantity.....	14
5.4 ESC+ID Job ID Number.....	15
5.5 ESC+WK Job Name.....	16
6. Print Position Command	17
6.1 ESC+H Horizontal Print Position.....	17
6.2 ESC+V Vertical Print Position.....	18
7. Modification Command	19
7.1 ESC+P Character Pitch.....	19
7.2 ESC+L Character Expansion.....	20
7.3 ESC+PS Proportional Pitch.....	21
7.4 ESC+PR Release of Proportional Pitch.....	22
7.5 ESC+% Rotation (Base Reference Point Fixed).....	23
7.6 ESC+F Sequential Number.....	24
7.7 ESC+FW Print of Lines and Boxes.....	25
7.8 ESC+FC Print of Circles.....	26
7.9 ESC+FT Print of Triangles.....	27
7.10 ESC+(Reverse Image.....	28
7.11 ESC+KC Kanji Code.....	29
7.12 ESC+& Store Form Overlay.....	30
7.13 ESC+/ Recall Form Overlay.....	31
7.14 ESC+0 Partial Edit.....	32
7.15 ESC+WD Partial Copy.....	33

7.16	ESC+RF	Recall and Print of Font & Logo.....	34
7.17	ESC+J	Journal Print.....	35
7.18	ESC+RM	Mirror Image.....	36
7.19	ESC+%A	Clockwise Circular Arc.....	37
8.	Font Command.....		39
8.1	ESC+X20	X20 Font.....	39
8.2	ESC+X21	X21 Font.....	41
8.3	ESC+X22	X22 Font.....	43
8.4	ESC+X23	X23 Font.....	45
8.5	ESC+X24	X24 Font.....	47
8.6	ESC+OA	OCR-A Font.....	49
8.7	ESC+OB	OCR-B Font.....	51
8.8	ESC+\$	Outline Font Design	53
8.9	ESC+\$=	Outline Font Print.....	54
8.10	ESC+RD	CG Font.....	55
8.11	ESC+K1	16 x 16 Dots Horizontal Flow Kanji (JIS/Shift JIS/Unicode).....	56
8.12	ESC+K2	24 x 24 Dots Horizontal Flow Kanji (JIS/Shift JIS/Unicode).....	57
8.13	ESC+K3	22 x 22 Dots Horizontal Flow Kanji (JIS/Shift JIS/Unicode).....	58
8.14	ESC+K4	32 x 32 Dots Horizontal Flow Kanji (JIS/Shift JIS/Unicode).....	59
8.15	ESC+K5	40 x 40 Dots Horizontal Flow Kanji (JIS/Shift JIS/Unicode).....	60
8.16	ESC+K8	16 x 16 Dots Horizontal Flow Kanji with 1-Byte Chr. (Shift JIS/Unicode).....	61
8.17	ESC+K9	24 x 24 Dots Horizontal Flow Kanji with 1-Byte Chr. (Shift JIS/Unicode).....	62
8.18	ESC+KA	22 x 22 Dots Horizontal Flow Kanji with 1-Byte Chr. (Shift JIS/Unicode)	63
8.19	ESC+KB	32 x 32 Dots Horizontal Flow Kanji with 1-Byte Chr. (Shift JIS/Unicode).....	64
8.20	ESC+KD	40 x 40 Dots Horizontal Flow Kanji with 1-Byte Chr. (Shift JIS/Unicode)	65
8.21	ESC+k1	16 x 16 Dots Vertical Flow Kanji (JIS/Shift JIS/Unicode).....	66
8.22	ESC+k2	24 x 24 Dots Vertical Flow Kanji (JIS/Shift JIS/Unicode).....	67
8.23	ESC+k3	22 x 22 Dots Vertical Flow Kanji (JIS/Shift JIS/Unicode).....	68
8.24	ESC+k4	32 x 32 Dots Vertical Flow Kanji (JIS/Shift JIS/Unicode).....	69
8.25	ESC+k5	40 x 40 Dots Vertical Flow Kanji (JIS/Shift JIS/Unicode).....	70

8.26	ESC+k8	16 x 16 Dots Vertical Flow Kanji with 1-Byte Chr. (Shift JIS/Unicode).....	71
8.27	ESC+k9	24 x 24 Dots Vertical Flow Kanji with 1-Byte Chr. (Shift JIS/Unicode)	72
8.28	ESC+kA	22 x 22 Dots Vertical Flow Kanji with 1-Byte Chr. (Shift JIS/Unicode)	73
8.29	ESC+kB	32 x 32 Dots Vertical Flow Kanji with 1-Byte Chr. (Shift JIS/Unicode)	74
8.30	ESC+kD	40 x 40 Dots Vertical Flow Kanji with 1-Byte Chr. (Shift JIS/Unicode).....	75
8.31	ESC+T1	Store 16×16 Dots External Character	76
8.32	ESC+T2	Store 24 x 24 Dots External Character.....	78
8.33	ESC+K1 (K2)	Recall Horizontal Flow External Character	80
8.34	ESC+k1 (k2)	Recall Vertical Flow External Character	82
8.35	ESC+U	U Font	84
8.36	ESC+S	S Font.....	86
8.37	ESC+M	M Font.....	88
8.38	ESC+WB	WB Font.....	90
8.39	ESC+WL	WL Font.....	92
9.	Barcode Command	94
9.1	ESC+B	Barcode (Ratio 1:3).....	97
9.2	ESC+D	Barcode (Ratio 1:2)	99
9.3	ESC+D~ESC+d	Barcode (HRI).....	101
9.4	ESC+BD	Barcode (Ratio 2:5).....	102
9.5	ESC+BT	Variable Ratio Barcode.....	104
9.6	ESC+BW	Print of Variable Ratio Barcodes.....	105
9.7	ESC+BI	GS1-128 (UCC/EAN128)	108
9.8	ESC+BC	CODE93	110
9.9	ESC+BG	CODE128	112
9.10	ESC+BZ	Customer Barcode.....	116
9.11	ESC+BF	UPC Add-On Barcode	118
9.12	ESC+BL	UPC-A Barcode (No HRI)	119
9.13	ESC+BL~ESC+d	UPC-A Barcode (HRI)	120
9.14	ESC+BM	UPC-A Barcode (HRI).....	121
9.15	ESC+BP	POSTNET	122

10. 2D Code Commands	124
10.1 ESC+2D10 PDF417	124
10.2 ESC+2D12 Micro PDF	127
10.3 ESC+2D20 MAXI Code	130
10.4 ESC+2D30 QR Code (Model 2)	132
10.5 ESC+2D31 QR Code (Model 1)	136
10.6 ESC+2D32 Micro QR	139
10.7 ESC+2D33 SQR Code	164
10.8 ESC+2D50 GS1 DataMatrix (ECC200)	168
11. Composite Symbol Commands	170
11.1 ESC+EU Composite Symbol	170
12. Graphic Commands	173
12.1 ESC+G Custom Graphics	173
12.2 ESC+GM BMP File	174
13. System Command	175
13.1 ESC+CS Print Speed	175
13.2 ESC+#E Print Darkness	176
13.3 ESC+A1 Media Size	177
13.4 ESC+A3 Base Reference Point	178
13.5 ESC+* Clear	179
13.6 ESC+@ Offline	180
13.7 ESC+C Repeat	181
13.8 ESC+PG Printer Setup	182
13.9 ESC+E Line Feed	185
13.10 ESC+IG Sensor Type	186
13.11 ESC+PM Printer Type	187
13.12 ESC+PO Offset	188
13.13 ESC+TW Waiting Time for Tear-off	189
13.14 ESC+TK Forced Tear-Off Motion	190
13.15 ESC+KM Mincho-Type Kanji	191

13.16	ESC+KG	Gothic-Type Kanji	192
14.	Memory Card Commands		193
14.1	ESC+CC	Card Slot.....	193
14.2	ESC+FM	Format Memory Card.....	194
14.3	ESC+FP	Print Memory Card Status	195
14.4	ESC+&S	Store Form Overlay.....	196
14.5	ESC+&R	Recall Form Overlay	198
14.6	ESC+YS	Store Format	199
14.7	ESC+/N	Store Field.....	202
14.8	ESC+YR	Recall Format.....	203
14.9	ESC+/D	Print Field	204
14.10	ESC+GI	Store Graphic.....	205
14.11	ESC+GR	Recall Graphic.....	206
14.12	ESC+GT	Store BMP File.....	207
14.13	ESC+GC	Recall BMP File	208
14.14	ESC+T1	Store 16 x 16 External Character to Memory Card.....	209
14.15	ESC+T2	Store 24x24 Dots External Character to Memory Card.....	210
14.16	ESC+K1(K2)	Call Horizontally Flow External Chr. Stored in Memory Card.....	211
14.17	ESC+k1(k2)	Call Vertical Flow External Chr. Stored in Memory Card	212
14.18	ESC+*	Clear (Memory Card).....	213
15.	Extended Function		215
15.1	ESC+IK	Media Feed Control	215
15.2	ESC+IM	LCD Display Message.....	217
15.3	ESC+IF	Store Internal Buffer.....	218
15.4	ESC+IB	Call Internal Buffer	219
15.5	ESC+IC	Internal Buffer Data Comparison	221
15.6	ESC+I*	Print Internal Buffer Data	222
15.7	ESC+I#	Exclusive Use of Key	223
15.8	ESC+IZ	Key Entry.....	225
15.9	ESC+IR	Internal Buffer Store (Receive Data).....	226

15.10	ESC+IT	Data Transmission	228
15.11	ESC+IO	External Signal Input / Output.....	230
15.12	ESC+IW	Print Time Delay	232
15.13	ESC+IU	Audible Buzzer	233
15.14	ESC+I@	Initialization of Internal Buffer	234
15.15	ESC+IY	Exclusive Use of Display.....	235
Appendix	Unicode Code Table (Special Kanji)	236

1. Default Settings

Default values are as follows.

Item	HR212	HR224
Print speed	2.0 inch/sec (50mm/sec) [Range: 1.0, 1.5, 2.0, 2.5, 3.0, 3.5, 4.0]	
Darkness range	A	
Print darkness	3 [Range: 1, 2, 3, 4, 5]	
Offset	+0	
Zero font switching	NO	
Kanji Code	NEC font: JIS Ryobi font: Shift JIS	
Proportional pitch	Fixed pitch	

2. Font List

To use residential fonts, specify ESC+ (relevant font command).

Font	Font type	Pitch
U	Bitmap[U font] 28x57 dots	Fixed
S	Bitmap[S font] 8x12 dots	Fixed
M	Bitmap[M font] 19x23 dots	Fixed
WB	Bitmap[WB font] 18x30 dots	Fixed
WL	Bitmap[WL font] 28x52 dots	Fixed
OA (12dot/mm)	Bitmap[OCR-A font] 22x33 dots	Fixed
OB (12dot/mm)	Bitmap[OCR-B font] 30x36 dots	Fixed
OA(24dot/mm)	Bitmap[OCR-A font] 44x66 dots	Fixed
OB(24dot/mm)	Bitmap[OCR-B font] 60x72 dots	Fixed
X20	Bitmap[X20 font] 5x9 dots	Fixed
X21	Bitmap[X21 font] 17x17 dots	Fixed / Proportional
X22	Bitmap[X22 font] 24x24 dots	Fixed / Proportional
X23	Bitmap[X23 font] 48x48 dots	Fixed / Proportional
X24	Bitmap[X24 font] 48x48 dots	Fixed / Proportional
K1	Bitmap[Kanji font] 16x16 dots	Fixed
K2	Bitmap[Kanji font] 24x24 dots	Fixed
K3	Bitmap[Kanji font] 22x22 dots	Fixed
K4	Bitmap[Kanji font] 32x32 dots	Fixed
K5	Bitmap[Kanji font] 40x40 dots	Fixed
K8	Bitmap[Kanji font] 16x16 dots	Fixed
K9	Bitmap[Kanji font] 24x24 dots	Fixed
KA	Bitmap[Kanji font] 22x22 dots	Fixed
KB	Bitmap[Kanji font] 32x32 dots	Fixed
KD	Bitmap[Kanji font] 40x40 dots	Fixed
\$ (shape)	Outline font	Fixed / Proportional
\$= (print)	Kanji outline font	Fixed
RD	CG font[CG Times]	Fixed / Proportional
	CG font[CG Triumvirate]	Fixed / Proportional

Expanded font

Font can be expanded by a factor of 1 to 12.

Internal bitmap fonts can also be expanded with a factor of 1 to 12.

Example: A font in a size of 5 dots of width and 9 dots of height is expanded by a factor of 3. The resulting font has a width of 15 dots and a height of 27 dots.

The input of expansion factors (height x expansion factor, width x expansion factor) for characters to be printed is done as described below: —

Width x Expansion factor= Width parameter setting value

Height x Expansion factor= Height parameter setting value

The command <L> decides the expansion of the character. This parameter is set as factor.

Example: If setting the factor to: <L>0304, the character is expanded by a factor of 3 in horizontal direction (width) and a factor of 4 in vertical direction (height)

If a expansion factor is specified, also the pitch between the characters is automatically determined.

Fixed pitch / proportional pitch

For the X21-X24 font, the outline font and the CG font, it is possible to select between the fixed and the proportional pitch. The proportional pitch is can be set via the LCD screen of the printer: Setting: <PS>, Release: <PR>.

Depending on the font, the width of the proportional pitch does differ. Kata-kana is not affected by the proportional pitch. Note that the width of alphanumeric is narrowed by the proportional pitch.

For the fixed pitch, the character width is based on the relevant font size selected.

Difference between outline font and bitmap font

For the bitmap font the height and the width of the font is predefined. The height of the bitmap font is a little bit larger than the width.

The bitmap font is the largest in the font matrix.

For the font type and size refer to the font list on the previous page.

For the outline font, if setting the height and the width of the font properly, the smooth scaling algorithm of the printer allows a well balanced font. It is also possible to define some style options like a gray scale and a shadow setting.

3. Command List

o: Available / X: Not available

Category	Command	HR200	Restriction
Control	Start Code	<A>	o
	Stop Code	<Z>	o
	Print Quantity	<Q>	o
	Job ID Number	<ID>	o
	Job Name	<WK>	o
Print position	Horizontal Print Position	<H>	o
	Vertical Print Position	<V>	o
Modification	Character Pitch	<P>	o
	Character Expansion	<L>	o
	Proportional Pitch	<PS>	o
	Release of Proportional Pitch	<PR>	o
	Rotation (Fixed Base Reference Point)	<%>	o
	Sequential Number	<F>	o
	Print of Lines and Boxes	<FW>	o
	Print of Circles	<FC>	o
	Print of Triangles	<FT>	o
	Reverse Image	<(>	o
	Kanji Code	<KC>	o
	Store Form Overlay	<&>	o
	Recall Form Overlay	</>	o
	Partial Edit	<O>	o
	Partial Copy	<WD>	o
	Journal Print	<J>	o
	Recall and Print of Font & Logo	<RF>	o
	Mirror Image	<RM>	o
	Small Label Size Specification	<PD>	x
	Small Label Start	<_F>	x
	Format	<_N>	x
	Variable Data Specification	<_D>	x
	Print Quantity	<_Q>	x
	Label Size	<RI>	x
	Sheet Unit Copy Quantity	<RW>	x
	Sheet Unit Cut Quantity	<RC>	x
	Print Order	<RT>	x
Telegraphic Message End Specification	<RE>	x	
Sheet Sending Specification	<RS>	x	
Clockwise Circular Arc	<%A>	o	
Font	X20 Font	<X20>	o
	X21 Font	<X21>	o
	X22 Font	<X22>	o
	X23 Font	<X23>	o
	X24 Font	<X24>	o
	XU Font	<XU>	x
	XS Font	<XS>	x
	XM Font	<XM>	x
	XB Font	<XB>	x
	XL Font	<XL>	x
	OCR-A Font	<OA>	o

Category	Command	HR200	Restriction	
Font	OCR-B Font	<OB>	o	
	Outline Font Design	<\$>	o	
	Outline Font Print	<\$=>	o	
	CG Font	<RD>	o	
	16x16 Dots Horizontal Flow Kanji	<K1>	o	
	24x24 Dots Horizontal Flow Kanji	<K2>	o	
	22x22 Dots Horizontal Flow Kanji	<K3>	o	
	32x32 Dots Horizontal Flow Kanji	<K4>	o	
	40x40 Dots Horizontal Flow Kanji	<K5>	o	
	16x16 Dots Horizontal Flow Kanji with 1-Byte Chr	<K5>	X	
	24x24 Dots Horizontal Flow Kanji with 1-Byte Chr	<K6>	X	
	16x16 Dots Horizontal Flow Kanji with 1-Byte Chr	<K8>	o	
	24x24 Dots Horizontal Flow Kanji with 1-Byte Chr	<K9>	o	
	22x22 Dots Horizontal Flow Kanji with 1-Byte Chr	<KA>	o	
	32x32 Dots Horizontal Flow Kanji with 1-Byte Chr	<KB>	o	
	40x40 Dots Horizontal Flow Kanji with 1-Byte Chr	<KD>	o	
	16x16 Dots Vertical Flow Kanji	<k1>	o	
	24x24 Dots Vertical Flow Kanji	<k2>	o	
	22x22 Dots Vertical Flow Kanji	<k3>	o	
	32x32 Dots Vertical Flow Kanji	<k4>	o	
	40x40 Dots Vertical Flow Kanji	<k5>	o	
	16x16 Dots Vertical Flow Kanji	<k5>	X	
	24x24 Dots Vertical Flow Kanji	<k6>	X	
	16x16 Dots Vertical Flow Kanji with 1-Byte Chr	<k8>	o	
	24x24 Dots Vertical Flow Kanji with 1-Byte Chr	<k9>	o	
	22x22 Dots Vertical Flow Kanji with 1-Byte Chr	<KA>	o	
	32x32 Dots Vertical Flow Kanji with 1-Byte Chr	<KB>	o	
	40x40 Dots Vertical Flow Kanji with 1-Byte Chr	<KC>	o	
	Store 16x16 Dots External Character	<T1>	o	
	Store 24x24 Dots External Character	<T2>	o	
	Store 22x22 Dots External Character	<T3>	X	
	Store 32x32 Dots External Character	<T4>	X	
	Store 40x40 Dots External Character	<T5>	X	
	Recall Vertical Flow External Character	<K1>	o	<K1>, <K2> only
		<K2>		
		<K3>		
		<K4>		
		<K5>		
	Recall Horizontal Flow External Character	<k1>	o	<k1>, <k2> only
		<k2>		
		<k3>		
		<k4>		
<k5>				
X1 Font	<X1>	X		
X2 Font	<X2>	X		
X3 Font	<X3>	X		

Category	Command	HR200	Restriction
Font	X70 Font	<X70>	X
	X71 Font	<X71>	X
	X72 Font	<X72>	X
	X73 Font	<X73>	X
	X74 Font	<X74>	X
	X75 Font	<X75>	X
	X76 Font	<X76>	X
	X77 Font	<X77>	X
	WL Font	<WL>	o
	WB Font	<WB>	o
	X80 Font	<X80>	X
	X81 Font	<X81>	X
	X82 Font	<X82>	X
	X83 Font	<X83>	X
	X84 Font	<X84>	X
	X85 Font	<X85>	X
	X86 Font	<X86>	X
	X87 Font	<X87>	X
	X88 Font	<X88>	X
	X89 Font	<X89>	X
	X90 Font	<X90>	X
	X91 Font	<X91>	X
	X92 Font	<X92>	X
	X93 Font	<X93>	X
	XCS Font	<XCS>	X
	XCL Font	<XCL>	X
	U Font	<U>	o
	S Font	<S>	o
M Font	<M>	o	
Barcode	Barcode (Ratio 1:3)		o
	Barcode (Ratio 1:2)	<D>	o
	Barcode (HRI)	<D>~<d>	o
	Barcode (Ratio 2:5)	<BD>	o
	Variable Ratio Barcode	<BT>	o
	Print of Variable Ratio Barcodes	<BW>	o
	GS1-128 (UCC/EAN128)	<BI>	o
	CODE93	<BC>	o
	CODE128	<BG>	o
	Customer Barcode	<BZ>	o
	POSTNET	<BP>	o
	UPC Add-On Barcode	<BF>	o
	GS1 DataBar Composite Symbol	<EU>	o
	UPC-A Barcode (No HRI)	<BL>	o
	UPC-A Barcode (HRI)	<BL> ~<d>	o
	UPC-A Barcode (HRI)	<BM>	o
	2D code	PDF417	<2D10>
PDF417		<BK>	X
Micro PDF		<2D12>	o
MAXI code		<2D20>	o
MAXI code		<BV>	X
QR Code (Model 2)		<2D30>	o
QR Code (Model 1)		<2D31>	o
Micro QR		<2D32>	o
QR code		<BQ>	X

--	--	--	--

Category	Command	HR200	Restriction	
2D code	SQR Code	<2D33>	○	
	DataMatrix (ECC200)	<2D50>	○	
	DataMatrix	<BX>	X	
	DataMatrix (Data)	<DC>	X	
	DataMatrix (Sequential number)	<FX>	X	
Graphic	Custom Graphics	<G>	○	
	BMP File	<GM>	○	
System	Print Speed	<CS>	○	
	Print Darkness	<#E>	○	
	Media Size	<A1>	○	
	Media Size (mm)	<A1>	X	
	Base Reference Point	<A3>	○	[Valid range] H: ±792 dots ,W: ±792 dots
	Reference Position	<#>	X	
	Print Area Enlargement	<AX>	X	
	Standard Print Area	<AR>	X	
	Print End Position	<EP>	○	
	Multi cut	<~>	X	
	Cut Number Unit	<CT>	X	
	Cut Number Unit	<~A>	X	
	Eject and Cut	<NC>	X	
	Eject and Cut	<YC>	X	
	Eject and Cut	<~B>	X	
	Eject	<EJ>	X	
	Batch Separator	< >	X	
	Clear	<*>	○	
	Offline	<@>	○	
	Repeat	<C>	○	
	Printer Setup	<PG>	○	
	Printer Setup	<PC>	X	
	Line Feed	<E>	○	
	Two-Color Print Range	<2S>	X	
	Two-Color Print	<2C>	X	
	Offset	<PO>	○	
	Sensor Type	<IG>	○	
	Media Type	<YE>	X	
	Mincho-Type Kanji	<KM>	○	
	Gothic-Type Kanji	<KG>	○	
Control Code	<CO>	X		
IEEE1284	<I1>	X		
PIN Code	<I6>	X		
Authentication Mode	<I7>	X		
Device Name	<I8>	X		
Bluetooth Mode	<BS>	X		

Category	Command	HR200	Restriction
	Eject and Cut	<CX>	X
	Forced Tear Off	<TK>	o
	Battery Mode	<TB>	X
	Waiting Time for Tear Off	<TW>	o
	Media Type	<FR>	X
	Eject	<FO>	X
	Offset Data	<OF>	X
	Printer Type	<PM>	o
Memory card	Card Slot	<CC>	o
	Format Memory Card	<FM>	o
	Print Memory Card Status	<FP>	o
	Memory Area Enlarge Specification	<EX>	X
	Store Form Overlay	<&S>	o
	Recall Form Overlay	<&R>	o
	Store Format	<YS>	o
	Store Field	</N>	o
	Recall Format	<YR>	o
	Print Field	</D>	o
	Store Graphic	<GI>	o
	Recall Graphic	<GR>	o
	Store BMP File	<GT>	o
	Recall BMP File	<GC>	o
	Store 16x16 Dots External Character	<T1>	o
	Store 24x24 Dots External Character	<T2>	o
	Call Vertical Flow External Character	<K1> <K2>	o
	Call Horizontal Flow External Character	<k1> <k2>	o
	Outline Font Design	<\$>	o
	Outline Font Print	<\$=>	o
Clear (Memory card)	<*>	o	
Calendar	Calendar Configuration	<WT>	X
	Calendar Increment	<WP>	X
	Calendar Print	<WA>	X
Extended Func.	Media Feed Control	<IK>	o
	LCD Display Message	<IM>	o
	Stire Internal Buffer	<IF>	o
	Call Internal Buffer	<IB>	o

o: Available / X: Not available

Category	Command		HR200	Restriction
Extended Func.	Internal Buffer Data Comparison	<IC>	o	
	Print Internal Buffer Data	<I*>	o	
	Exclusive Use of Key	<I#>	o	
	Key Entry	<IZ>	o	
	Internal Buffer Store (Receive Data)	<IR>	o	
	Data Transmission	<IT>	o	
	External Signal Input/Output	<IO>	o	
	Print Time Delay	<IW>	o	
	Audible Buzzer	<IU>	o	
	Initialization of Internal Buffer	<I@>	o	
	Exclusive Use of Display	<IY>	o	

4. How to Read the Command Manual

7.2 Modification

1)

2)

3)

Character Expansion

ESC+L

4) →	HEX code	ESC <1B> ₁₆	L <4C> ₁₆	Parameter aabb	← 5)
6) →	Initial value	aa=01, bb=01			

7) →	Validity and valid duration of command	When the power switch is off	Set parameter will not be retained.
		Validity in a job	Set parameter will be retained until next valid setting.
		Validity after a job	Set parameter will be the default value for the next job <A>.

8) [Function]
Specifying the print expansion factor.

9) [Format]
<L>aabb
• Parameter

a	[Horizontal expansion factor (width)]	=	validity range	: 01 to 12
b	[Vertical expansion factor (height)]	=	validity range	: 01 to 12

10) [Example] Horizontal expansion factor (width): 4, Vertical expansion factor (height): 3
<A>
<V>100<H>200<P>3<L>**0403**<X21>,ABCD
<Q>2
<Z>

11) [Note]
1. This command enlarges the character pitch as well. When the Character Pitch <P> is used at the same time, the parameter value of horizontal expansion ratio specified in the Character Expansion <L> will be reflected in the subsequent specification <P>.

12) [Tip]
1. When increasing the enlargement ratio, design the print format that does not exceed print area.

13) [Valid commands]

Font	<X20>	<X21>	<X22>	<X23>	<X24>	<K1>	<K2>	<K3>	<K4>	<K5>
	<K8>	<K9>	<k1>	<k2>	<k3>	<k4>	<k5>	<k8>	<k9>	<RD>
Modification	<P>	<RF>								
Graphic	<G>	<GM>								
Memory card	<GR>	<GC>								

- 1) The types of commands such as:
[Control], [Print position], [Modification], [Font], [Barcode], [2-D code], [Graphic], [System], [Memory card] and [Extended function].
- 2) Indicates the command name.
- 3) Indicates the command code.
- 4) Indicates the command in hexadecimal code.
- 5) Indicates the parameter to be described in a command string.
- 6) Indicates the initial value of the command.

7) Validity and valid duration of command

- When the printer is powered off
 - (1) The set parameter is maintained.
 - (2) The set parameter is not maintained.
 - (3) The set command becomes invalid.

- Validity in a job
 - (1) The set parameter is valid until a new command is specified.
 - (2) The set parameter becomes invalid.
 - (3) The set command becomes invalid.
 - (4) The set parameter is valid within the field.

- Valid after a job
 - (1) The set parameter becomes the initial value at the next item <A>.
 - (2) The set parameter is valid until a new command is specified.
 - (3) The set parameter becomes invalid.
 - (4) The set command becomes invalid.

8) Explains the function of command.

9) Explains the command and required parameter.

<L>aabb indicates the ESC+L (<1B>_i<4C>_i) command with the parameters aa and bb

10) Shows the example of how the command is used.

If putting out a code via RS-232C to a printer connected, the programming will be done in BASIC language:

```
10 ESC$=CHR$(&H1B)
20 OPEN "COM1 : 9600,N,8,1,RS,BIN" FOR OUTPUT AS #1
30 PRINT #1,ESC$ ; "A" ;
40 PRINT #1,ESC$ ; "V100" ; ESC$ ; "H200" ;
50 PRINT #1,ESC$ ; "P2" ; ESC$ ; "L0403" ;
60 PRINT #1,ESC$ ; "X22,PRINT" ;
70 PRINT #1,ESC$ ; "Q2" ;
80 PRINT #1,ESC$ ; "Z" ;
90 CLOSE #1
100 END
```

11) Provides the information of command function and parameter.

12) Provides points of concern and restrictions for the use of command.

13) Shows the commands to be affected by the use of particular command.

5. Control Command

5.1 Control			
Start Code			ESC+A
HEX code	ESC	A	Parameter
	<1B> ₁₆	<41> ₁₆	None
Initial value	None		

Validity and valid duration of command	When the power switch is off	The set command is not maintained.
	Validity in a job	The set command becomes invalid.
	Validity after a job	The set command becomes invalid.

[Function]

Specifies the start of data transmission.

[Format]

<A>

[Example]

<A>
 <V>100<H>200<P>2<L>0202<X21>,ABCD
 <Q>2
 <Z>

[Note]

1. This command indicates the start of data and must be followed by the data to be printed.
2. For all print jobs, the Start Code <A> command must precede the data and the Stop Code <Z> command must follow.

[Tip]

1. All the command setting values except some part of system commands will be the initial value.
2. No print operation will occur without this command.

5.2 Control

Stop Code		ESC+Z	
HEX code	ESC <1B> ₁₆	Z <5A> ₁₆	Parameter None
Initial value	None		

Validity and valid duration of command	When the power switch is off	The set command is not maintained.
	Validity in a job	The set command becomes invalid.
	Validity after a job	The set command becomes invalid.

[Function]

Specifies the end of data transmission.

[Format]

<Z>

[Example]

<A>
<V>100<H>200<P>2<L>0202<X21>,ABCD
<Q>2
<Z>

[Note]

1. This command indicates the end of data and must be placed at the end of data.
2. For all print jobs, the Start Code <A> command must precede the data and the Stop Code <Z> command must follow.

[Tip]

1. No print operation will occur without this command.

5.3 Control

Print Quantity		ESC+Q	
-----------------------	--	--------------	--

HEX code	ESC	Q	Parameter
	<1B> ₁₆	<51> ₁₆	aaaaaa
Initial value	aaaaaa=1		

Validity and valid duration of command	When the power switch is off	The set parameter is not maintained.
	Validity in a job	The set parameter becomes invalid.
	Validity after a job	The set parameter becomes invalid.

[Function]

Specifies the total quantity of tags or labels to print for a given print job.

[Format]

<Q>aaaaaa

• Parameter

a [Print quantity] = 1 to 999999

[Example] 2 pages to be print

```
<A>
<V>100<H>200<P>2<L>0202<X21>,ABCD
<Q>2
<Z>
```

[Note]

1. The data between the Start Code <A> and the Stop Code <Z> is regarded as one page. <Q> defines how many pages of the same content shall be printed out.
2. This command must be followed by the Stop Code <Z> command.

[Tip]

1. Reprint will be performed based on the specified print quantity. When used with the Sequential Numbering <F> command, the sequential number for the specified field only will be printed.

5.4 Control

Job ID Number		ESC+ID	
HEXcode	ESC	ID	Parameter
	<1B> ₁₆	<49> ₁₆ <44> ₁₆	aa
Initial value	aa=<20> ₁₆		

Validity and valid duration of command	When the power switch is off	The set parameter is not maintained.
	Validity in a job	The set parameter is valid until a new command is specified.
	Validity after a job	The set parameter becomes invalid.

[Function]

Specifies the job ID number for status return.

[Format]

<ID>aa

• Parameter

a [Job ID number] = 00 to 99

[Example] Job ID number: 01

<A>

<ID>01

<V>200<H>100<P>0<\$>B,100,100,6

<\$>SATOPRINTER

<Q>2

<Z>

[Note]

1. When using the status return for communication protocol, the job ID number can be set to the status telegram.
2. Status can be checked sending status request (ENQ).
3. Use this command within the data placed between the Start Code <A> command and the Stop Code <Z> command.
4. When STATUS5 is used, the job ID valid range becomes [00000 to 99999] or [*****]. By specifying [*****], the item will not be managed by the job ID number.

[Tip]

1. In status return communication protocol, this command becomes valid when status request (ENQ) is received while printing (including when QTY≠0, and in both offline and error state).
2. In status return communication protocol, if status request (ENQ) is received when printing is not in progress (QTY=0, No received data when powered on), space (20H) will be set to the status and returned.
3. If more than one Job Store ID number are in a single job, the last number specified will be valid.
4. For more details, refer to the Interface Specifications.

5.5 Control			
Job Name			ESC+WK
HEX code	ESC	WK	Parameter
	<1B> ₁₆	<57> ₁₆ <4B> ₁₆	aaaaaaaaaaaaaaaa
Initial value	aaaaaaaaaaaaaaaa=<20> ₁₆		
Validity and valid duration of command	When the power switch is off	The set parameter is not maintained.	
	Validity in a job	The set parameter is valid until a new command is specified.	
	Validity after a job	The set parameter becomes invalid.	

[Function]

Specifies the job name for status return.

[Format]

<WK>aaaaaaaaaaaaaaaa

• Parameter

a [Job name] = 16 ASCII characters, 8 Shift JIS Kanji characters

[Example] Job name: SATO

<A>

<WK>SATO

<V>200<H>100<P>0<\$>B,100,100,6

<\$>=SATOPRINTER

<Q>2

<Z>

[Note]

1. When the protocol for driver is used for communication protocol, a job name can be set to the status telegram.
2. Status can be checked sending status request (ENQ).
3. Use this command within the data placed between the Start Code <A> command and the Stop Code <Z> command.
4. This command can be used in combination with the Job Store ID <ID> command.

[Tip]

1. In status return communication protocol, this command becomes valid when status request (ENQ) is received while printing (including when QTY≠0, and in both offline and error state).
2. In status return communication protocol, if status request (ENQ) is received when printing is not in progress (QTY=0, No received data when powered on), space (20H) will be set to the status and returned.
3. If more than one job names are in a single job, the last name transmitted will be valid.
4. For more details, refer to the Interface Specifications.

6. Print Position Command

6.1 Print Position			
Horizontal Print Position			ESC+H
HEX code	ESC <1B> ₁₆	H <48> ₁₆	Parameter aaaa
Initial value	aaaa=1		
Validity and valid duration of command	When the power switch is off	The set parameter is not maintained.	
	Validity in a job	The set parameter is valid until a new command is specified.	
	Validity after a job	The set parameter becomes the initial value at the next item <A>.	

[Function]

Specifies horizontal print position from its base point in dots.

[Format]

<H>aaaa

- Parameter
a [Horizontal print position] = See the table below.

[Example] Horizontal print position: 200 dots

```
<A>
<V>100<H>200<P>2<L>0202<X21>,ABCD
<Q>2
<Z>
```

[Note]

1. Specifying the start of horizontal position for printing text, barcodes, lines and graphics.

[Tip]

1. Any contents such as text, barcodes and graphics, exceed printable area will not print.

[Initial value and validity of parameter]

Model	Default	Range (dots)
HR212	1	1 to 672
HR224	1	1 to 1344

[Valid commands]

Font	<X20>	<X21>	<X22>	<X23>	<X24>	<K1>	<K2>	<K3>	<K4>	<K5>
	<K8>	<K9>	<k1>	<k2>	<k3>	<k4>	<k5>	<k8>	<k9>	<RD>
	<OA>	<OB>	<\$=>							
Barcode		<BC>	<BG>	<BI>	<BZ>	<D>	<D><d>	<BD>	<BT>	<BW>
	<BF>	<BL>	<BL><d>	<BM>						
2D code	<2D10>	<2D12>	<2D20>	<2D30>	<2D31>	<2D32>	<2D33>	<2D50>		
Composite code	<EU>									
Modification	<WD>	<FW>	<(>	<RF>	<FC>	<FT>	<RM>	<%A>		
Graphic	<G>	<GM>								
Memory card	<GR>	<GC>								

6.2 Print Position

Vertical Print Position		ESC+V	
HEX code	ESC <1B> ₁₆	V <56> ₁₆	Parameter aaaa
Initial value	aaaa=1		

Validity and valid duration of command	When the power switch is off	The set parameter is not maintained.
	Validity in a job	The set parameter is valid until a new command is specified.
	Validity after a job	The set parameter becomes the initial value at the next item <A>.

[Function]

Specifies vertical print position from its base point in dots.

[Format]

<V>aaaa

- Parameter
a [Vertical print position] = See the table below.

[Example] Vertical print position: 100 dots

```
<A>
<V>100<H>200<P>2<L>0202<X21>,ABCD
<Q>2
<Z>
```

[Note]

1. Specifying the start of vertical position for printing text, barcodes, lines and graphics.

[Initial value and validity of parameter]

Model	Default	Range (dots)
HR212	1	1 to 2400
HR224	1	1 to 4800

[Valid commands]

Font	<X20>	<X21>	<X22>	<X23>	<X24>	<K1>	<K2>	<K3>	<K4>	<K5>
	<K8>	<K9>	<k1>	<k2>	<k3>	<k4>	<k5>	<k8>	<k9>	<RD>
	<OA>	<OB>	<\$=>							
Barcode		<BC>	<BG>	<BI>	<BZ>	<D>	<D><d>	<BD>	<BT>	<BW>
	<BF>	<BL>	<BL><d>	<BM>						
2D code	<2D10>	<2D12>	<2D20>	<2D30>	<2D31>	<2D32>	<2D32>	<2D50>		
Composite code	<EU>									
Modification	<WD>	<FW>	<<>	<RF>	<FC>	<FT>	<RM>	<%A>		
Graphic	<G>	<GM>								
Memory card	<GR>	<GC>								

7. Modification Command

7.1 Modification			
Character Pitch			ESC+P
HEX code	ESC <1B> ₁₆	P <50> ₁₆	Parameter aa
Initial value	aa=02		
Validity and valid duration of command	When the power switch is off	The set parameter is not maintained.	
	Validity in a job	The set parameter is valid within the field.	
	Validity after a job	The set parameter becomes the initial value at the next item <A>.	

[Function]

Specifies the spacing (in dots) between characters.

[Format]

<P>aa

- Parameter
a [Character pitch] = 00 to 99 dots

[Example] Character pitch: 10

```
<A>
<V>100<H>200<P>10<L>0202<X21>,ABCD
<Q>2
<Z>
```

[Example] Barcode specified, Inter-character pitch: 10

```
<A>
<V>100<H>200<L>0202<P>10<B>103120*1234AB*
<Q>2
<Z>
```

[Note]

1. Character pitch is a spacing between characters and fonts when selecting fonts and barcodes.
2. This command is affected by the Character Expansion <L> command.
3. Even if the linefeed code [CR] is specified by the Linefeed <E> command, it does not revert to the initial value. Use the Start Code <A> command to revert to the initial value.
4. By specifying this command just before the barcode specification, the pitch command becomes valid for barcode module.
Object barcode: CODABAR(NW-7) / CODE39 / Industrial 2of5 / Matrix 2of5
For more details, refer to [9. Barcode Specification - (3) Intercharacter gap].
5. Data specification except numeric value or specification of over-digit will revert to the initial value.

[Valid commands]

Font	<X20>	<X21>	<X22>	<X23>	<X24>	<K1>	<K2>	<K3>	<K4>	<K5>
	<K8>	<K9>	<k1>	<k2>	<k3>	<k4>	<k5>	<k8>	<k9>	<RD>
	<OA>	<OB>	<\$=>							
Modification	<RF>									
Barcode		<D>	<D><d>	<BD>	<BT>	<BW>				
Composite code	<EU>									

7.2 Modification

Character Expansion	ESC+L
----------------------------	--------------

HEX code	ESC <1B> ₁₆	L <4C> ₁₆	Parameter aabb
Initial value	aa=01, bb=01		

Validity and valid duration of command	When the power switch is off	The set parameter is not maintained.
	Validity in a job	The set parameter is valid until a new command is specified.
	Validity after a job	The set parameter becomes the initial value at the next item <A>.

[Function]

Specifying the enlargement ratio of font to be printed.

[Format]

<L>aabb

• Parameter

a	[Horizontal expansion]	=	01 to 12 times
b	[Vertical expansion]	=	01 to 12 times

[Example] Horizontal expansion: 4 times, Vertical expansion: 3 times

```
<A>
<V>100<H>200<P>3<L>0403<X21>,ABCD
<Q>2—
<Z>
```

[Note]

1. This command will affect character pitch. When the Character Pitch <P> command is used with this command, the parameter for horizontal enlargement ratio specified by this command will affect the subsequent Character Pitch <P> command.

[Tip]

1. When increasing the enlargement ratio, design the print format that does not exceed print area.

[Valid commands]

Font	<X20>	<X21>	<X22>	<X23>	<X24>	<K1>	<K2>	<K3>	<K4>	<K5>
	<K8>	<K9>	<k1>	<k2>	<k3>	<k4>	<k5>	<k8>	<k9>	<OA>
	<OB>									
Modification	<P>	<RF>								
Graphics	<G>	<GM>								
Memory card	<GR>	<GC>								

7.3 Modification

Proportional Pitch		ESC+PS	
HEX code	ESC <1B> ₁₆	PS <50> ₁₆ <53> ₁₆	Parameter None
Initial value	None		
Validity and valid duration of command	When the power switch is off	The set command is not maintained.	
	Validity in a job	The set command is valid until a new command is specified.	
	Validity after a job	The set command becomes valid.	

[Function]

Specifies the proportional spacing.

[Format]

<PS>

[Example]

<A>

<PS>

<V>100<H>200<P>2<L>0202<X21>,ABCD

<Q>2

<Z>

[Note]

1. This command does not enable to print Katakana font with proportional spacing. On the other hand, this command will make the width of alphanumeric narrower.
2. The printing of proportional spacing will not occur when selecting the data other than specified.
3. In the printer initial state, the setting of the Release of Proportional Pitch <PR> is [Fixed]. [Proportional Pitch] can be changed to the initial value through the printer LCD display or the printer setting tool.

[Valid commands]

Font	<X21>	<X22>	<X23>	<X24>	<RD>	<\$=>				
Modification	<RF>									

7.4 Modification

Release of Proportional Pitch

ESC+PR

HEX code	ESC <1B> ₁₆	PR <50> ₁₆ <52> ₁₆	Parameter None
Initial value	None		

Validity and valid duration of command	When the power switch is off	The set command is not maintained.
	Validity in a job	The set command is valid until a new command is specified.
	Validity after a job	The set command becomes valid.

[Function]

Cancels the printing of proportional spacing.

[Format]

<PR>

[Codeing example]

<A>

<PR>

<V>100<H>200<P>2<L>0202<X21>,ABCD

<Q>2

<Z>

[Note]

1. In the printer initial state, the setting of the Release of Proportional Pitch <PR> is [Fixed]. [Proportional Pitch] can be changed to the initial value through the printer LCD display or the printer setting tool.

[Valid commands]

Font	<X21>	<X22>	<X23>	<X24>	<RD>	<\$=>				
Modification	<RF>									

7.5 Modification

Rotation (Base Reference Point Fixed)		ESC+%	
HEX code	ESC <1B> ₁₆	% <25> ₁₆	Parameter a
Initial value	a=0		

Validity and valid duration of command	When the power switch is off	The set parameter is not maintained.
	Validity in a job	The set parameter is valid until a new command is specified.
	Validity after a job	The set parameter becomes the initial value at the next item <A>.

[Function]

Rotates fonts and barcodes in the counterclockwise direction.

[Format]

<%>a

• Parameter

a [Rotation direction] = 0 : Parallel 1 (0 degree) 1 : Serial 1 (90 degree)
2 : Parallel 2 (180 degree) 3 : Serial 2 (270 degree)

[Example] Font rotation: Parallel 2, Barcode rotation: Serial 1

<A>

<%>2

<V>100<H>400<P>3<L>0403<X21>,ABCD

<%>1

<V>600<H>300<BD>103080*123*

<Q>2

<Z>

[Note]

- The positions specified by Vertical Print Position <V> and Horizontal Print Position <H> commands are based on the absolute value from its base point.
- When the parameter "a" is set between 4 and 9, this input will be ignored as a command error and printing at zero degree. When the value other than numeric is specified, this input will be ignored and printing at zero degree.
- Print of barcode using Serial 1 or Serial 2 may cause an ink blur. To avoid the ink blur, widen the narrow bar width when designing the barcode layout.

Also, drop the print speed when rotating and printing with Serial 1 or Serial 2 for better performance.

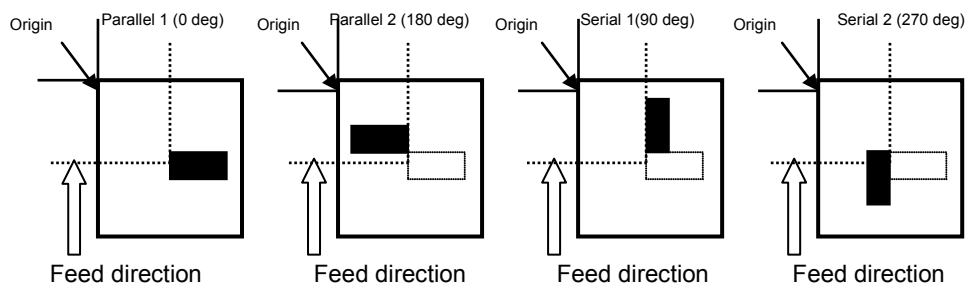

[Valid commands]

Font	<X20>	<X21>	<X22>	<X23>	<X24>	<K1>	<K2>	<K3>	<K4>	<K5>
	<K8>	<K9>	<k1>	<k2>	<k3>	<k4>	<k5>	<k8>	<k9>	<RD>
	<OA>	<OB>	<\$=>							
Barcode		<BC>	<BG>	<BI>	<BZ>	<D>	<D><d>	<BD>	<BT>	<BW>
	<BF>	<BL>	<BL><d>	<BM>						
2D code	<2D10>	<2D12>	<2D20>	<2D30>	<2D31>	<2D32>	<2D33>	<2D50>		
Composite symbol	<EU>									
Graphic	<G>	<GM>								
System	<E>									
Modification	<RF>	<(>								
Memory card	<GR>	<GC>								

7.6 Modification			
Sequential Number			ESC+F
Hex code	ESC <1B> ₁₆	F <41> ₁₆	Parameter aaaabcccc(,dd,ee,f)
Initial value	dd=8,ee=0,f=0		
Validity and valid duration of command	When the power switch is off	The set parameter is not maintained.	
	Validity in a job	The set parameter becomes invalid.	
	Validity after a job	The set parameter becomes invalid.	

[Function]

Specifies this command prior to the data designation commands (e.g. font, barcode) and executes the print of sequential numbering for specified data.

[Format]

<F>aaaabcccc (,dd,ee,f)

• Parameter

- a [Reprint using the same data] = 1 to 9999
- b [Plus or minus symbol] = + (for increments)
= - (for decrements)
- c [Value of step for sequence] = 1 to 9999
- d [Sequential numbering digit quantity] = 1 to 99 (If digits are left out, the default is 8)
- e [Number of digits free from sequential numbering starting with the right most position] = 0 to 99 (If digits are left out, the default is 0)
- f [Decimal/Hexadecimal sequential numbering] = 0: Decimal count (If digits are left out, the default is 0)
1: Hexadecimal

[Example] Reprint using the same data: 1, Plus or minus symbol: +
Value of step for sequence: 1, Sequential numbering digit quantity: 5
Number of digits free from sequential numbering: 0

```
<A>
<V>100<H>100<P>2<L>0202
<F>1+1,5,0<X21>,10000
<Q>2
<Z>
```

[Note]

1. Up to eight different sequential fields can be specified per format.
2. The print data right after the <F> command is the initial value of sequential numbering.
3. For sequential numbered data, specify the digits larger than that of [Sequential numbering digit quantity]. If not, the sequential numbering may not be executed properly.
4. The Reverse Image <> command cannot be used for sequential numbered data.
5. The Linefeed <E> command is not available for this command.

[Valid commands]

Font	<X20>	<X21>	<X22>	<X23>	<X24>	<RD>	<OA>	<OB>	<\$=>	
Barcode		<BC>	<BG>	<BI>	<BZ>	<D>	<D><d>	<BD>	<BT>	<BW>
	<BF>	<BL>	<BL><d>	<BM>						
Composite code	<EU>									

7.7 Modification

Print of Lines and Boxes	ESC+FW
---------------------------------	---------------

Hex code	ESC	FW	Parameter
	<1B> ₁₆	<46> ₁₆ <57> ₁₆	Lines aabccccPeeeeeeee Boxes aabbVccccHddddPeeeeeeee
Initial value	None		

Validity and valid duration of command	When the power switch is off	The set parameter is not maintained.
	Validity in a job	The set parameter becomes invalid.
	Validity after a job	The set parameter becomes invalid.

[Function]

Prints horizontal/vertical lines and boxes.

[Format]

<FW> aabccccPeeeeeeee Print of lines

• Parameter

a	[Line width]	=	02 to 99 dots
b	[Line orientation]	=	H : Horizontal direction V : Vertical direction
c	[Line length]	=	Refer to the table below
e	[Line pattern]	=	01 to FFFFFFFF

<FW> aabbVccccHddddPeeeeeeee Print of boxes

• Parameter

a	[Vertical line width]	=	02 to 99 dots
b	[Horizontal line width]	=	02 to 99 dots
c	[Vertical line length]	=	Refer to the table below
d	[Horizontal line length]	=	Refer to the table below
e	[Line pattern]	=	01 to FFFFFFFF

[Example]

Lines: Line width: 4, Horizontal direction, Line length: 400, Line pattern: F0F0F0F0
Boxes: V. line width: 8, H. line width: 8, V. line length: 300, H. line length: 400, Line pattern: F0F0F0F0

```
<A>
<V>100<H>200<FW>04H400PF0F0F0F0
<V>300<H>200<FW>0808V300H400PF0F0F0F0
<Q>2
<Z>
```

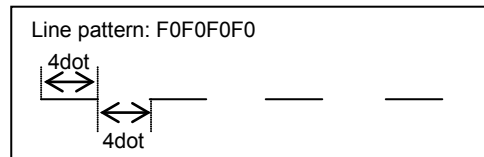

[Note]

1. If the print start position is outside of the printable area, printing will not be performed due to command error.
2. Set the horizontal line width to 02 dots or higher to make the width of horizontal line wider than 0.166mm.

Model	Line width
HR212	02 dots or more
HR224	04 dots or more

3. If setting the vertical line width wider, it will be widened to the right side against media feed direction. If setting the horizontal line width wider, it will be widened to the lower side against media feed direction.
4. If setting the line width of box wider, it will be widened to the inside box.
5. Specify 8-digit pattern for line pattern. (1 digit = 4 bit, 1 bit = 1 dot)
6. If the line pattern is less than 8 digits, generate the 8-digit data using the specified data repeatedly.
Example) By specifying the liner pattern "F0C", the line pattern of "F0CF0CF0" will be generated.

[Validity]

Model	Validity in dots	
	Vertical line length	Horizontal line length
HR212	1 to 2400	1 to 672
HR224	1 to 4800	1 to 1344

7.8 Modification

Print of Circles

ESC+FC

HEX code	ESC	FC	Parameter
	<1B> ₁₆	<46> ₁₆ <43> ₁₆	,aaa,bbb(,c,d)
Initial value	c=0, d=0		

Validity and valid duration of command	When the power switch is off	The set parameter is not maintained.
	Validity within item	The set parameter becomes invalid.
	Validity after a job	The set parameter becomes invalid.

[Function]

Specifies the printing of circles.

[Format]

<FC>,aaa,bbb(,c,d)

•Parameter

- a [Radius] = See the table below
- b [Line width] = See the table below
- c [Section number] = 0 to 8 (Omissible. If digit is left out, the default is 0)
For more details, see the section number below.
- d [Pattern] = 0 to 3 (Omissible. If digit is left out, the default is 0)
 - 0: Solid black line
 - 1: Gray 1
 - 2: Gray 2
 - 3: Gray 3

•Section number

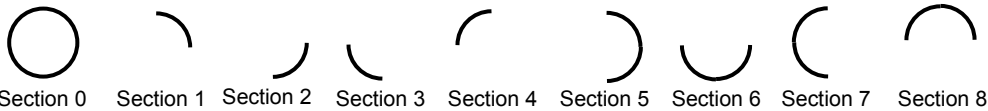

[Example] Solid line circle of 100 dots in radius, 8 dots in line width.

```
<A>
<V>100<H>200<FC>,100,8,0,0
<Q>2
<Z>
```

[Note]

- When a sectional number value is outside of the range, it will be processed as "0". (Command error will not occur)
- When the pattern designation value is outside of the range, it will be processed as "0". (Command error will not occur)
- When the print start position is outside of the printable area, printing will not occur due to command error.
- This command sets the base reference point to the center of a circle.

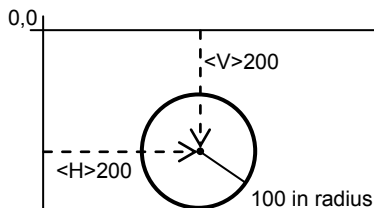

- This command can be registered to the format.
- If setting the line width wider, it will be widened to the inside circle.

[Validity]

Model	Validity in dots	
	Radius	Line width
HR212	5 to 336	1 to 336
HR224	5 to 672	1 to 672

7.9 Modification

Print of Triangles		ESC+FT	
HEX code	ESC <1B> ₁₆	FT <46> ₁₆ <54> ₁₆	Parameter ,aaaa,bbbb(,cccc,d)
Initial value	d=0		

Validity and valid duration of command	When the power switch is off	The set parameter is not maintained.
	Validity in a job	The set parameter becomes invalid.
	Validity after a job	The set parameter becomes invalid.

[Function]

Specifies the printing of triangles.

[Format]

<FT>,aaaa,bbbb(,cccc,d)

•Parameter

- a [Side length] = See the table below
- b [Line width] = See the table below
- c [Base length] = See the table below
(Omissible. If digits are left out, its value will be equal to the length of sides)
- d [Pattern] = 0 to 3 (Omissible. If digit is left out, the default is 0)
 - 0: Solid black line
 - 1: Gray 1
 - 2: Gray 2
 - 3: Gray 3

[Example] Side length: 100 dots, Line width: 8 dots, Base length: 100 dots

```
<A>
<V>100<H>200<FT>,100,8,100,0
<Q>2
<Z>
```

[Note]

- When the patten designation value is outside of the range, it will be processed as "0". (Command error will not occur)
- When the print start position is outside of the printable area, printing will not be performed due to command error.
- When the length of base length is not equal to the length of sides, printing will not occur due to command error.
- This command sets the base reference point to the apex of the triangle.

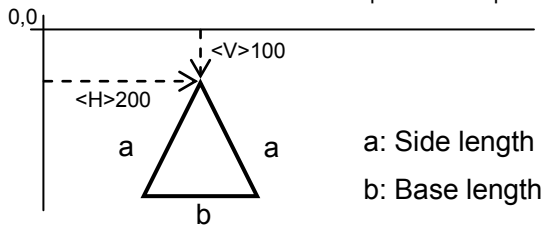

- This command can be registered to the format.
- If setting the line width, it will be widened to the inside triangle.
- Setting an odd number to the base length, 1 will be added to the base length automatically.

[Validity]

Model	Validity in dots		
	Side length	Line width	Base length
HR212	10 to 2412	1 to 1500	10 to 672
HR224	10 to 4824	1 to 3000	10 to 1344

7.10 Modification

Reverse Image		ESC+(
HEX code	ESC <1B> ₁₆	(<28> ₁₆	Parameter aaaa,bbbb
Default setting	None		

Validity and valid duration of command	When the power switch is off	The set parameter is not maintained.
	Validity in a job	The set parameter becomes invalid.
	Validity after a job	The set parameter becomes invalid.

[Function]

Reverses an image area from black to white and vice versa.

[Format]

<(>aaaa,bbbb

• Parameter

- a [Horizontal length in dots of reverse image area] = See the table below.
- b [Vertical height in dots of reverse image area] = See the table below.

[Example] Horizontal length in dots of reverse image area: 200, Vertical height in dots of reverse image area: 70

```
<A>
<V>60<H>70<P>2<L>0202<X21>,ABC
<V>60<H>70<(>200,70
<Q>2
<Z>
```

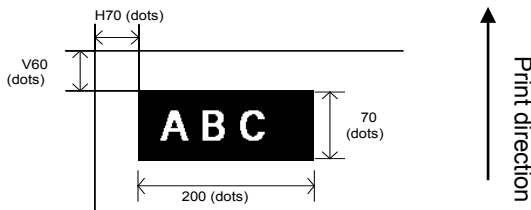

[Note]

- To execute this command, specify it after the data string to be reversed. If specifying this command prior to the data string to be reversed, it will be printed as all black.
- As for the print start position, place the Horizontal Print Position <H> and the Vertical Print Position <V> commands prior to this command.
- When the print start position is outside of the printable area, printing will not be performed due to command error.

[Tip]

- Keep the black print area under 30% of overall label.

[Validity]

Model	Validity in dots	
	Reverse image area in vertical direction	Reverse image area in horizontal direction
HR212	8 to 1200	8 to 672
HR224	8 to 2400	8 to 1344

7.11 Modification

Kanji code		ESC+KC	
HEX code	ESC <1B> ₁₆	KC <4B> ₁₆ <43> ₁₆	Parameter a
Initial value	a=0		

Validity and valid duration of command	When the power switch is off	The set parameter is not maintained.
	Validity in a job	The set parameter is valid until a new command is specified.
	Validity after a job	The set parameter becomes the initial value at the next item <A>.

[Function]

Specifies Kanji code.

Kanji code can be set by the printer setting. The Kanji Code <KC> command can change the Kanji code type temporarily.

[Format]

<KC>a

• Parameter

a	[Kanji code selection]	=	0	:	JIS code
			1	:	Shift JIS code
			2	:	Unicode

[Example 1] For Shift JIS code

```
<A>
<KC>1
<V>100<H>200<P>2<L>0202
<K1>H81698A94816A83548367815B
<Q>2
<Z>
```

[Example 2] For JIS code

```
<A>
<KC>0
<V>100<H>200<P>2<L>0202
<K1>H214A3374214B25352548213C
<Q>2
<Z>
```

[Example 3] ForUnicode

```
<A>
<KC>2
<V>100<H>200<P>2<L>0202
<K1>HFF08682AFF0930B530C830FC
<Q>2
<Z>
```

[Note]

1. It is not necessary to use this command in usual printing operation.
2. To set Shift JIS code to the initial value, set it by the printer setting.
3. This command can be used multiple times within a single item.
4. JIS code cannot be used when the printer has Ryobi font (JIS X 0213-compliant).

7.12 Modification

Store Form Overlay		ESC+&	
HEX code	ESC <1B> ₁₆	& <26> ₁₆	Parameter (aab~b)
Initial value	None		

Validity and valid duration of command	When the power switch is off	The set command is not maintained.
	Validity in a job	The set command is valid until a new command is specified.
	Validity after a job	The set command is valid until a new command is specified.

[Function]

Stores a label image in the volatile form overlay memory.

[Format]

<&>(aab~b)

- Parameter
- a [Registration key] = 01 to 99 (Omissible)
- b [Comment] = Max. 16 bytes (Omissible)

[Example]

```
<A>
<V>100<H>50<FW>1010V800H350
<V>100<H>50<FW>0505V760H310
<V>150<H>100<X23>,0MODEL
<&>01DATA1
<Z>
```

[Note]

1. This command stores fixed print contents to the printer and then, the Recall Form Overlay </> command combines the contents with drawing of general data to print out.
2. Place this command at the end of data string that is to be stored. Valid area for storing drawing to the form overlay memory is equal to the printable area of the printer.
3. Only one label image can be stored with this command. As for registration key, use random code within the range of 1 to 99.
4. To change the stored data, specify the Clear Form Overlay <*>& command, and then store new data.
5. Invoke stored data by the Recall Form Overlay </> command.
6. When specifying the Media Size <A1> command, it will be extracted in the specified area.

[Valid commands]

Print position	<V>	<H>								
Font	<X20>	<X21>	<X22>	<X23>	<X24>	<K1>	<K2>	<K3>	<K4>	<K5>
	<K8>	<K9>	<k1>	<k2>	<k3>	<k4>	<k5>	<k8>	<k9>	<\$=>
	<OA>	<OB>								
Barcode		<BC>	<BG>	<BI>	<BZ>	<D>	<D><d>	<BD>	<BT>	<BW>
	<BF>	<BL>	<BL><d>	<BM>						
2D code	<2D10>	<2D12>	<2D20>	<2D30>	<2D31>	<2D32>	<2D33>	<2D50>		
Composite code	<EU>									
Modification	<WD>	<FW>	<(>	<RF>	<FC>	<FT>				
Graphic	<G>	<GM>								

7.13 Modification

Recall Form Overlay	ESC+/ /
----------------------------	--------------------

HEX code	ESC <1B> ₁₆	/ <2F> ₁₆	Parameter (aa)
Initial value	None		

Validity and valid duration of command	When the power switch is off	The set command is not maintained.
	Validity in a job	The set command is valid until a new command is specified.
	Validity after a job	The set command is valid until a new command is specified.

[Function]

Recalls the label image from the form overlay memory for printing.

[Format]

</>(aa)

●Parameter

a [Registration key] = 01 to 99 (Omissible)

[Example]

<A>

</>01

<V>200<H>100<P>0<\$>B,100,100,6

<\$=>SATOPRINTER

<V>720<H>150102100*95000012345*

<Q>2

<Z>

[Note]

1. This command recalls the data stored by the Store Form Overlay <&> command for printing.
2. When detecting this command in general print data, this data will be printed with the drawing stored in form overlay memory.

7.14 Modification

Partial Edit		ESC+0	
HEX code	ESC	0	Parameter
	<1B> ₁₆	<30> ₁₆	None
Initial value	None		
Validity and valid duration of command	When the power switch is off	The set command is not maintained.	
	Validity in a job	The set command becomes invalid.	
	Validity after a job	The set command becomes invalid.	

[Function]

Replaces a specified area of the previous label with new data.

[Format]

<0>

[Example] Print data [DEF] is modified into [123]

```

<A>
<V>100<H>200<P>2<L>0202<X22>,ABC
<V>200<H>200<P>2<L>0202<X22>,DEF
<Q>1
<Z>
    } 1st data

<A>
<0>
<V>200<H>200<P>2<L>0202<X22>,123
<Q>1
<Z>
    } 2nd data
  
```

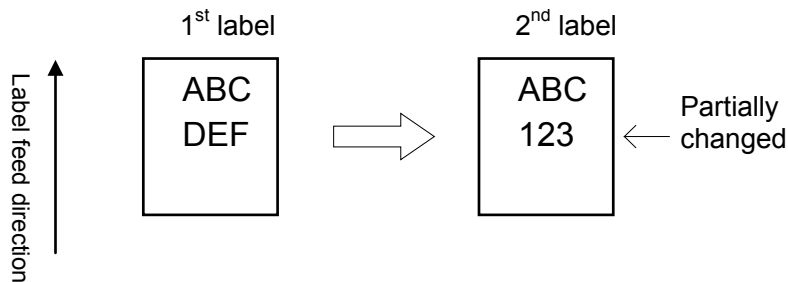

[Note]

1. Use this command to edit only one part of the previous print data.
2. Use this command to recall the previous print data for partial editing and printing. Specify the print position to be changed in the previous data before sending the data to be replaced.
3. Specified area in the previous data will be cleared.
4. If the Rotation (Fixed Base Reference Point) <%> command is placed in the specified editing portion, keep this command for partial editing.
5. Use this command with fixed proportional pitch, same font and same digit number.

7.15 Modification

Partial Copy		ESC+WD	
---------------------	--	---------------	--

HEX code	ESC	WD	Parameter
	<1B> ₁₆	<57> ₁₆ <44> ₁₆	VaaaaHbbbbYccccXdddd
Initial value	None		

Validity and valid duration of command	When the power switch is off	The set parameter is not maintained.
	Validity in a job	The set parameter becomes invalid.
	Validity after a job	The set parameter becomes invalid.

[Function]

Copies an image from one location to another on the same label.

[Format]

<WD>VaaaaHbbbbYccccXdddd

• Parameter

- a [Vertical position of the top left corner of the area] = See the table below.
- b [Horizontal position of the top left corner of the area] = See the table below.
- c [Vertical length of the image area to be copied] = See the table below.
- d [Horizontal length of the image area to be copied] = See the table below.

[Example] Vertical position of the top left corner of the area: 50, Horizontal position of the top left corner of the area: 50
 Vertical length of the image area to be copied: 200, Horizontal length of the image area to be copied: 400

```
<A>
<V>50<H>50<P>2<L>0202<X21>,ABCD
<V>300<H>100<WD>V50H50Y200X400
<Q>2
<Z>
```

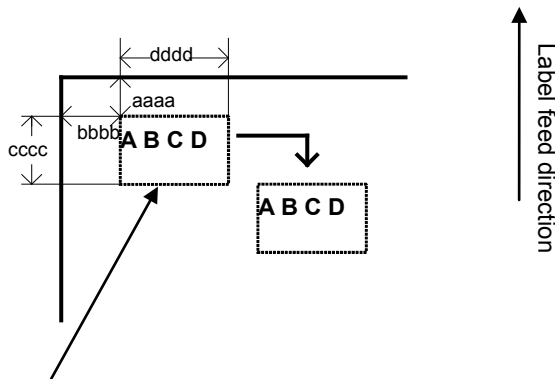

The dotted line indicates the area to be copied.
 "ABCD" will be printed.

[Note]

- To locate the destination of copy, specify the Vertical Print Position <V> and the Horizontal Print Position <H> commands prior to this command.
- Position of the new target area must not be inside the original image.
- If the print start position of copy area is outside of the printable area, printing will not be performed due to command error.

[Valid range]

Model	Validity in dots	
	Horizontal position of the top left corner of the area Horizontal length of the image area to be copied	Vertical position of the top left corner of the area Vertical length of the image area to be copied
HR212	1 to 672	1 to 1200
HR224	1 to 1344	1 to 2400

7.16 Modification

Recall and Print of Font & Logo		ESC+RF	
HEX code	ESC <1B> ₁₆	RF <52> ₁₆ <46> ₁₆	Parameter aabbbb, n~n
Initial value	None		

Validity and valid duration of command	When the power switch is off	The set parameter is not maintained.
	Validity in a job	The set parameter becomes invalid.
	Validity after a job	The set parameter becomes invalid.

[Function]

Calls and prints fonts and logos downloaded by the exclusive tools stored in the accessory CD-ROM.

[Format]

<RF>aabbbb,n~n

•Parameter

a	[Font ID number]	= 01 to 99
b	[Print digit]	= 1 to 9999
n	[Print data]	= Data

[Example 1] When [AB] is printed in one-byte character with this command [Font ID number: 01, Print digit: 4]
(Unicode A: <0041>₁₆, B: <0042>₁₆)

```
<A>
<PS>
<V>100<H>100<L>0101
<RF>010004,<4100>16<4200>16
<Z>
```

[Example 2] When calling and printing logos [Font ID number: 02, Print digit: 2]

```
<A>
<V>100<H>100<L>0101<RF>020002,<6B82>16
<Z>
```

[Note]

- For the print data, specify the value of Unicode which high and low bytes are swapped.
- When calling and printing a log, specify [Print digit: 0002], [Print data: <6B82>₁₆].
(Note that <6B82>₁₆ is the high and low bytes swapped value of Shift JIS code <826B>₁₆ of L)
- Use [Font design tool], [Logo design tool] and [Download tool] on the accompanied CD-ROM to register/delete fonts and logos.
- As for the font ID number corresponded to downloaded font and logo, refer to the [Maintenance] menu of [Font design tool], [Logo design tool] or [Download tool] → [Download logo/font maintenance] to select the [Font ID number] in the dialog.
- As for the use of each tool, refer to [Font design tool manual], [Logo design manual] and [Download tool manual] in the accessory CD-ROM.

7.17 Modification

Journal Print		ESC+J	
HEX code	ESC <1B> ₁₆	J <4A> ₁₆	Parameter a~a+CR<0D> ₁₆
Initial value	None		
Validity and valid duration of command	When the power switch is off	The set parameter is not maintained.	
	Validity in a job	The set parameter becomes invalid.	
	Validity after a job	The set parameter becomes invalid.	

[Function]

Specifies journal printing which prints text in a line by line format on a label.

[Format]

- <J>a~aCR
- Parameter
 - a [Text line] = Print data
 - CR [Control code (0DH)]

[Example]

```
<A>
<J>
ABCD+CR
EFGH+CR
<Z>
```

[Note]

1. By specifying this command, journal printing will be initiated from the point of H2 and V2.
2. The character pitch is 2 dots and the line gap is 16 dots.
3. The print data is printed in S font with a character expansion of 2×2.
4. This command cannot be used in combination with other commands except the Repeat <C> command and the Reverse Image <(> command.

7.18 Modification

Mirror Image		ESC+RM	
HEX code	ESC <1B> ₁₆	RM <52> ₁₆ <4D> ₁₆	Parameter aaa,bbbb
Initial value	None		

Validity and valid duration of command	When the power switch is off	The set parameter is not maintained.
	Validity in a job	The set parameter becomes invalid.
	Validity after a job	The set parameter becomes invalid.

[Function]

Creates the mirror image of print data.

[Format]

<H>hhh<V>vvv<RM>aaa,bbbb

- Parameter
 - h [Horizontal position of the top left corner of the area to be mirrored] = See the table below.
 - v [Vertical position of the top left corner of the area to be mirrored] = See the table below.
 - a [Horizontal length in dots of image area to be mirrored] = See the table below.
 - b [Vertical length in dots of image area to be mirrored] = See the table below.

[Example 1] Specifying the image area to be mirrored.

```
<A>
<H>100<V>200<X21>,12345
<H>100<V>200<RM>0200.0080
<Q>1
<Z>
```

[Example 2] Not specifying the image area to be mirrored.

```
<A>
<H>100<V>200<X21>,12345
<RM>
<Z>
```

[Note]

1. If the parameter [aaa,bbbb] is not specified in the command, all data preceding the command will be mirrored.
2. Any data outside the printable area is not mirrored.
3. Any print job containing the command and without any print data will be treated as a command error.
4. This command cannot be used with commands requiring re-editing of the print area, such as Sequential Number <F> and Partial Copy <WD>. Also, data registration commands such as Store Graphic <GI> and Store Format <YS> cannot be used together.
5. This command should not be specified more than once in any single job.

[Start position of image area to be mirrored]

Model	Validity in dots	
	Horizontal position of the top left corner of the area to be mirrored	Vertical position of the top left corner of the area to be mirrored
HR212	1 to 672	1 to 1200
HR224	1 to 1344	1 to 2400

[Image area to be mirrored]

Model	Validity in dots	
	Horizontal length in dots of image area to be mirrored	Vertical length in dots of image area to be mirrored
HR212	8 to 672	8 to 1200
HR224	8 to 1344	8 to 2400

7.19 Modification

Clockwise Circular Arc		ESC+%A	
HEX code	ESC <1B> ₁₆	%A <25> ₁₆ <41> ₁₆	Parameter aaa,bbb,c
Initial value	None		

Validity and valid duration of command	When the power switch is off	The set parameter is not maintained.
	Validity in a job	The set parameter is valid until a new command is specified or until the Rotation <%> command is specified.
	Validity after a job	The set parameter becomes the initial value at the next item <A>.

[Function]

Rotates and prints the font in a clockwise direction from the specified arbitrary angle and radius.

[Format]

<%A>aaa,bbb,c

- Parameter
 - a [Angle] = 0 to 359°
 - b [Radius] = See the table below
 - c [Drawing direction] = 0 : Clockwise
1 : Counterclockwise

[Example 1] Angle: 0°, Radius: 300 dots, Drawing direction: 0 (Clockwise)

```
<A>
<%A>0.300.0
<V>400<H>400<P>2<RD>A00,P10,P10,ABCDE
<Q>
<Z>
```

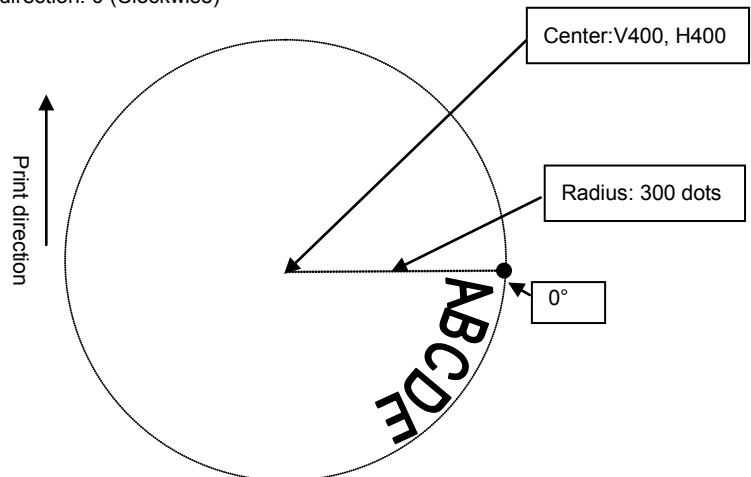

[Example 2] Angle: 270°, Radius: 300 dots, Drawing direction: 1 (Counterclockwise)

```
<A>
<%A>270.300.1
<V>400<H>400<P>2<RD>A00,P10,P10,ABCDE
<Q>2
<Z>
```

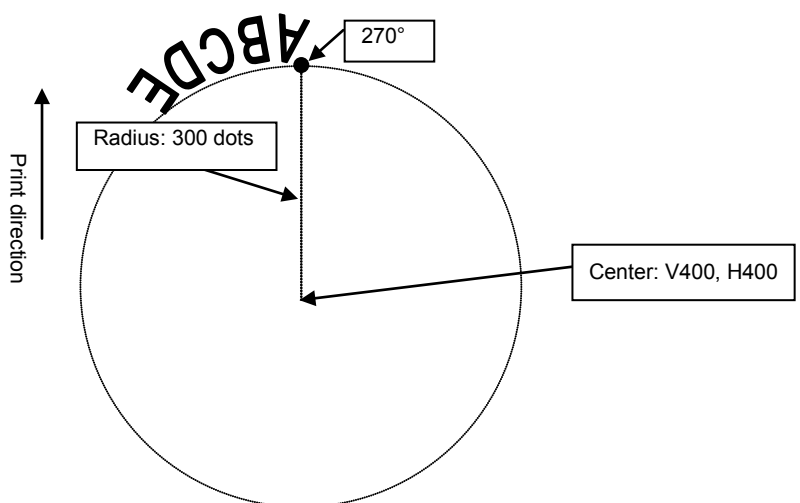

[Note]

1. Vertical Print Position <V> command and Horizontal Print Position <H> command will be set to the center of a circle.
2. If setting the value of parameter a to 360 or more, a command error occurs.
3. Print angle may affect font shape. Be sure to check the print result for better performance.
4. If the font height and width specified by the Character Expansion <L> command are larger than the specified radius, this font may not be printed properly.
5. To terminate this command and to perform print job normally, specify the Rotation (Fixed Base Reference Point) <%> command, the Rotation (Base Reference Point Shift) <R> command or the Normal Print Direction <N> command.
6. When the rotated text is outside the printable area, the exceeded portion cannot be printed.
7. To use the CG Font <RD> command, the maximum V and H values are 99 dots.
(HR224: Max. 11 points, HR212: Max. 23 points)
8. If the print data is outside the printable area, the exceeded portion of print data cannot be printed.

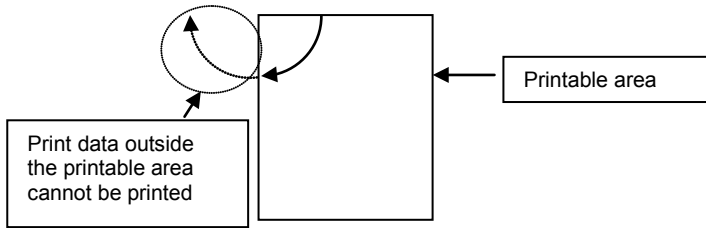

9. The print data is arranged in a circular pattern. Therefore, the print data will be overlapped when it is longer than the circular arc.
10. Specifying this command with the Sequential Number <F> command causes a command error.

[Initial value and validity of parameter]

Model	Validity in dots
HR212	1 to 672
HR224	1 to 1344

[Valid commands]

Modification	<P>	<L>	<%>	<&>	</>	<&S>	<&R>	<YS>	<YR>	<PS>	<PR>
Font	<RD>	<X20>	<X21>	<X22>	<X23>	<X24>	<OA>	<OB>			

8. Font Command

8.1 Font			
X20 Font (Basic size 5x9 dots)			ESC+X20
HEX code	ESC <1B> ₁₆	X20 <58> ₁₆ <32> ₁₆ <30> ₁₆	Parameter
Initial value	None		
Validity and valid duration of command	When the power switch is off	The set parameter is not maintained.	
	Validity in a job	The set parameter becomes invalid.	
	Validity after a job	The set parameter becomes invalid.	

[Function]

Specifies X20 font consists of W5 x H9 dots.

[Format]

<X20>,n~n

• Parameter

n [Print data] = Data

[Example]

```
<A>
<V>100<H>200<P>2<L>0304<X20>.ABCDE
<Q>2
<Z>
```

[Note]

1. X20 font for fixed pitch only.

[Valid commands]

Print position	<V>	<H>								
Barcode	<D><d>									
Modification	<P>	<L>	<%>	<F>	<&>	</>	<O>	<WD>	<%A>	

X20 font character set

Basic font size W5 x H9 dots.

	0	1	2	3	4	5	6	7	8	9	A	B	C	D	E	F
0				0	@	P		p				-	ヲ	ヰ		
1			!	1	A	Q	a	q				ア	チ	ム		
2			"	2	B	R	b	r				イ	ツ	ヌ		
3			#	3	C	S	c	s				ウ	テ	モ		
4			\$	4	D	T	d	t				エ	ト	セ		
5			%	5	E	U	e	u			.	オ	フ	ユ		
6			&	6	F	V	f	v			ヨ	カ	ニ	ヨ		
7			'	7	G	W	g	w				キ	ヌ	ラ		
8			<	8	H	X	h	x				ク	ネ	リ		
9			>	9	I	Y	i	y				ケ	ノ	ル		
A			*	:	J	Z	j	z				コ	ハ	レ		
B			+	;	K	φ	k	-				サ	ヒ	ロ		
C			,	<	L	¥	l	-				シ	フ	ワ		
D			-	=	M		m					ス	ヘ	ン		
E			.	>	N		n	!				セ	ホ	ハ		
F			/	?	O		o					ソ	マ	◇		

8.2 Font

X21 Font (Basic size 17x17 dots)

ESC+X21

HEX code	ESC	X21	Parameter
	<1B> ₁₆	<58> ₁₆ <32> ₁₆ <31> ₁₆	,n~n
Initial value	None		

Validity and valid duration of command	When the power switch is off	The set parameter is not maintained.
	Validity in a job	The set parameter becomes invalid.
	Validity after a job	The set parameter becomes invalid.

[Function]

Specifies X21 font consists of W17 x H17 dots..

[Format]

<X21>,n~n

- Parameter

n [Print data] = Data

[Example]

<A>
<V>100<H>200<P>2<L>0304<X21>.ABCDE
<Q>2
<Z>

[Note]

1. X21 font allows the setting of fixed pitch or proportional pitch.
2. Select fixed pitch or proportional pitch by the command or through the printer LCD.

[Valid commands]

Print position	<V>	<H>								
Barcode	<D><d>									
Modification	<P>	<L>	<%>	<F>	<&>	</>	<O>	<WD>	<PS>	<PR>
	<%A>									

X21 font character set

Basic font size W17 x H17 dots.

	0	1	2	3	4	5	6	7	8	9	A	B	C	D	E	F
0				0	@	P	'	p				一	夕	ミ		
1			!	1	A	Q	a	q			。	ア	チ	ム		
2			"	2	B	R	b	r			「	イ	ツ	メ		
3			#	3	C	S	c	s			」	ウ	テ	モ		
4			\$	4	D	T	d	t			、	エ	ト	ヤ		
5			%	5	E	U	e	u			・	オ	ナ	ユ		
6			&	6	F	V	f	v			ヲ	カ	ニ	ヨ		
7			'	7	G	W	g	w			ア	キ	ヌ	ラ		
8			(8	H	X	h	x			イ	ク	ネ	リ		
9)	9	I	Y	i	y			ウ	ケ	ノ	ル		
A			*	:	J	Z	j	z			エ	コ	ハ	レ		
B			+	;	K	[k	{			オ	サ	ヒ	ロ		
C			,	<	L	¥	l	!			ヤ	シ	フ	ワ		
D			-	=	M]	m	}			ユ	ス	ヘ	ソ		
E			.	>	N	^	n	~			ヨ	セ	ホ	°		
F			/	?	O	_	o				ッ	ソ	マ	°		

8.3 Font

X22 Font (Basic size 24x24 dots)	ESC+X22
---	----------------

HEX code	ESC	X22	Parameter
	<1B> ₁₆	<58> ₁₆ <32> ₁₆ <32> ₁₆	,n~n
Initial value	None		

Validity and valid duration of command	When the power switch is off	The set parameter is not maintained.
	Validity in a job	The set parameter becomes invalid.
	Validity after a job	The set parameter becomes invalid.

[Function]

Specifies X22 font consists of W24 x H24 dots.

[Format]

<X22>,n~n

• Parameter

n [Print data] = Data

[Example]

<A>
 <V>100<H>200<P>2<L>0304<X22>.ABCDE
 <Q>2
 <Z>

[Note]

1. The X22 font allows the setting of fixed pitch or proportional pitch.
2. Select fixed pitch or proportional pitch by the command or through the printer LCD.

[Valid commands]

Print position	<V>	<H>								
Barcode	<D><d>									
Modification	<P>	<L>	<%>	<F>	<&>	</>	<O>	<WD>	<PS>	<PR>
	<%A>									

X22 font character set

Basic font size W24 x H24 dots.

	0	1	2	3	4	5	6	7	8	9	A	B	C	D	E	F
0				0	@	P	`	p				—	夕	ミ		
1			!	1	A	Q	a	q			.	ア	チ	ム		
2			”	2	B	R	b	r			「	イ	ツ	メ		
3			#	3	C	S	c	s			」	ウ	テ	モ		
4			\$	4	D	T	d	t			,	エ	ト	ヤ		
5			%	5	E	U	e	u			・	オ	ナ	ユ		
6			&	6	F	V	f	v			ヲ	カ	ニ	ヨ		
7			'	7	G	W	g	w			ア	キ	ヌ	ラ		
8			(8	H	X	h	x			イ	ク	ネ	リ		
9)	9	I	Y	i	y			ウ	ケ	ノ	ル		
A			*	:	J	Z	j	z			エ	コ	ハ	レ		
B			+	;	K	[k	{			オ	サ	ヒ	ロ		
C			,	<	L	¥	l	!			ヤ	シ	フ	ワ		
D			-	=	M]	m	}			ユ	ス	ヘ	ン		
E			.	>	N	^	n	~			ヨ	セ	ホ	´		
F			/	?	O	_	o				ツ	ソ	マ	°		

8.4 Font

X23 Font (Basic size 48x48 dots)

ESC+X23

HEX code	ESC	X23	Parameter
	<1B> ₁₆	<58> ₁₆ <32> ₁₆ <33> ₁₆	,an~n
Initial value	None		

Validity and valid duration of command	When the power switch is off	The set parameter is not maintained.
	Validity in a job	The set parameter becomes invalid.
	Validity after a job	The set parameter becomes invalid.

[Function]

Specifies X23 font consists of W48 x H48 dots.

[Format]

<X23>,an~n

• Parameter

a	[Smoothing]	=	0	:	Smoothing OFF
			1	:	Smoothing ON
					(When the Character Expansion <L> command is set between 3 and 12)
n	[Print data]	=	Data		

[Example]

```
<A>
<V>100<H>200<P>2<L>0304<X23>.0ABCDE
<Q>2
<Z>
```

[Note]

1. X23 font allows the setting of fixed pitch or proportional pitch.
2. Select fixed pitch or proportional pitch by the command or through the printer LCD.
3. Smoothing function is only effective if the Character Expansion <L> command is at least three times in each direction.

[Valid commands]

Print position	<V>	<H>								
Barcode	<D><d>									
Modification	<P>	<L>	<%>	<F>	<&>	</>	<O>	<WD>	<PS>	<PR>
	<%A>									

X23 font character set

Basic font size W48 x H48 dots.

	0	1	2	3	4	5	6	7	8	9	A	B	C	D	E	F
0			0	@	P	'	p					一	タ	ミ		
1		!	1	A	Q	a	q			。	ア	チ	ム			
2		"	2	B	R	b	r			「	イ	ツ	メ			
3		#	3	C	S	c	s			」	ウ	テ	モ			
4		\$	4	D	T	d	t			、	エ	ト	ヤ			
5		%	5	E	U	e	u			・	オ	ナ	ユ			
6		&	6	F	V	f	v			ヲ	カ	ニ	ヨ			
7		'	7	G	W	g	w			ア	キ	ヌ	ラ			
8		(8	H	X	h	x			イ	ク	ネ	リ			
9)	9	I	Y	i	y			ウ	ケ	ノ	ル			
A		*	:	J	Z	j	z			エ	コ	ハ	レ			
B		+	;	K	[k	{			オ	サ	ヒ	ロ			
C		,	<	L	¥	l	;			ヤ	シ	フ	ワ			
D		-	=	M]	m	}			ユ	ス	ヘ	ン			
E		.	>	N	^	n	~			ヨ	セ	ホ	°			
F		/	?	O	_	o				ツ	ソ	マ	°			

8.5 Font

X24 font (Basic size 48x48 dots)

ESC+X24

HEX code	ESC	X24	Parameter
	<1B> ₁₆	<58> ₁₆ <32> ₁₆ <34> ₁₆	,an~n
Initial value	None		

Validity and valid duration of command	When the power switch is off	The set parameter is not maintained.
	Validity in a job	The set parameter becomes invalid.
	Validity after a job	The set parameter becomes invalid.

[Function]

Specifies X24 font consists of W48 x H48 dots.

[Format]

<X24>,an~n

• Parameter

a [Smoothing] = 0 : Smoothing OFF
 1 : Smoothing ON
 (When the Character Expansion <L> command is set between 3 and 12)

n [Print data] = Data

[Example]

<A>
 <V>100<H>200<P>2<L>0304<X24>,0ABCDE
 <Q>2
 <Z>

[Note]

1. The X24 font allows the setting of a fixed pitch or the setting of a proportional pitch.
2. Select fixed pitch or proportional pitch by the command or through the printer LCD.
3. Smoothing function is only effective if the Character Expansion <L> command is at least three times in each direction.

[Valid commands]

Print position	<V>	<H>								
Barcode	<D><d>									
Modification	<P>	<L>	<%>	<F>	<&>	</>	<O>	<WD>	<PS>	<PR>
	<%A>									

X24 font character set

Basic font size W48 x H48 dots.

	0	1	2	3	4	5	6	7	8	9	A	B	C	D	E	F
0			0	@	P	'	p					一	夕	ミ		
1		!	1	A	Q	a	q			。	ア	チ	ム			
2		"	2	B	R	b	r				「	イ	ツ	メ		
3		#	3	C	S	c	s				」	ウ	テ	モ		
4		\$	4	D	T	d	t				、	エ	ト	ヤ		
5		%	5	E	U	e	u				・	オ	ナ	ユ		
6		&	6	F	V	f	v				ヲ	カ	ニ	ヨ		
7		'	7	G	W	g	w				ア	キ	ヌ	ラ		
8		(8	H	X	h	x				イ	ク	ネ	リ		
9)	9	I	Y	i	y				ウ	ケ	ノ	ル		
A		*	:	J	Z	j	z				エ	コ	ハ	レ		
B		+	;	K	[k	{				オ	サ	ヒ	ロ		
C		,	<	L	¥	l	;				ヤ	シ	フ	フ		
D		-	=	M]	m	}				ユ	ス	ヘ	ン		
E		.	>	N	^	n	~				ヨ	セ	ホ	°		
F		/	?	O	_	o					ツ	ソ	マ			

8.6 Font			
OCR-A Font			ESC+OA
HEX code	ESC <1B> ₁₆	OA <4F> ₁₆ <41> ₁₆	Parameter n~n
Initial value	None		
Validity and valid duration of command	When the power switch is off	The set parameter is not maintained.	
	Validity in a job	The set parameter becomes invalid.	
	Validity after a job	The set parameter becomes invalid.	

[Function]
Specifies OCR-A font.

[Format]
<OA>n~n
 • Parameter
 n [Print data] = Data

[Example]
 <A>
 <V>100<H>100<P>2<L>0202<OA>ABC
 <Q>2
 <Z>

[Font size table]

Printer model	Font size in dots
HR212	W22 x H33
HR224	W44 x H66

[Valid commands]

Print position	<V>	<H>							
Modification	<P>	<L>	<%>	<F>	<&>	</>	<O>	<WD>	<%A>
Barcode	<D><d>	<BL><d>							

OCR-A font character set

	0	1	2	3	4	5	6	7	8	9	A	B	C	D	E	F
0				0		P										
1				1	A	Q										
2				2	B	R										
3				3	C	S										
4			4	4	D	T										
5				5	E	U										
6				6	F	V										
7				7	G	W										
8				8	H	X										
9				9	I	Y										
A					J	Z										
B					K											
C					L											
D					M											
E			.	>	N											
F			/		o											

The print sample shown above is issued with a head density of 12 dots/mm, a font size of 22x33, and a expansion factor of 1 (vertical/horizontal).

8.7 Font

OCR-B Font		ESC+OB	
HEX code	ESC <1B> ₁₆	OB <4F> ₁₆ <42> ₁₆	Parameter n~n
Initial value	None		

Validity and valid duration of command	When the power switch is off	The set parameter is not maintained.
	Validity in a job	The set parameter becomes invalid.
	Validity after a job	The set parameter becomes invalid.

[Function]
Specifies OCR-B font.

[Format]
<OB>n~n
 • Parameter
 n [Print data] = Data

[Example]
 <A>
 <V>100<H>100<P>2<L>0202<OB>ABC
 <Q>2
 <Z>

[Font size table]

Printer model	Font size in dots
HR212	W30 x H36
HR224	W60 x H72

[Valid commands]

Print position	<V>	<H>							
Modification	<P>	<L>	<%>	<F>	<&>	</>	<0>	<WD>	<%A>
Barcode	<D><d>	<BL><d>							

OCR-B font character set

	0	1	2	3	4	5	6	7	8	9	A	B	C	D	E	F
0				0	@	P										
1			!	1	A	Q										
2			"	2	B	R										
3			#	3	C	S										
4			\$	4	D	T										
5			%	5	E	U										
6			&	6	F	V										
7			'	7	G	W										
8			(8	H	X										
9)	9	I	Y										
A			*	:	J	Z										
B			+	;	K	¥										
C			,	<	L	¥										
D			-	=	M											
E			.	>	N											
F			/	?	O											

8.8 Font

Outline Font Design	ESC+\$
----------------------------	---------------

HEX code	ESC	\$	Parameter
	<1B> ₁₆	<24> ₁₆	a,bbb,ccc,d
Initial value	a=A, bbb=50, ccc=50, d=0		

Validity and valid duration of command	When the power switch is off	The set parameter is not maintained.
	Validity in a job	The set parameter is valid until a new command is specified.
	Validity after a job	The set parameter becomes the initial value at the next item <A>.

[Function]

Specifies the font type, size and design of outline font.

[Format]

<\$>a,bbb,ccc,d

• Parameter

a	[Font type]	=	A	:	Helvetica Bold (Proportional)
			B	:	Helvetica Bold (Inter-character pitch fixed)
			K	:	Kanji specified by hexadecimal number *1
			L	:	Kanji specified by binary number *1
			K	:	Kanji (vertical writing) specified by hexadecimal number *1
			L	:	Kanji (vertical writing) specified by binary number *1
b	[Font width]	=	24 to 999 dots		
c	[Font height]	=	24 to 999 dots		
d	[Font design]	=	0	:	Normal font (Black)
			1	:	Outline font
			2	:	Gray font (Pattern 1)
			3	:	Gray font (Pattern 2)
			4	:	Gray font (Pattern 3)
			5	:	Shaded font
			6	:	Outline and shaded font
			7	:	Mirror image font
			8	:	Standard Italic font
			9	:	Outline, shaded, and Italic font

* Indicates Kanji outline font.

[Example] Font type: A, Font width: 100 dots, Font height: 100 dots, Font design: 1

```
<A>>
<V>>100<H>100<P>2
<$>A,100,100,1<=>OUTLINE FONT
<Q>2
<Z>
```

OUTLINE FONT

[Note]

1. Italic font is inclined 15-degree within font width specification
2. Specify this command after the Outline Font Print <=> command.
3. If specified dots in [Font design] are small, they may be unreadable.
4. Small font width and height may be unreadable.

[Valid commands]

Modification	<\$=>
--------------	-------

8.9 Font

Outline Font Print	ESC+\$=
---------------------------	----------------

HEX code	ESC <1B> ₁₆	\$= <24> ₁₆ <3D> ₁₆	Parameter n~n
Initial value	None		

Validity and valid duration of command	When the power switch is off	The set parameter is not maintained.
	Validity in a job	The set parameter becomes invalid.
	Validity after a job	The set parameter becomes invalid.

[Function]

Prints the outline font.

[Format]

<\$=>n~n

•Parameter

n [Print data] = Data

[Example]

Print data: OUTLINE FONT

<A>

<V>100<H>100<P>2

<\$>A,100,100,1<<\$=>OUTLINE FONT

OUTLINE FONT

<Q>2

<Z>

[Note]

1. Specify the Outline Font <\$> command prior to this command.
2. Font height specification includes ascender and descender areas. For proportional pitch, letter size width of outline font varies depending on the individual font.
3. Use the Character Pitch <P> command to specify font pitch.
4. Italic font is inclined 15-degree within font width specification. Font height specification includes ascender and descender areas.
5. If specified dots in [Font shape] are small, they may be unreadable.
6. If specifying small font width and height for the Outline Font <\$> command, some fonts may be unreadable.
7. Kanji code such as JIS, Shift JIS and Unicode are available for Kanji outline font. Kanji code can be set by the Kanji Code <KC> command or go to the character code of printer setting through the printer LCD display.

[Valid commands]

Print position	<V>	<H>								
Modification	<P>	<%>	<\$>	<F>						

8.10 Font			
CG Font			ESC+RD
HEX code	ESC <1B> ₁₆	RD <52> ₁₆ <44> ₁₆	Parameter abb,ccc,ddd,n~n
Initial value	None		
Validity and valid duration of command	When the power switch is off	The set parameter is not maintained.	
	Validity in a job	The set parameter becomes invalid.	
	Validity after a job	The set parameter becomes invalid.	

[Function]
Specifies the CG font type, font size and print data

[Format]
<RD>abb,ccc,ddd,n~n

- Parameter
 - a [Font type] = A [CG Times]
B [CG Triumvirate]
 - b [Font style] = 00 Fixed
 - c [Width] = 004 to 999 dots
P02 to P99 points
 - d [Height] = 004 to 999 dots
P02 to P99 points
 - n [Print data] = Data

[Example] Font type: CG Times, Width: 10 points, Height: 10 points
 <A>
 <V>100<H>100<P>2
<RD>A00,P10,P10,SATO
 <Q>2
 <Z>

- [Note]
1. Specify the font size in dots or points.
 2. The dot size may vary depending on the printer model. Refer to the table below.

[Dot size]

Printer model	Dot size
HR212	0.083mm
HR224	0.042mm

3. 1 point is 0.35mm.

[Valid commands]

Print position	<V>	<H>								
Modification	<P>	<%>	<F>	<PS>	<PR>	<%A>				

8.11 Font

16x16 Dots Horizontal Flow Kanji (JIS / Shift JIS / Unicode)		ESC+K1	
HEX code	ESC <1B> ₁₆	K1 <4B> ₁₆ <31> ₁₆	Parameter an~n
Initial value	None		

Validity and valid duration of command	When the power switch is off	The set parameter is not maintained.
	Validity in a job	The set parameter becomes invalid.
	Validity after a job	The set parameter becomes invalid.

[Function]

Specifies W16 x H16 dots horizontally written Kanji.

[Format]

<K1>an~n

• Parameter

- | | | | |
|---|------------------------|---|--|
| a | [Kanji selection mode] | = | H : Hexadecimal character
B : Binary code
I : Smoothing function by hexadecimal character
C : Smoothing function by binary code
J : Highlighting function by hexadecimal character
D : Highlighting function by binary code
K : Smoothing and highlighting functions by hexadecimal character
E : Smoothing and highlighting functions by binary code |
| n | [Data] | = | Refer to Kanji code table (JIS, Shift JIS, Unicode) |

[Example 1] HEX character of Shift JIS, Horizontal magnification: 3 times, Vertical magnification: 5 times

Data: (株) サトー
 <A>
 <V>100<H>200<P>2<L>0305
<K1>H81698A94816A83548367815B
 <Q>2
 <Z>

[Example 2] Binary code of JIS, Horizontal magnification: Twofold, Vertical magnification: 3 times, Data: (株) サトー

<A>
 <V>100<H>200<P>2<L>0203
<K1>B!J3t!K%5%H!<
 <Q>2
 <Z>

[Note]

- | | | |
|----------------------------------|---|--|
| 1. HEX character | = | Kanji Code 4 bytes ASCII / 1 Kanji character |
| 2. Binary code | = | Kanji Code 2 bytes / 1 Kanji character |
| 3. Smoothing functional range | = | Width and height : 3 to 12 times |
| 4. Highlighting functional range | = | Width and height : 1 to 5 times |

[Tip]

- In highlighting function, character width becomes wider based on the magnification ratio.
- Some characters may be unreadable when highlighting function is enabled.

[Valid commands]

Print position	<V>	<H>							
Modification	<P>	<L>	<%>	<&>	</>	<0>	<WD>		

8.12 Font

24 x 24 Dots Horizontal Flow Kanji (JIS / Shift JIS / Unicode)

ESC+K2

HEX code	ESC	K2	Parameter
	<1B> ₁₆	<4B> ₁₆ <32> ₁₆	an~n
Initial value	None		

Validity and valid duration of command	When the power switch is off	The set parameter is not maintained.
	Validity in a job	The set parameter becomes invalid.
	Validity after a job	The set parameter becomes invalid.

[Function]

Specifies W24 x H24 dots horizontally written Kanji.

[Format]

<K2>an~n

• Parameter

a	[Kanji selection mode]	=	H : Hexadecimal character B : Binary code I : Smoothing function by hexadecimal character C : Smoothing function by binary code J : Highlighting function by hexadecimal character D : Highlighting function by binary code K : Smoothing and highlighting functions by hexadecimal character E : Smoothing and highlighting functions by binary code
n	[Data]	=	Refer to Kanji code table (JIS, Shift JIS, Unicode)

[Example 1] HEX character of Shift JIS, Horizontal magnification: 3 times, Vertical magnification: 5 times

Data: (株) サトー
 <A>
 <V>100<H>200<P>2<L>0305
<K2>H81698A94816A83548367815B
 <Q>2
 <Z>

[Example 2] Binary code of JIS, Horizontal magnification: Twofold, Vertical magnification: 3 times, Data: (株) サトー

<A>
 <V>100<H>200<P>2<L>0203
<K2>B!J3t!K%5%H!<
 <Q>2
 <Z>

[Note]

1. HEX characters = Kanji Code 4 bytes ASCII / 1 Kanji character
2. Binary code = Kanji Code 2 bytes / 1 Kanji character
3. Smoothing functional range = Width and height : 3 to 12 times
4. Highlighting functional range = Width and height : 1 to 5 times

[Tip]

1. In highlighting function, character width becomes wider based on the magnification ratio.
2. Some characters may be unreadable when highlighting function is enabled.

[Valid commands]

Print position	<V>	<H>							
Modification	<P>	<L>	<%>	<&>	</>	<0>	<WD>		

8.13 Font

22 x 22 Dots Horizontal Flow Kanji (JIS / Shift JIS / Unicode)

ESC+K3

HEX code	ESC <1B> ₁₆	K3 <4B> ₁₆ <33> ₁₆	Parameter an~n
Initial value	None		

Validity and valid duration of command	When the power switch is off	The set parameter is not maintained.
	Validity in a job	The set parameter becomes invalid.
	Validity after a job	The set parameter becomes invalid.

[Function]

Specifies W22 x H22 dots horizontally written Kanji.

[Format]

<K3>an~n

• Parameter

a	[Kanji selection mode]	=	H : Hexadecimal character B : Binary code I : Smoothing function by hexadecimal character C : Smoothing function by binary code J : Highlighting function by hexadecimal character D : Highlighting function by binary code K : Smoothing and highlighting functions by hexadecimal character E : Smoothing and highlighting functions by binary code
n	[Data]	=	Refer to Kanji code table (JIS, Shift JIS, Unicode)

[Example 1] HEX characters of Shift JIS, Horizontal magnification: 3 times, Vertical magnification: 5 times

Data: (株) サトー

```
<A>
<V>100<H>200<P>2<L>0305
<K3>H81698A94816A83548367815B
<Q>2
<Z>
```

[Example 2] Binary code of JIS, Horizontal magnification: Twofold, Vertical magnification: 3 times, Data: (株) サトー

```
<A>
<V>100<H>200<P>2<L>0203
<K3>B!J3t!K%5%H!<
<Q>2
<Z>
```

[Note]

- | | | |
|----------------------------------|---|--|
| 1. HEX characters | = | Kanji Code 4 bytes ASCII / 1 Kanji character |
| 2. Binary code | = | Kanji Code 2 bytes / 1 Kanji character |
| 3. Smoothing functional range | = | Width and height : 3 to 12 times |
| 4. Highlighting functional range | = | Width and height : 1 to 5 times |

[Tip]

- In highlighting function, character width becomes wider based on the magnification ratio.
- Some characters may be unreadable when highlighting function is enabled.

[Valid commands]

Print position	<V>	<H>							
Modification	<P>	<L>	<%>	<&>	</>	<0>	<WD>		

8.14 Font

32 x 32 Dots Horizontal Flow Kanji (JIS / Shift JIS / Unicode)		ESC+K4	
HEX code	ESC <1B> ₁₆	K4 <4B> ₁₆ <34> ₁₆	Parameter an~n
Initial value	None		

Validity and valid duration of command	When the power switch is off	The set parameter is not maintained.
	Validity in a job	The set parameter becomes invalid.
	Validity after a job	The set parameter becomes invalid.

[Function]

Specifies W32 x H32 dots horizontally written Kanji.

[Format]

<K4>an~n

• Parameter

- | | | | |
|---|------------------------|---|--|
| a | [Kanji selection mode] | = | H : Hexadecimal character
B : Binary code
I : Smoothing function by hexadecimal character
C : Smoothing function by binary code
J : Highlighting function by hexadecimal character
D : Highlighting function by binary code
K : Smoothing and highlighting functions by hexadecimal character
E : Smoothing and highlighting functions by binary code |
| n | [Data] | = | Refer to Kanji code table (JIS, Shift JIS, Unicode) |

[Example 1] HEX characters of Shift JIS, Horizontal magnification: 3 times, Vertical magnification: 5 times

Data: (株) サトー

```
<A>
<V>100<H>200<P>2<L>0305
<K4>H81698A94816A83548367815B
<Q>2
<Z>
```

[Example 2] Binary code of JIS, Horizontal magnification: Twofold, Vertical magnification: 3 times

Data: (株) サトー

```
<A>
<V>100<H>200<P>2<L>0203
<K4>B!J3t!K%5%H!<
<Q>2
<Z>
```

[Note]

- | | | |
|----------------------------------|---|--|
| 1. HEX characters | = | Kanji Code 4 bytes ASCII / 1 Kanji character |
| 2. Binary code | = | Kanji Code 2 bytes / 1 Kanji character |
| 3. Smoothing functional range | = | Width and height : 3 to 12 times |
| 4. Highlighting functional range | = | Width and height : 1 to 5 times |

[Tip]

- In highlighting function, character width becomes wider based on the magnification ratio.
- Some characters may be unreadable when highlighting function is enabled.

[Valid commands]

Print position	<V>	<H>							
Modification	<P>	<L>	<%>	<&>	</>	<O>	<WD>		

8.15 Font

40 x 40 Dots Horizontal Flow Kanji (JIS / Shift JIS / Unicode)		ESC+K5	
HEX code	ESC <1B> ₁₆	K5 <4B> ₁₆ <35> ₁₆	Parameter an~n
Initial value	None		

Validity and valid duration of command	When the power switch is off	The set parameter is not maintained.
	Validity in a job	The set parameter becomes invalid.
	Validity after a job	The set parameter becomes invalid.

[Function]

Specifies W40 x H40 dots horizontally written Kanji.

[Format]

<K5>an~n

• Parameter

a	[Kanji selection mode]	=	H : Hexadecimal character B : Binary code I : Smoothing function by hexadecimal character C : Smoothing function by binary code J : Highlighting function by hexadecimal character D : Highlighting function by binary code K : Smoothing and highlighting functions by hexadecimal character E : Smoothing and highlighting functions by binary code
n	[Data]	=	Refer to Kanji code table (JIS, Shift JIS, Unicode)

[Example 1] HEX characters of Shift JIS, Horizontal magnification: 3 times, Vertical magnification: 5 times

Data: (株) サトー

```
<A>
<V>100<H>200<P>2<L>0305
<K5>H81698A94816A83548367815B
<Q>2
<Z>
```

[Example 2] Binary code of JIS, Horizontal magnification: Twofold, Vertical magnification: 3 times

Data: (株) サトー

```
<A>
<V>100<H>200<P>2<L>0203
<K5>B!J3t!K%5%H!<
<Q>2
<Z>
```

[Note]

- | | | |
|----------------------------------|---|--|
| 1. HEX characters | = | Kanji Code 4 bytes ASCII / 1 Kanji character |
| 2. Binary code | = | Kanji Code 2 bytes / 1 Kanji character |
| 3. Smoothing functional range | = | Width and height : 3 to 12 times |
| 4. Highlighting functional range | = | Width and height : 1 to 5 times |

[Tip]

- In highlighting function, character width becomes wider based on the magnification ratio.
- Some characters may be unreadable when highlighting function is enabled.

[Valid commands]

Print position	<V>	<H>							
Modification	<P>	<L>	<%>	<&>	</>	<O>	<WD>		

8.16 Font

16 x 16 Dots Horizontal Flow Kanji with 1-Byte Chr. (Shift JIS/Unicode)

ESC+K8

HEX code	ESC	K8	Parameter
	<1B> ₁₆	<4B> ₁₆ <38> ₁₆	an~n
Default setting	None		

Validity and valid duration of command	When the power switch is off	The set parameter is not maintained.
	Validity in a job	The set parameter becomes invalid.
	Validity after a job	The set parameter becomes invalid.

[Function]

Prints W16 x H16 dots horizontally written Kanji and W8 x H16 dots 1 byte characters.

[Format]

<K8>an~n

• Parameter

a	[Kanji selection mode]	=	H : Hexadecimal character B : Binary code I : Smoothing function by hexadecimal character C : Smoothing function by binary code J : Highlighting function by hexadecimal character D : Highlighting function by binary code K : Smoothing and highlighting functions by hexadecimal character E : Smoothing and highlighting functions by binary code
n	[Data]	=	Refer to Kanji code table (Shift JIS, Unicode)

[Example] HEX characters of Shift JIS, Data: 株式会社ト-

```
<A>
<V>100<H>200<P>2<L>0305
<K8>H8A948EAE89EF8ED0BBC42D
<Q>2
<Z>
```

[Note]

- | | | |
|----------------------------------|---|--|
| 1. HEX characters | = | Kanji Code 4 bytes ASCII / 1 Kanji character |
| 2. Binary code | = | Kanji Code 2 bytes ASCII / 1 Kanji character |
| 3. Smoothing functional range | = | Width and height : 3 to 12 times |
| 4. Highlighting functional range | = | Width and height : 1 to 5 times |

[Tip]

- In highlighting function, character width becomes wider based on the magnification ratio.
- Some characters may be unreadable when highlighting function is enabled.
- This command is available for Shift JIS Kanji and Unicode.
- For 1 byte character code, the font size is 8 x 16 dots.
- For 2-byte character code, the font size is 16 x 16 dots.

[Valid commands]

Print position	<V>	<H>							
Modification	<P>	<L>	<%>	<&>	</>	<0>	<WD>		

8.17 Font

24 x 24 Dots Horizontal Flow Kanji with 1-Byte Chr. (Shift JIS / Unicode)

ESC+K9

HEX code	ESC	K9	Parameter
	<1B> ₁₆	<4B> ₁₆ <39> ₁₆	an~n
Initial value	None		

Validity and valid duration of command	When the power switch is off	The set parameter is not maintained.
	Validity in a job	The set parameter becomes invalid.
	Validity after a job	The set parameter becomes invalid.

[Function]

Prints W24 x H24 dots horizontally written Kanji and W12 x H24 dots 1 byte characters.

[Format]

<K9>an~n

• Parameter

a	[Kanji selection mode]	=	H : Hexadecimal character B : Binary code I : Smoothing function by hexadecimal character C : Smoothing function by binary code J : Highlighting function by hexadecimal character D : Highlighting function by binary code K : Smoothing and highlighting functions by hexadecimal character E : Smoothing and highlighting functions by binary code
n	[Data]	=	Refer to Kanji code table (Shift JIS, Unicode)

[Example] HEX characters of Shift JIS, Data: 株式会社ト-

```
<A>
<V>100<H>200<P>2<L>0305
<K9>H8A948EAE89EF8ED0BBC42D
<Q>2
<Z>
```

[Note]

- | | | |
|----------------------------------|---|--|
| 1. HEX characters | = | Kanji Code 4 bytes ASCII / 1 Kanji character |
| 2. Binary code | = | Kanji Code 2 bytes ASCII / 1 Kanji character |
| 3. Smoothing functional range | = | Width and height : 3 to 12 times |
| 4. Highlighting functional range | = | Width and height : 1 to 5 times |

[Tip]

- In highlighting function, character width becomes wider based on the magnification ratio.
- Some characters may be unreadable when highlighting function is enabled.
- This command is available for Shift JIS Kanji code and Unicode.
- For 1 byte character code, the font size is 12 x 24 dots.
- For 2-byte character code, the font size is 24 x 24 dots.

[Valid commands]

Print position	<V>	<H>							
Modification	<P>	<L>	<%>	<&>	</>	<0>	<WD>		

8.18 Font			
22 x 22 Dots Horizontal Flow Kanji with 1-Byte Chr. (Shift JIS / Unicode)			ESC+KA
HEX code	ESC <1B> ₁₆	KA <4B> ₁₆ <41> ₁₆	Parameter an~n
Initial value	None		
Validity and valid duration of command	When the power switch is off	The set parameter is not maintained.	
	Validity in a job	The set parameter becomes invalid.	
	Validity after a job	The set parameter becomes invalid.	

[Function]

Prints W22 x H22 dots horizontally written Kanji and W11 x H22 dots 1 byte characters.

[Format]

<KA>an~n

• Parameter

- a [Kanji selection mode] = H: Hexadecimal character
 B: Binary code
 I: Smoothing function by Hexadecimal character
 C: Smoothing function by Binary code
 J: Highlighting function by Hexadecimal character
 D: Highlighting function by Binary code
 K: Smoothing and highlighting functions by Hexadecimal character
 E: Smoothing and highlighting functions by Binary code
- n [Data] = See the Kanji code table (Shift JIS, Unicode).

[Example 1] HEX characters of Shift JIS, Data: 株式会社

```
<A>
<V>100<H>200<P>2<L>0305
<KA>H8A948EAE89EF8ED0BBCC42D
<Q>2
<Z>
```

[Note]

- Hexadecimal character = Kanji code 4 bytes ASCII / 1 Kanji character
- Binary code = Kanji code 2 bytes ASCII / 1 Kanji character
- Smoothing functional range = Width and height : 3 to 12 times
- Highlighting functional range = Width and height : 1 to 5 times

[Tip]

- In highlighting function, character width becomes wider based on the magnification ratio.
- Some characters may be unreadable when highlighting function is enabled.
- This command is available for Shift JIS Kanji code and Unicode.
- For 1 byte character code, the font size is 11 x 22 dots.
- For 2-byte character code, the font size is 22 x 22 dots.
- 1 byte character is printed in Mincho style.

[Valid Commands]

Print position	<V>	<H>								
Modification	<P>	<L>	<%>	<&>	</>	<O>	<WD>			

8.19 Font			
32 x 32 Dots Horizontal Flow Kanji with 1 -Byte Chr. (Shift JIS/Unicode)			ESC+KB
HEX code	ESC <1B> ₁₆	KB <4B> ₁₆ <42> ₁₆	Parameter an~n
Initial value	None		
Validity and valid duration of command	When the power switch is off	The set parameter is not maintained.	
	Validity in a job	The set parameter becomes invalid.	
	Validity after a job	The set parameter becomes invalid.	

[Function]

Prints W32 x H32 dots horizontally written Kanji and W16 x 32 dots 1 byte characters.

[Format]

<KB>an~n

• Parameter

- a [Kanji selection mode] = H: Hexadecimal character
 B: Binary code
 I: Smoothing function by Hexadecimal character
 C: Smoothing function by Binary code
 J: Highlighting function by Hexadecimal character
 D: Highlighting function by Binary code
 K: Smoothing and highlighting functions by Hexadecimal character
 E: Smoothing and highlighting functions by Binary code
- n [Data] = See the Kanji code table (Shift JIS, Unicode).

[Example 1] HEX characters of Shift JIS, Data: 株式会社 株式会社

```
<A>
<V>100<H>200<P>2<L>0305
<KB>H8A948EAE89EF8ED0BBCC42D
<Q>2
<Z>
```

[Note]

- Hexadecimal character = Kanji code 4 bytes ASCII / 1 Kanji character
- Binary code = Kanji code 2 bytes ASCII / 1 Kanji character
- Smoothing functional range = Width and height : 3 to 12 times
- Highlighting functional range = Width and height: 1 to 5 times

[Tip]

- In highlighting function, character width becomes wider based on the magnification ratio.
- Some characters may be unreadable when highlighting function is enabled.
- This command is available for Shift JIS Kanji code and Unicode.
- For 1 byte character code, the font size is 16 x 32 dots.
- For 2-byte character code, the font size is 32 x 32 dots.
- 1 byte character is printed in Mincho style.

[Valid Commands]

Print position	<V>	<H>								
Modification	<P>	<L>	<%>	<&>	</>	<O>	<WD>			

8.20 Font			
40 x 40 Dots Horizontal Flow Kanji with 1-Byte Chr. (Shift JIS / Unicode)			ESC+KD
HEX code	ESC <1B> ₁₆	KD <4B> ₁₆ <44> ₁₆	Parameter an~n
Initial value	None		
Validity and valid duration of command	When the power switch is off	The set parameter is not maintained.	
	Validity in a job	The set parameter becomes invalid.	
	Validity after a job	The set parameter becomes invalid.	

[Function]

Prints W40 x H40 dots horizontally written Kanji and W20 x H40 dots 1 byte characters.

[Format]

<kD>an~n

• Parameter

- a [Kanji selection mode] = H: Hexadecimal character
 B: Binary code
 I: Smoothing function by Hexadecimal character
 C: Smoothing function by Binary code
 J: Highlighting function by Hexadecimal character
 D: Highlighting function by Binary code
 K: Smoothing and highlighting functions by Hexadecimal character
 E: Smoothing and highlighting functions by Binary code
- n [Data] = See the Kanji code table (Shift JIS, Unicode).

[Example 1] HEX characters of Shift JIS, Horizontal magnification: 3 times, Vertical magnification: 5 times

Data: (株) サトー
 <A>
 <V>100<H>200<P>2<L>0305
<KD>H8A948EAE89EF8ED0BBC42D
 <Q>2
 <Z>

[Note]

- Hexadecimal character = Kanji code 4 bytes ASCII / 1 Kanji character
- Binary code = Kanji code 2 bytes ASCII / 1 Kanji character
- Smoothing functional range = Width and height : 3 to 12 times
- Highlighting functional range = Width and height: 1 to 5 times

[Tip]

- In highlighting function, character width becomes wider based on the magnification ratio.
- Some characters may be unreadable when highlighting function is enabled.
- This command is available for Shift JIS Kanji code and Unicode.
- For 1 byte character code, the font size is 20 x 40 dots.
- For 2-byte character code, the font size is 40 x 40 dots.
- 1 byte character is printed in Mincho style.

[Valid Commands]

Print position	<V>	<H>							
Modification	<P>	<L>	<%>	<&>	</>	<O>	<WD>		

8.21 Font

16x16 Dots Vertical Flow Kanji (JIS / Shift JIS / Unicode)	ESC+k1
---	---------------

HEX code	ESC	k1	Parameter
	<1B> ₁₆	<6B> ₁₆ <31> ₁₆	an~n
Initial value	None		

Validity and valid duration of command	When the power switch is off	The set parameter is not maintained.
	Validity in a job	The set parameter becomes invalid.
	Validity after a job	The set parameter becomes invalid.

[Function]

Specifies W16 x H16 dots vertically oriented Kanji.

[Format]

<k1>an~n

• Parameter

- a [Kanji selection mode] = H: Hexadecimal character
 B: Binary code
 I: Smoothing function by Hexadecimal character
 C: Smoothing function by Binary code
 J: Highlighting function by Hexadecimal character
 D: Highlighting function by Binary code
 K: Smoothing and highlighting functions by Hexadecimal character
 E: Smoothing and highlighting functions by Binary code
- n [Data] = See the Kanji code table (JIS, Shift JIS, Unicode).

[Example 1] HEX characters of Shift JIS, Horizontal magnification: 3 times, Vertical magnification: 5 times

Data: (株) サトー
 <A>
 <V>100<H>200<P>2<L>0305
<k1>H81698A94816A83548367815B
 <Q>2
 <Z>

[Example 2] Binary code of JIS, Horizontal magnification: Twofold, Vertical magnification: 3 times

Data: (株) サトー
 <A>
 <V>100<H>200<P>2<L>0203
<k1>BIJ3t!K%5%HI<
 <Q>2
 <Z>

[Note]

1. HEX characters = Kanji Code 4 bytes ASCII / 1 Kanji character
2. Binary code = Kanji Code 2 bytes / 1 Kanji character
3. Smoothing functional range = Width and height : 3 to 12 times
4. Highlighting functional range = Width and height : 1 to 5 times

[Tip]

1. In highlighting function, character width becomes wider based on the magnification ratio.
2. Some characters may be unreadable when highlighting function is enabled.

[Valid commands]

Print position	<V>	<H>							
Modification	<P>	<L>	<%>	<&>	</>	<0>	<WD>		

8.22 Font

24 x 24 Dots Vertical Flow Kanji (JIS / Shift JIS / Unicode)	ESC+k2
---	---------------

HEX code	ESC	k2	Parameter
	<1B> ₁₆	<6B> ₁₆ <32> ₁₆	an~n
Initial value	None		

Validity and valid duration of command	When the power switch is off	The set parameter is not maintained.
	Validity in a job	The set parameter becomes invalid.
	Validity after a job	The set parameter becomes invalid.

[Function]

Specifies W24 x H24 dots vertically oriented Kanji.

[Format]

<k2>an~n

• Parameter

- a [Kanji selection mode] = H: Hexadecimal character
 B: Binary code
 I: Smoothing function by Hexadecimal character
 C: Smoothing function by Binary code
 J: Highlighting function by Hexadecimal character
 D: Highlighting function by Binary code
 K: Smoothing and highlighting functions by Hexadecimal character
 E: Smoothing and highlighting functions by Binary code
- n [Data] = See the Kanji code table (JIS, Shift JIS, Unicode).

[Example 1] HEX characters of Shift JIS, Horizontal magnification: 3 times, Vertical magnification: 5 times

Data: (株) サトー
 <A>
 <V>100<H>200<P>2<L>0305
<k2>H81698A94816A83548367815B
 <Q>2
 <Z>

[Example 2] Binary code of JIS, Horizontal magnification: Twofold, Vertical magnification: 3 times

Data: (株) サトー
 <A>
 <V>100<H>200<P>2<L>0203
<k2>BIJ3t!K%5%HI<
 <Q>2
 <Z>

[Note]

1. HEX characters = Kanji Code 4 bytes ASCII / 1 Kanji character
2. Binary code = Kanji Code 2 bytes / 1 Kanji character
3. Smoothing functional range = Width and height : 3 to 12 times
4. Highlighting functional range = Width and height : 1 to 5 times

[Tip]

1. In highlighting function, character width becomes wider based on the magnification ratio.
2. Some characters may be unreadable when highlighting function is enabled.

[Valid commands]

Print position	<V>	<H>							
Modification	<P>	<L>	<%>	<&>	</>	<0>	<WD>		

8.23 Font

22 x 22 Dots Vertical Flow Kanji (JIS / Shift JIS / Unicode)

ESC+k3

HEX code	ESC	k3	Parameter
	<1B> ₁₆	<6B> ₁₆ <33> ₁₆	an~n
Initial value	None		

Validity and valid duration of command	When the power switch is off	The set parameter is not maintained.
	Validity in a job	The set parameter becomes invalid.
	Validity after a job	The set parameter becomes invalid.

[Function]

Specifies W22 x H22 dots vertically oriented Kanji.

[Format]

<k3>an~n

• Parameter

a [Kanji selection mode] = H: Hexadecimal character
 B: Binary code
 I: Smoothing function by Hexadecimal character
 C: Smoothing function by Binary code
 J: Highlighting function by Hexadecimal character
 D: Highlighting function by Binary code
 K: Smoothing and highlighting functions by Hexadecimal character
 E: Smoothing and highlighting functions by Binary code

n [Data] = See the Kanji code table (JIS, Shift JIS, Unicode).

[Example 1] HEX characters of Shift JIS, Horizontal magnification: 3 times, Vertical magnification: 5 times

Data: (株) サトー
 <A>
 <V>100<H>200<P>2<L>0305
<k3>H81698A94816A83548367815B
 <Q>2
 <Z>

[Example 2] Binary code of JIS, Horizontal magnification: Twofold, Vertical magnification: 3 times

Data: (株) サトー
 <A>
 <V>100<H>200<P>2<L>0203
<k3>BIJ3t!K%5%H!<
 <Q>2
 <Z>

[Note]

1. HEX characters = Kanji Code 4 bytes ASCII / 1 Kanji character
2. Binary code = Kanji Code 2 bytes / 1 Kanji character
3. Smoothing functional range = Width and height : 3 to 12 times
4. Highlighting functional range = Width and height : 1 to 5 times

[Tip]

1. In highlighting function, character width becomes wider based on the magnification ratio.
2. Some characters may be unreadable when highlighting function is enabled.

[Valid commands]

Print position	<V>	<H>							
Modification	<P>	<L>	<%>	<&>	</>	<0>	<WD>		

8.24 Font

32 x 32 Dots Vertical Flow Kanji (JIS / Shift JIS / Unicode)

ESC+k4

HEX code	ESC <1B> ₁₆	k4 <6B> ₁₆ <34> ₁₆	Parameter an~n
Initial value	None		

Validity and valid duration of command	When the power switch is off	The set parameter is not maintained.
	Validity in a job	The set parameter becomes invalid.
	Validity after a job	The set parameter becomes invalid.

[Function]

Specifies W32 x H32 dots vertically oriented Kanji.

[Format]

<k4>an~n

• Parameter

- a [Kanji selection mode] = H: Hexadecimal character
 B: Binary code
 I: Smoothing function by Hexadecimal character
 C: Smoothing function by Binary code
 J: Highlighting function by Hexadecimal character
 D: Highlighting function by Binary code
 K: Smoothing and highlighting functions by Hexadecimal character
 E: Smoothing and highlighting functions by Binary code
- n [Data] = See the Kanji code table (JIS, Shift JIS, Unicode).

[Example 1] HEX characters of Shift JIS, Horizontal magnification: 3 times, Vertical magnification: 5 times

Data: (株) サトー
 <A>
 <V>100<H>200<P>2<L>0305
<k4>H81698A94816A83548367815B
 <Q>2
 <Z>

[Example 2] Binary code of JIS, Horizontal magnification: Twofold, Vertical magnification: 3 times

Data: (株) サトー
 <A>
 <V>100<H>200<P>2<L>0203
<k4>B!J3t!K%5%H!<
 <Q>2
 <Z>

[Note]

- Hexadecimal character = Kanji code 4 bytes ASCII / 1 Kanji character
- Binary code = Kanji code 2 bytes / 1 Kanji character
- Smoothing functional range = Width and height : 3 to 12 times
- Highlighting functional range = Width and height : 1 to 5 times

[Tip]

- In highlighting function, character width becomes wider based on the magnification ratio.
- Some characters may be unreadable when highlighting function is enabled.

[Valid commands]

Print position	<V>	<H>	<P>	<L>	<Q>	<Z>	<WD>			
Modification	<P>	<L>	<%>	<&>	</>	<O>	<WD>			

8.25 Font

40 x 40 Dots Vertical Flow Kanji (JIS / Shift JIS / Unicode)

ESC+k5

HEX code	ESC <1B> ₁₆	k5 <6B> ₁₆ <35> ₁₆	Parameter an~n
Initial value	None		

Validity and valid duration of command	When the power switch is off	The set parameter is not maintained.
	Validity in a job	The set parameter becomes invalid.
	Validity after a job	The set parameter becomes invalid.

[Function]

Specifies W40 x H40 dots vertically oriented Kanji.

[Format]

<k5>an~n

• Parameter

a [Kanji selection mode] = H: Hexadecimal character
 B: Binary code
 I: Smoothing function by Hexadecimal character
 C: Smoothing function by Binary code
 J: Highlighting function by Hexadecimal character
 D: Highlighting function by Binary code
 K: Smoothing and highlighting functions by Hexadecimal character
 E: Smoothing and highlighting functions by Binary code

n [Data] = See the Kanji code table (JIS, Shift JIS, Unicode).

[Example 1] Hexadecimal characters of Shift JIS, Horizontal magnification: 3 times, Vertical magnification: 5 times

Data: (株) サトー

```
<A>
<V>100<H>200<P>2<L>0305
<k5>H81698A94816A83548367815B
<Q>2
<Z>
```

[Example 2] Binary code of JIS, Horizontal magnification: Twofold, Vertical magnification: 3 times

Data: (株) サトー

```
<A>
<V>100<H>200<P>2<L>0203
<k5>B!J3t!K%5%H!<
<Q>2
<Z>
```

[Note]

- Hexadecimal character = Kanji code 4 bytes ASCII / 1 Kanji character
- Binary code = Kanji code 2 bytes / 1 Kanji character
- Smoothing functional range = Width and height : 3 to 12 times
- Highlighting functional range = Width and height : 1 to 5 times

[Tip]

- In highlighting function, character width becomes wider based on the magnification ratio.
- Some characters may be unreadable when highlighting function is enabled.

[Valid Commands]

Print position	<V>	<H>	<P>	<L>	<Q>	<Z>	<WD>			
Modification	<P>	<L>	<%>	<&>	</>	<O>	<WD>			

8.26 Font

16x16 Dots Vertical Flow Kanji with 1-Byte Chr. (Shift JIS/Unicode)	ESC+k8
--	---------------

HEX code	ESC	k8	Parameter
	<1B> ₁₆	<6B> ₁₆ <38> ₁₆	an~n
Initial value	None		

Validity and valid duration of command	When the power switch is off	The set parameter is not maintained.
	Validity in a job	The set parameter becomes invalid.
	Validity after a job	The set parameter becomes invalid.

[Function]

Prints W16 x H16 dots vertically oriented Kanji and W8 x H16 dot 1 byte characters.

[Format]

<k8>an~n

• Parameter

- | | | | |
|---|------------------------|---|--|
| a | [Kanji selection mode] | | = H: Hexadecimal character
B: Binary code
I: Smoothing function by Hexadecimal character
C: Smoothing function by Binary code
J: Highlighting function by Hexadecimal character
D: Highlighting function by Binary code
K: Smoothing and highlighting functions by Hexadecimal character
E: Smoothing and highlighting functions by Binary code |
| n | [Data] | = | See the Kanji code table (Shift JIS, Unicode). |

[Example]

HEX characters of Shift JIS, Horizontal magnification: 3 times, Vertical magnification: 5 times
 Data: 株式会社

```
<A>
<V>100<H>200<P>2<L>0305
<k8>H8A948EAE89EF8ED0BBC42D
<Q>2
<Z>
```

[Note]

- | | | |
|----------------------------------|--|--|
| 1. HEX characters | | = Kanji Code 4 bytes ASCII / 1 Kanji character |
| 2. Binary code | | = Kanji Code 2 bytes ASCII / 1 Kanji character |
| 3. Smoothing functional range | | = Width and height : 3 to 12 times |
| 4. Highlighting functional range | | = Width and height : 1 to 5 times |

[Tip]

1. In highlighting function, character width becomes wider based on the magnification ratio.
2. Some characters may be unreadable when highlighting function is enabled.
3. This command is available for Shift JIS Kanji code and Unicode.
4. For 1 byte character code, the font size is 8 x 16 dots.
5. For 2-byte character code, the font size is 16 x 16 dots.
6. 1 byte character is printed in Mincho style.

[Important]

1. When 1 byte character with voiced sound mark and semi-voiced sound mark is specified, the character, the voiced sound mark and the semi-voiced sound mark will appear individually.

Example) When [^ -] is specified, it will appears as [^] [^] [-].



[Valid commands]

Print position	<V>	<H>							
Modification	<P>	<L>	<%>	<&>	</>	<0>	<WD>		

8.27 Font

24 x 24 Dots Vertical Flow Kanji with 1-Byte Chr. (Shift JIS/Unicode)	ESC+k9
--	---------------

HEX code	ESC	k9	Parameter
	<1B> ₁₆	<6B> ₁₆ <39> ₁₆	an~n
Initial value	None		

Validity and valid duration of command	When the power switch is off	The set parameter is not maintained.
	Validity in a job	The set parameter becomes invalid.
	Validity after a job	The set parameter becomes invalid.

[Function]

Prints W24 x H24 dots vertically oriented Kanji and W12 x H24 dots 1 byte characters.

[Format]

<k9>an~n

• Parameter

- a [Kanji selection mode] = H: Hexadecimal character
 B: Binary code
 I: Smoothing function by Hexadecimal character
 C: Smoothing function by Binary code
 J: Highlighting function by Hexadecimal character
 D: Highlighting function by Binary code
 K: Smoothing and highlighting functions by Hexadecimal character
 E: Smoothing and highlighting functions by Binary code
- n [Data] = See the Kanji code table (Shift JIS, Unicode).

[Example] HEX characters of Shift JIS, Horizontal magnification: 3 times, Vertical magnification: 5 times

Data: 株式会社
 <A>
 <V>100<H>200<P>2<L>0305
<k9>H8A948EAE89EF8ED0BBC42D
 <Q>2
 <Z>

[Note]

1. HEX characters = Kanji Code 4 bytes ASCII / 1 Kanji character
2. Binary code = Kanji Code 2 bytes ASCII / 1 Kanji character
3. Smoothing functional range = Width and height : 3 to 12 times
4. Highlighting functional range = Width and height : 1 to 5 times

[Tip]

1. In highlighting function, character width becomes wider based on the magnification ratio.
2. Some characters may be unreadable when highlighting function is enabled.
3. This command is available for Shift JIS Kanji code and Unicode.
4. For 1 byte character code, the font size is 12 x 24 dots.
5. For 2-byte character code, the font size is 24 x 24 dots.
6. 1 byte character is printed in Mincho style.

[Important]

1. When 1 byte character with voiced sound mark and semi-voiced sound mark is specified, the character, the voiced sound mark and the semi-voiced sound mark will appear individually.

Example) When [^ -] is specified, it will appears as [^] [^] [-].



[Valid commands]

Print position	<V>	<H>							
Modification	<P>	<L>	<%>	<&>	</>	<0>	<WD>		

8.28 Font

22 x 22 Dots Vertical Flow Kanji with 1-Byte Chr. (Shift JIS/Unicode)

ESC+kA

HEX code	ESC <1B> ₁₆	kA <6B> ₁₆ <41> ₁₆	Parameter an~n
Initial value	None		

Validity and valid duration of command	When the power switch is off	The set parameter is not maintained.
	Validity in a job	The set parameter becomes invalid.
	Validity after a job	The set parameter becomes invalid.

[Function]

Prints W22 x H22 dots vertically oriented Kanji and W11 x H22 dots 1 byte characters.

[Format]

<kA>an~n

• Parameter

- a [Kanji selection mode] = H: Hexadecimal character
 B: Binary code
 I: Smoothing function by Hexadecimal character
 C: Smoothing function by Binary code
 J: Highlighting function by Hexadecimal character
 D: Highlighting function by Binary code
 K: Smoothing and highlighting functions by Hexadecimal character
 E: Smoothing and highlighting functions by Binary code
- n [Data] = See the Kanji code table (Shift JIS, Unicode).

[Example] HEX characters of Shift JIS, Horizontal magnification: 3 times, Vertical magnification: 5 times

Data: 株式会社

```
<A>
<V>100<H>200<P>2<L>0305
<kA>H8A948EAE89EF8ED0BBC42D
<Q>2
<Z>
```

[Note]

1. HEX characters = Kanji code 4 bytes ASCII / 1 Kanji character
2. Binary code = Kanji code 2 bytes ASCII / 1 Kanji character
3. Smoothing range = Width and height : 3 to 12 times
4. Highlighting range = Width and height: 1 to 5 times

[Tip]

1. In highlighting function, character width becomes wider based on the magnification ratio.
2. Some characters may be unreadable when highlighting function is enabled.
3. This command is available for Shift JIS Kanji code and Unicode.
4. For 1 byte character code, the font size is 11 x 22 dots.
5. For 2-byte character code, the font size is 22 x 22 dots.
6. 1 byte character is printed in Mincho style.

[Important]

1. When 1 byte character with voiced sound mark and semi-voiced sound mark is specified, the character, the voiced sound mark and the semi-voiced sound mark will appear individually.

Example) When [^ -] is specified, it will appears as [^] [^] [-].

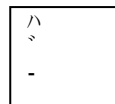

[Valid Commands]

Print position	<V>	<H>								
Modification	<P>	<L>	<%>	<&>	</>	<O>	<WD>			

8.29 Font

32 x 32 Dots Vertical Flow Kanji with 1-Byte Chr. (Shift JIS/Unicode)

ESC+kB

HEX code	ESC <1B> ₁₆	kB <6B> ₁₆ <42> ₁₆	Parameter an~n
Initial value	None		

Validity and valid duration of command	When the power switch is off	The set parameter is not maintained.
	Validity in a job	The set parameter becomes invalid.
	Validity after a job	The set parameter becomes invalid.

[Function]

Prints W32 x H32 dots vertically oriented Kanji and W16 x H32 dots 1 byte characters.

[Format]

<kB>an~n

• Parameter

- a [Kanji selection mode] = H: Hexadecimal character
 B: Binary code
 I: Smoothing function by Hexadecimal character
 C: Smoothing function by Binary code
 J: Highlighting function by Hexadecimal character
 D: Highlighting function by Binary code
 K: Smoothing and highlighting functions by Hexadecimal character
 E: Smoothing and highlighting functions by Binary code
- n [Data] = See the Kanji code table (Shift JIS, Unicode).

[Example] HEX characters of Shift JIS, Horizontal magnification: 3 times, Vertical magnification: 5 times

Data: 株式会社

```
<A>
<V>100<H>200<P>2<L>0305
<kB>H8A948EAE89EF8ED0BBC42D
<Q>2
<Z>
```

- | | |
|--------------------------|--|
| 1. Hexadecimal character | = Kanji code 4 bytes ASCII / 1 Kanji character |
| 2. Binary code | = Kanji code 2 bytes ASCII / 1 Kanji character |
| 3. Smoothing range | = Width and height : 3 to 12 times |
| 4. Highlighting range | = Width and height : 1 to 5 times |

[Tip]

- In highlighting function, character width becomes wider based on the magnification ratio.
- Some characters may be unreadable when highlighting function is enabled.
- This command is available for Shift JIS Kanji code and Unicode.
- For 1 byte character code, the font size is 16 x 32 dots.
- For 2-byte character code, the font size is 32 x 32 dots.
- 1 byte character is printed in Mincho style.

[Valid commands]

Print position	<V>	<H>							
Modification	<P>	<L>	<%>	<&>	</>	<O>	<WD>		

8.30 Font			
40 x 40 Dots Vertical Flow Kanji with 1-Byte Chr. (Shift JIS/Unicode)			ESC+kD
HEX code	ESC <1B> ₁₆	kD <6B> ₁₆ <44> ₁₆	Parameter an~n
Initial value	None		
Validity and valid duration of command	When the power switch is off	The set parameter is not maintained.	
	Validity in a job	The set parameter becomes invalid.	
	Validity after a job	The set parameter becomes invalid.	

[Function]

Prints W40 x H40 dots vertically oriented Kanji and W20 x H40 dots 1 byte characters.

[Format]

<kD>an~n

• Parameter

- a [Kanji selection mode] = H: Hexadecimal character
 B: Binary code
 I: Smoothing function by Hexadecimal character
 C: Smoothing function by Binary code
 J: Highlighting function by Hexadecimal character
 D: Highlighting function by Binary code
 K: Smoothing and highlighting functions by Hexadecimal character
 E: Smoothing and highlighting functions by Binary code
- n [Data] = See the Kanji code table (Shift JIS, Unicode).

[Example] HEX characters of Shift JIS, Horizontal magnification: 3 times, Vertical magnification: 5 times

Data: 株式会社
 <A>
 <V>100<H>200<P>2<L>0305
 <kD>H8A948EAE89EF8ED0BBC42D
 <Q>2
 <Z>

- | | |
|--------------------------|--|
| 1. Hexadecimal character | = Kanji code 4 bytes ASCII / 1 Kanji character |
| 2. Binary code | = Kanji code 2 bytes ASCII / 1 Kanji character |
| 3. Smoothing range | = Width and height : 3 to 12 times |
| 4. Highlighting range | = Width and height : 1 to 5 times |

[Tip]

- In highlighting function, character width becomes wider based on the magnification ratio.
- Some characters may be unreadable when highlighting function is enabled.
- This command is available for Shift JIS Kanji code and Unicode.
- For 1 byte character code, the font size is 20 x 40 dots.
- For 2-byte character code, the font size is 40 x 40 dots.
- 1 byte character will be printed in Mincho style.

[Valid commands]

Print position	<V>	<H>							
Modification	<P>	<L>	<%>	<&>	</>	<O>	<WD>		

8.31 Font

<h1>Store 16x16 Dots External Character</h1>	<h1>ESC+T1</h1>
--	-----------------

HEX code	ESC	T1	Parameter
	<1B> ₁₆	<54> ₁₆ <31> ₁₆	abbn~n
Initial value	None		

Validity and valid duration of command	When the power switch is off	The set parameter is not maintained.
	Validity in a job	The set parameter becomes invalid.
	Validity after a job	The set parameter becomes invalid.

[Function]

Stores external character in W16 x H16 dots

[Format]

<T1>abbn~n

• Parameter

- a [Selection of registered data type] = H: Registered data in hexadecimal character
= B: Registered data in binary code
- b [Registered font code address] <JIS code specification>
H: Within the range from 21 to 7F, up to 95 entries..
B: Within the range from 21H to 7FH, up to 95 entries..
<Shift JIS specification>
H: Within the range from 40 to 9E, up to 95 entries..
B: Within the range from 40H to 9EH, up to 95 entries..
<Unicode specification>
H: Within the range from 00 to 5E, up to 95 entries..
B: Within the range from 00H to 5EH, up to 95 entries.
- n [External character registered data] = Data

[Example 1] Registered data in hexadecimal character of JIS

```
<A>
<T1>H21
00FF-----FF00
<Z>

<A>
<V>100<H>200<K1>H9021
<Q>2
<Z>
```

[Example 2] Registered data in binary code of Shift JIS

```
<A>
<T1>B<40>16
<00FF-----FF00>16
<Z>

<A>
<V>100<H>200<K1>B<90>16<40>16
<Q>2
<Z>
```

[Example 3] Registered data in binary code of Unicode

```
<A>
<T1>B<00>16
<00FF . . . . . FF00>16
<Z>

<A>
<V>100<H>200<K1>B<E0>16<00>16
<Q>2
<Z>
```

[Example 4] When registering data to user registration memory

```
<A>
<CC>1
<T1>B<40>16
<00FF . . . . . FF00>16
<Z>
```

[Note]

1. Registers W16 x H16 dots external character to internal memory.
2. Concerning the font code address to be registered, specify a font according to the [Kanji code mode] of the printer- JIS code, Shift JIS code or Unicode. When the Ryobi font is used, only Unicode is available.
3. Re-entry to the registered area is allowed.
4. Refer to the data registration procedure below.
5. Registered data in the printer memory will be cleared by turning off the printer. Register the data again.
6. When the Kanji data is replaced (NEC \leftrightarrow Ryobi font), register the data again after deleting external characters.

External character file [16×16]

D1	D2
D3	D4
D5	D6
.	.
.	.
.	.
D31	D32

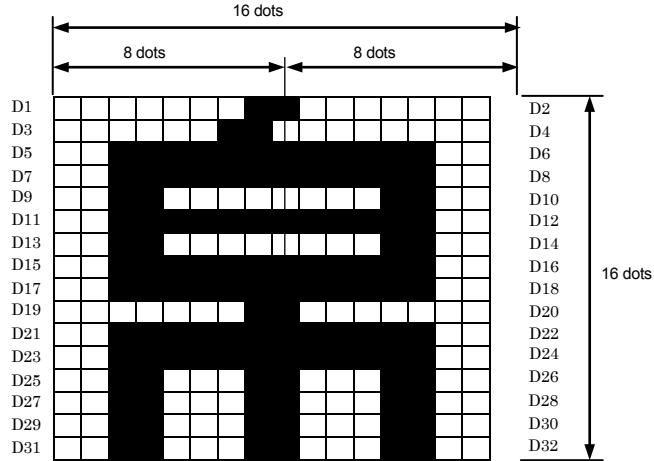

D1 and D2 respectively consists of [00000001] and [10000000]. To register the above external character, consider D1 data as $\langle 01 \rangle_{16}$ and D2 data as $\langle 80 \rangle_{16}$.

In the same manner, D3 as $\langle 03 \rangle_{16}$, D4 as $\langle 00 \rangle_{16}$, D5 as $\langle 3F \rangle_{16}$, and D6 as $\langle FC \rangle_{16}$, so that the specification of external character registered data will be $\langle 018003003FFC \dots \rangle_{16}$ and up to D32.

[Tip]

1. Registered data in the user registration memory cannot be cleared by turning off the printer.
2. Internal memory and user registration memory cannot be specified at the same time.

8.32 Font

<h1>Store 24x24 Dots External Character</h1>	<h1>ESC+T2</h1>
--	-----------------

HEX code	ESC <1B> ₁₆	T2 <54> ₁₆ <32> ₁₆	Parameter abbn~n
Initial value	None		

Validity and valid duration of command	When the power switch is off	The set parameter is not maintained.
	Validity in a job	The set parameter becomes invalid.
	Validity after a job	The set parameter becomes invalid.

[Function]

Stores external character in W24 x H24 dots

[Format]

<T2>abbn~n

• Parameter

- a [Selection of registered data type] = H: Registered data in hexadecimal character
= B: Registered data in binary code
- b [Registered font code address] <JIS code specification>
H: Within the range from 21 to 7F, up to 95 entries.
B: Within the range from 21H to 7FH, up to 95 entries.
<Shift JIS specification>
H: Within the range from 40 to 9E, up to 95 entries.
B: Within the range from 40H to 9EH, up to 95 entries.
<Unicode specification>
H: Within the range from 00 to 5E, up to 95 entries.
B: Within the range from 00H to 5EH, up to 95 entries.
- n [External character registered data] = Data

[Example 1] Registered data in hexadecimal character of JIS code

```
<A>
<T2>H21
00FF.....FF00
<Z>

<A>
<V>100 <H>200 <K2>H9021
<Q>2
<Z>
```

[Example 2] Registered data in binary code of Shift JIS

```
<A>
<T2>B<40>16
<00FF.....FF00>16
<Z>

<A>
<V>100<H>200<K2>B<90>16<40>16
<Q>2
<Z>
```

[Example 3] Registered data in binary code of Unicode

```
<A>
<T2>B<00>16
<00FF.....FF00>16
<Z>

<A>
<V>100<H>200<K2>B<E0>16<00>16
<Q>2
<Z>
```

[Example 4] When registering data to user registration memory

```
<A>
<CC>1
<T2>B<41>16
<00FF.....FF00>16
<Z>
```

[Note]

1. Registers W24 x H24 dots external character to internal memory.
2. Concerning the font code address to be registered, specify a font according to the [Kanji code mode] of the printer- JIS code, Shift JIS code or Unicode. When the Ryobi font is used, only Unicode is available.
3. Re-entry to the registered area is allowed.
4. Refer to the data registration procedure below.
5. Registered data in the printer memory will be cleared by turning off the printer. Register the data again.
6. When the Kanji data is replaced (NEC ↔ Ryobi font), register the data again after deleting external characters.

External character file [24×24]

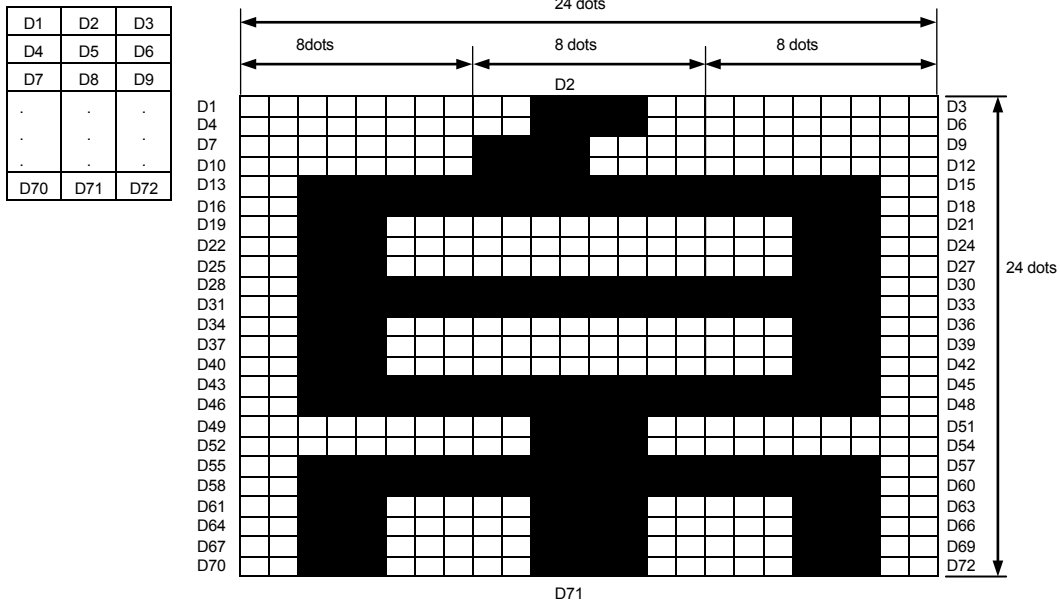

D1, D2 and D3 respectively consist of [00000000], [00111100] and [00000000]; therefore, to register the above external character, consider D1 data as <00>₁₆, D2 data as <3C>₁₆ and D3 data as <00>₁₆. In the same manner, D4 as <00>₁₆, D5 as <3C>₁₆, D6 as <00>₁₆, so that the specification of external character registered data will be <003C00003C00...>₁₆ and up to D72.

[Tip]

1. Registered data in the user registration memory cannot be cleared by turning off the printer.
2. Internal memory and user registration memory cannot be specified at the same time.

8.33 Font

<h1 style="margin: 0;">Recall Horizontal Flow External Character</h1>	<h1 style="margin: 0;">ESC+K1 (K2)</h1>
---	---

HEX code	ESC	K1 (K2)	Parameter
	<1B> ₁₆	<4B> ₁₆ <31> ₁₆ (<4B> ₁₆ <32> ₁₆)	ab~b
Initial value	None		

Validity and valid duration of command	When the power switch is off	The set parameter is not maintained.
	Validity in a job	The set parameter becomes invalid.
	Validity after a job	The set parameter becomes invalid.

[Function]

Recalls and prints the horizontally written external character registered in the printer memory.

[Format]

<K1>ab~b

<K2>ab~b

• Parameter

- a [External character specification mode] = H: Hexadecimal character
 B: Binary code
 I: Smoothing function by Hexadecimal character
 C: Smoothing function by Binary code
 J: Highlighting function by Hexadecimal character
 D: Highlighting function by Binary code
 K: Smoothing and highlighting functions by Hexadecimal character
 E: Smoothing and highlighting functions by Binary code

- b [Registration code] <JIS code>
 H,I,J,K : "9021" ~ "907F"
 B,C,D,E : 9021H ~ 907FH
 <Shift JIS code>
 H,I,J,K : "F040" ~ "F09E"
 B,C,D,E : F040H ~ F09EH
 <Unicode>
 H,I,J,K : "E000" ~ "E05E"
 B,C,D,E : E000H ~ E05EH

[Example 1] Recalls 16 x 16 external character, Registered data in hexadecimal character of JIS

```
<A>
<T1>H21
00FF..... FF00
<Z>

<A>
<V>100<H>200<K1>H9021
<Q>2
<Z>
```

[Example 2] Recalls 24 x 24 external character, Registered data in binary code of Shift JIS

```
<A>
<T2>B<40>16
<00FF..... FF00>16
<Z>

<A>
<V>100<H>200<K2>B<F0>16<40>16
<Q>2
<Z>
```

[Example 3] Recalls 16 x 16 external character, Registered data in hexadecimal character of Unicode

```
<A>
<T1>H01
00FF..... FF00
<Z>

<A>
<V>100<H>200<K1>HE001
<Q>2
<Z>
```

[Note]

1. If a print error occurs, register again.
2. The external characters registered by JIS or Shift JIS cannot be recalled by Unicode. Also the external characters registered by Unicode cannot be recalled by JIS or Shift JIS.

8.34 Font

Recall Vertical Flow		ESC+k1 (k2)	
HEX code	ESC	k1 (k2)	Parameter
	<1B> ₁₆	<6B> ₁₆ <31> ₁₆ (<6B> ₁₆ <32> ₁₆)	an~n
Initial value	None		
Validity and valid duration of command	When the power switch is off	The set parameter is not maintained.	
	Validity in a job	The set parameter becomes invalid.	
	Validity after a job	The set parameter becomes invalid.	

[Function]

Recalls and prints the vertically written external character registered in the printer memory.

[Format]

<k1>an~n

<k2>an~n

• Parameter

a [External character specification mode] = H: Hexadecimal character
 B: Binary code
 I: Smoothing function by Hexadecimal character
 C: Smoothing function by Binary code
 J: Highlighting function by Hexadecimal character
 D: Highlighting function by Binary code
 K: Smoothing and highlighting functions by Hexadecimal character
 E: Smoothing and highlighting functions by Binary code

b [Registration code]

<JIS code>
 H,I,J,K : "9021" ~ "907F"
 B,C,D,E : 9021H ~ 907FH

<Shift JIS code>
 H,I,J,K : "F040" ~ "F09E"
 B,C,D,E : F040H ~ F09EH

<Unicode>
 H,I,J,K : "E000" ~ "E05E"
 B,C,D,E : E000H ~ E05EH

[Example 1] Recalls 16 x 16 dots external character, Registered data in hexadecimal character of JIS

```
<A>
<T1>H21
00FF..... FF00
<Z>
```

```
<A>
<V>100<H>200<k1>H9021
<Q>2
<Z>
```

[Example 2] Recalls 24 x 24 dots external character; Registered data in binary code of Shift JIS

```
<A>
<T2>B<40>16
<00FF . . . . . FF00>16
<Z>
```

```
<A>
<V>100<H>200<k2>B<F0>16<40>16
<Q>2
<Z>
```

[Example 3] Recalls 16 x 16 dots external character, Registered data in hexadecimal code of Unicode

```
<A>
<T1>H01
00FF . . . . . FF00
<Z>
```

```
<A>
<V>100<H>200<k1>HE001
<Q>2
<Z>
```

[Note]

1. If a print error occurs, register again.
2. The external characters registered by JIS or Shift JIS cannot be recalled by Unicode. Also the external characters registered by Unicode cannot be recalled by JIS or Shift JIS.

8.35 Font

U Font (Basic size 5 x 9 dots)		ESC+U	
HEX code	ESC <1B> ₁₆	U <55> ₁₆	Parameter n~n
Initial value	None		

Validity and valid duration of command	When the power switch is off	The set parameter is not maintained.
	Validity in a job	The set parameter becomes invalid.
	Validity after a job	The set parameter becomes invalid.

[Function]

Specifies the characters in default font size of W5 x H9 dots.

[Format]

<U>n~n

- Parameter
n [Print data] = data

[Example]

```
<A>
<V>100<H>200<P>2<L>0304<U>ABCDE
<Q>2
<Z>
```

[Note]

1. U font can be set to fixed pitch only.

[Valid commands]

Print position	<V>	<H>							
Modification	<P>	<L>	<%>	<F>	<&>	</>	<0>	<WD>	<%A>
Barcode	<D><d>	<BL><d>							

U font character set

U FONT DATA

	2	3	4	5	6	7	8	9	A	B	C	D	E	F
0	0	0	P	p					-	タ	ミ			
1	!	1	A	a	q				ア	チ	ム			
2	"	2	B	b	r				イ	ツ	ヌ			
3	#	3	C	c	s				ウ	テ	エ			
4	\$	4	D	d	t				エ	ト	ヤ			
5	%	5	E	e	u				・	オ	ナ	ユ		
6	&	6	F	f	v				ヨ	カ	ニ	ヨ		
7	'	7	G	g	w				キ	ヌ	ラ			
8	<	8	H	h	x				ク	ネ	リ			
9	>	9	I	i	y				ケ	ノ	ル			
A	*	:	J	j	z				コ	ハ	シ			
B	+	;	K	k	-				サ	ビ	ロ			
C	,	<	L	l	-				シ	フ	ク			
D	-	=	M	m					ス	ヘ	ン			
E	.	>	N	n					セ	ホ	ン			
F	/	?0		o					ソ	マ	*			

This is a print sample in W5 x H9 dots, tenfold in height/width.

8.36 Font

S Font (Basic size 8 x 15 dots)	ESC+S
--	--------------

HEX code	ESC <1B> ₁₆	S <53> ₁₆	Parameter n~n
Initial value	None		

Validity and valid duration of command	When the power switch is off	The set parameter is not maintained.
	Validity in a job	The set parameter becomes invalid.
	Validity after a job	The set parameter becomes invalid.

[Function]

Specifies the characters in default font size of W8 x H15 dots.

[Format]

<S>n~n

- Parameter

n [Print data] = data

[Example]

<A>

<V>100<H>200<P>2<L>0304<S>**ABCDE**

<Q>2

<Z>

[Note]

1. S font can be set to fixed pitch only.

[Valid commands]

Print position	<V>	<H>								
Modification	<P>	<L>	<%>	<F>	<&>	</>	<0>	<WD>	<%A>	
Barcode	<D><d>	<BL><d>								

S font character set

S FONT DATA

	2	3	4	5	6	7	8	9	A	B	C	D	E	F
0	0	@	P		p				-	ヲ	ミ			
1	!	1	A	Q	a	q			ア	チ	ム			
2	"	2	B	R	b	r			イ	ツ	メ			
3	#	3	C	S	c	s			ウ	チ	モ			
4	\$	4	D	T	d	t			エ	ト	ヤ			
5	%	5	E	U	e	u			.	オ	ナ	ユ		
6	&	6	F	V	f	v			ヲ	カ	ニ	ヨ		
7	'	7	G	W	g	w			ア	キ	ヌ	ウ		
8	(8	H	X	h	x			イ	ク	ネ	リ		
9)	9	I	Y	i	y			ウ	ケ	ノ	ル		
A	*	:	J	Z	j	z			エ	コ	ハ	シ		
B	+	;	K	☺	k	-			オ	サ	ヒ	ロ		
C	,	<	L	¥	l	-			ヤ	ツ	ク	ワ		
D	-	=	M		m				ユ	ス	ハ	ソ		
E	.	>	N		n				ヨ	セ	ホ	“		
F	/	?	0		o				ツ	ソ	マ	°		

This is a print sample in W8 x H15 dots, fivefold in height/width.

8.37 Font

M Font (Basic size 13 x 20 dots)	ESC+M
---	--------------

HEX code	ESC <1B> ₁₆	M <4D> ₁₆	Parameter n~n
Initial value	None		

Validity and valid duration of command	When the power switch is off	The set parameter is not maintained.
	Validity in a job	The set parameter becomes invalid.
	Validity after a job	The set parameter becomes invalid.

[Function]

Specifies the characters in default font size of W13 x H20 dots.

[Format]

<M>n~n

- Parameter

n [Print data] = Data

[Example]

<A>
 <V>100<H>200<P>2<L>0304<M>ABCDE
 <Q>2
 <Z>

[Note]

1. M font can be set to fixed pitch only.

[Valid commands]

Print position	<V>	<H>								
Modification	<P>	<L>	<%>	<F>	<&>	</>	<0>	<WD>	<%A>	
Barcode	<D><d>	<BL><d>								

M font character set

M FONT DATA

	2	3	4	5	6	7	8	9	A	B	C	D	E	F
0	0	@	P	p					-	タ	ミ			
1	!	1	A	Q	a	q				ア	チ	ム		
2	"	2	B	R	b	r				イ	ツ	メ		
3	#	3	C	S	c	s				ウ	テ	モ		
4	\$	4	D	T	d	t				エ	ト	ヤ		
5	%	5	E	U	e	u			.	オ	ナ	ユ		
6	&	6	F	V	f	v			ヲ	カ	ニ	ヨ		
7	'	7	G	W	g	w			ア	キ	ヌ	ラ		
8	(8	H	X	h	x			イ	ク	ネ	リ		
9)	9	I	Y	i	y			ウ	ケ	ノ	ル		
A	*	:	J	Z	j	z			エ	コ	ハ	レ		
B	+	;	K	ø	k	-			オ	サ	ヒ	ロ		
C	,	<	L	¥	l	-			ヤ	シ	フ	フ		
D	=	M	½	m					ユ	ス	ヘ	ン		
E	.	>	N	¼	n				ヨ	セ	ホ	°		
F	/	?	O	¾	o				ツ	ソ	マ	°		

This is a print sample in W13 x H20 dots, fourfold in height/width.

WB font character set

WB FONT DATA

	2	3	4	5	6	7	8	9	A	B	C	D	E	F
0	0	@	P	'	p				-	タ	ミ			
1	!	1	A	Q	a	q			ア	チ	ム			
2	"	2	B	R	b	r			イ	ツ	メ			
3	#	3	C	S	c	s			ウ	テ	モ			
4	\$	4	D	T	d	t			エ	ト	ヤ			
5	%	5	E	U	e	u			.	オ	ナ	ユ		
6	&	6	F	V	f	v			ヨ	カ	ニ	ヨ		
7	'	7	G	W	g	w			ア	キ	ヌ	ラ		
8	(8	H	X	h	x			イ	ク	ネ	リ		
9)	9	I	Y	i	y			ウ	ケ	ノ	ル		
A	*	:	J	Z	j	z			エ	コ	ハ	レ		
B	+	;	K	Ø	k	-			オ	サ	ヒ	ロ		
C	,	<	L	¥	l	=			ヤ	シ	フ	ワ		
D	-	=	M	½	m				ユ	ス	ハ	ン		
E	.	>	N	¼	n	!			ヨ	セ	ホ			
F	/	?	0	%	o				ツ	ソ	マ			

This is a print sample in W18 x H30 dots, threefold in height/width.

8.39 Font

WL Font (Basic size 28 x 52 dots)	ESC+WL
--	---------------

HEX code	ESC <1B> ₁₆	WL <57> ₁₆ <4C> ₁₆	Parameter an~n
Initial value	None		

Validity and valid duration of command	When the power switch is off	The set parameter is not maintained.
	Validity in a job	The set parameter becomes invalid.
	Validity after a job	The set parameter becomes invalid.

[Function]

Specifies the characters in default font size of W28 x H52 dots.

[format]

<WL>an~n

• Parameter

- a [Smoothing] = 0: Auto-smoothing of font is disabled
1: Auto-smoothing of font is enabled
(When the Character Expansion <L> command is set between 3 and 12 times)
- n [Print data] = Data

[Example]

```
<A>
<V>100<H>200<P>2<L>0304<WL>0ABCDE
<Q>2
<Z>
```

[Note]

1. WL font can be set to fixed pitch only.
2. Auto-smoothing is only effective if the Character Expansion <L> command is at least three times in each direction.

[Valid commands]

Print position	<V>	<H>								
Modification	<P>	<L>	<%>	<F>	<&>	</>	<0>	<WD>	<%A>	
Barcode	<D><d>	<BL><d>								

WL font character set

WL FONT DATA

	2	3	4	5	6	7	8	9	A	B	C	D	E	F
0	0	@	P	'	p				-	タ	ミ			
1		1	A	Q	a	q			ア	チ	ム			
2	"	2	B	R	b	r			イ	ツ	メ			
3	#	3	C	S	c	s			ウ	テ	モ			
4	\$	4	D	T	d	t			エ	ト	ヤ			
5	%	5	E	U	e	u			.	オ	ナ	ユ		
6	&	6	F	V	f	v			ヨ	カ	ニ	ヨ		
7	'	7	G	W	g	w			ア	キ	ヌ	ラ		
8	(8	H	X	h	x			イ	ク	ネ	リ		
9)	9	I	Y	i	y			ウ	ケ	ル			
A	*	:	J	Z	j	z			エ	コ	ハ	レ		
B	+	;	K	ç	k	-			オ	サ	ヒ	ロ		
C	,	<	L	¥	l	=			ヤ	シ	フ	ク		
D	-	=	M	½	m				ユ	ス	ヘ	ン		
E	.	>	N	¼	n	!			ヨ	セ	ホ	"		
F	/	?	0	%	o				ツ	ソ	マ	°		

This is a print sample in W28 x H52 dots, twofold in height/width.

9. Barcode Command

In barcode specification, print of various barcodes, change of bar width ratio, and print of guard bar or human-readable information can be performed by designating (B, D, BD) after ESC.

This and next page should be read closely and followed.

Refer to the table below for the specification of B, D, and BD.

[Barcode ratio]

Parameter	Barcode		<D>	<BD>
0	CODABAR (NW-7)	1 : 3	1 : 2	2 : 5
1	CODE39	1 : 3	1 : 2	2 : 5
2	ITF	1 : 3	1 : 2	2 : 5
5	Industrial 2of5	1 : 3	1 : 2	2 : 5
6	Matrix 2of5	1 : 3	1 : 2	2 : 5

(1) Barcode ratio

Barcodes consist of narrow bars, wide bars, narrow spaces and wide spaces. Bar width ratio is the proportion of Narrow Bar and Wide Bar.

Bar width ratio (Ratio 1 : 3)

This barcode is composed of Narrow Bar [1] and Wide Bar [3].

Bar width ratio (Ratio 1 : 2) <D>

This barcode is composed of Narrow Bar [1] and Wide Bar [2].

Bar width ratio (Ratio 2 : 5) <BD>

This barcode is composed of Narrow Bar [2] and Wide Bar [5].

If specifying bar width ratio for your own convenience, register the ratio with the Variable Ratio Barcodes <BT> command and print labels with the Print Variable Ratio Barcodes <BW> command.

(2) Narrow bar width and barcode height

Narrow bar indicates the narrow bar width, and bar height indicates the height of barcode.

For instance, printing narrow bar for 1 dot in head density of 12 dots/mm, the narrow bar width will be 0.083mm and barcode scanner may have a reading problem. To avoid this problem, set the narrow bar to 2 dots so that the narrow bar width will be 0.166mm and this will improve the scanner reading performance.

There is a necessity to set the narrow bar width based on the printer head density or performance of barcode scanner.

In bar width ratio, [Narrow bar width] specification sets the width of bar.

e.g.) When bar width ratio = 1 : 3 and narrow bar width is 3 dots, bar width ratio becomes 3 : 9.

Bar height is to specify the height of barcode, and proper height can be set based on the scanner type.

(3) Inter-character gap

Intercharacter gap is the space between two adjacent barcode characters in a discrete barcode.

To specify and enable intercharacter gap, insert the Character Pitch <P> command right before barcode specification such as , <D> and <BD> or the Print Variable Ratio Barcodes <BW> command. If not, the initial value (2 dots) will be set.

Intercharacter gap is designable for the following barcodes.

- 1) CODABAR (NW-7)
- 2) CODE39
- 3) Industrial 2of5
- 4) Matrix 2of5

Intercharacter gap is the multiplier of values specified with the Character Pitch <P> command and narrow bar width.

Example) When the Character Pitch <P> command is 3 and narrow bar width is 2 dots:

$$\text{Intercharacter gap} = 3 \times 2 = 6 \text{ (dots)}$$

(4) Human Readable Interpretation and Guard bars

For UPC-A, JAN/EAN-8 and JAN/EAN-13 barcodes, availability of human-readable interpretation (hereinafter HRI) and guard bars can be specified.

Parameter	Barcode	Parameter 	Parameter <D>	Parameter <BD>
3	JAN/EAN13	HRI : No Guard bar : No	HRI : No Guard bar : Yes	HRI : Yes Guard bar : Yes
4	JAN/EAN8	HRI : No Guard bar : No	HRI : No Guard bar : Yes	HRI : Yes Guard bar : Yes
H	UPC-A	HRI : No Guard bar : No	HRI : No Guard bar : Yes	HRI : Yes Guard bar : Yes

(1) Specification of (No HRI, No guard bar)

Specifying prints out the barcode below.



(2) Specification of <D> (No HRI, with guard bars)

Specifying <D> prints out the barcode below.



[Note]

1. HRI is printable specifying <Character Type> data subsequently to <D>.
2. For more information, refer to the Barcode (HRI) <D>~<d> command.

(3) Specification of <BD> (HRI and guard bars available)

Specifying <BD> prints out the barcode below.



[Specifying barcode only]

Parameter	Barcode	Parameter
C	CODE93	Barcode only
E	UPC-E	Barcode only
G	CODE128	Barcode only
I	GS1-128 (UCC/EAN128) for standard carton ID	Barcode only
Z	Customer barcode	Barcode only

[Important]

1. In this case, barcodes have no bar width ratio.

(5) Check digits

Refer to table below for check digit in each barcode.

[C/D]

Parameter	Barcode	Input digits	Digits printed, information included
3	JAN/EAN-13	12	13-digit (Input data of barcode + C/D) C/D is calculated by modulus10.
		13	13-digit (Input data of barcode. C/D is not checked)
4	JAN/EAN-8	7	8-digit (Input data of barcode + C/D) C/D is calculated by modulus10.
		8	8-digit (Input data of barcode. C/D is not checked)
C	CODE93	Max. 99	C/D is calculated by modulus47.
E	UPC-E	6 (fixed)	C/D is calculated by modulus10.
G	CODE128 (128A,128B, 128C)	-	C/D is calculated by modulus103.
H	UPC-A	11 (fixed)	12-digit (Input data of barcode + C/D) C/D is calculated by modulus10.
I	GS1-128 (UCC/EAN128) for standard carton ID	17 (fixed)	C/D is calculated by modulus 103.

* C/D stands for "Check Digit".

Print Direction of Barcode

Print direction of barcodes can be changed. Note that when specifying Serial 1 and Serial 2 for barcode rotation, it may cause blurring due to barcode enlargement ratio.

In the head density 305dpi (12dot/mm), 1 dot is 0.083mm, and in 609dpi (24dot/mm), 1 dot is 0.042mm. Therefore, please try not to print a narrow bar of 1 dot ("L" indicates the enlargement ratio to the bar width ratio).

Parallel 1 : Forward feed print

Parallel 2 : Opposite of forward print

Serial 1 : Forward feed print at 90° rotation

Serial 2 : Forward feed print at 270° rotation

*** Forward feed: Prints horizontally to media feed direction**

- 1) To print with Parallel1 and Parallel2, specify proper enlargement ratio of bar width to make a narrow bar 2 dots and upwards. ("L" indicates the enlargement ratio to the bar width ratio.)

	Head density	
	12 dots/mm	24 dots/mm
Bar width ratio 1:2	2L or more	4L or more
Bar width ratio 1:3	2L or more	4L or more
Bar width ratio 2:5	1L or more	2L or more
UPC-A, JAN/EAN	2L or more	4L or more

- 2) To print with Serial1 and Serial2, specify proper enlargement ratio of bar width to make a narrow bar 3 dots and upwards.

	Head density	
	12 dot/mm	24 dot/mm
Bar width ratio 1:2	3L or more	6L or more
Bar width ratio 1:3	3L or more	6L or more
Bar width ratio 2:5	2L or more	4L or more
UPC-A, JAN/EAN	3L or more	6L or more

- 3) To print with Serial1 and Serial2, drop print speed.

9.1 Barcode

Barcode (Ratio 1:3)		ESC+B	
HEX code	ESC <1B> ₁₆	B <42> ₁₆	Parameter abbcccn~n
Initial value	None		

Validity and valid duration of command	When the power switch is off	The set parameter is not maintained.
	Validity in a job	The set parameter becomes invalid.
	Validity after a job	The set parameter becomes invalid.

[Function]

Specifies the barcode of narrow and wide bar width ratio 1:3.

[Format]

abbcccn~n

• Parameter

- a [Barcode symbology] = Refer to the table below.
- b [Narrow bar width] = 01 to 12 dots
- c [Height of barcode] = 001 to 600 dots
- n [Print data] = Data

Barcode symbology (Ratio of module composition may not be available depending on the barcode symbology.)

a	Barcode symbology	Descriptions	Ratio
0	CODABAR(NW-7)	Set print data including Start/Stop characters. Start/Stop Characters are [A,B,C,D,E,N,T,a,b,c,d,e,n,t]. e.g.) When barcode print data is [123], specify [A123A]. Barcode character pitch is enabled.	1:3
1	CODE39	Set print data including Start/Stop Characters. Start/Stop Characters are indicated as [*]. e.g.) When barcode print data is [12345], specify [*12345*]. Barcode character pitch is enabled.	1:3
2	ITF	Specify print data in even-numbered digit. If specifying in odd-numbered digit, "0" is added to the head of print data.	1:3
3	JAN/EAN-13	Barcodes have no guard bars and HRI.	Fixed
4	JAN/EAN-8	Barcodes have no guard bars and HRI.	Fixed
5	Industrial 2of5	Barcode character pitch is enabled.	1:3
6	Matrix 2of5	Barcode character pitch is enabled.	1:3
C	CODE93	Refer to the CODE93<BC> command.	Fixed
E	UPC-E	Specify 6-digit number for print data.	Fixed
F	UPC add-on code	Refer to the UPC Add-on Code <BF> command.	Fixed
G	CODE128	Refer to the CODE128<BG> for print data.	Fixed
H	UPC-A	Specify 11-digit number for print data. Barcodes have no guide bars and HRI.	Fixed
I	GS1-128(UCC/EAN128)	Refer to the GS1-128(UCC/EAN128)<BI> command.	Fixed
Z	Customer barcode	Refer to the Customer Barcode <BZ> command.	Fixed

[Example 1] Barcode symbology: CODE39, Narrow bar width: 03, Height of barcode:120, Print data: *1234AB*
<A>
<V>100<H>100103120*1234AB*
<Q>2
<Z>

[Example 2] Barcode symbology: JAN8, Narrow bar width: 02, Height of barcode: 080, Print data: 4912345
<A>
<V>100<H>1004020804912345
<Q>2
<Z>

[Note]

- Barcode character pitch can be specified for CODABAR(NW-7), CODE39, Industrial 2of5 and Matrix 2of5.
To specify barcode character pitch, insert the Character Pitch <P> command right before barcode symbology. When <P> is omitted, character pitch will be as same as narrow space width.
e.g.) Character pitch specification (None or 0, 1) x Narrow bar width (2dots) = Character pitch (2dots)
Character pitch specification (2) x Narrow bar width (3dots) = Character pitch (6dots)
- As for the print data of barcode symbologies, refer to each barcode table.

[Tip]

- If the value other than valid range is set, command error will occur and barcode will not be printed.
- Barcode outside the printable area will not be printed.
- Increasing narrow bar width may exceed the print area and may not print properly.
- Scanner may not read the barcode with valid character pitch when the Character Pitch <P> command is increased.
Also, increasing the narrow bar width may cause the same type of problem. For more information, refer to the documentation of your scanner.
- Set the narrow bar width to 2 dots or more considering the reading compatibility of scanner beforehand.
- Adjust the Print Speed <CS> command or the Print Darkness <#E> command in case of scanner reading problem.
- Matrix 2of5 will be indicated by Coop2of5/NEC2of5.
- If Start/Stop characters are not included in print data in the specification of CODABAR(NW-7) or CODE39, a scanner can not read the printed barcodes.
- If sending the print data including check digit in the specification of JAN/EAN-13 or JAN/EAN-8, set the correct calculated value. Barcodes can be printed even when the print data includes improper check digit, but a scanner can not read the printed barcodes.

9.2 Barcode

Barcode (Ratio 1:2)	ESC+D
----------------------------	--------------

HEX code	ESC <1B> ₁₆	D <44> ₁₆	Parameter abbcccn~n
Initial value	None		

Validity and valid duration of command	When the power switch is off	The set parameter is not maintained.
	Validity in a job	The set parameter becomes invalid.
	Validity after a job	The set parameter becomes invalid.

[Function]

Specifies the barcode of narrow and wide bar width ratio 1:2.

[Format]

<D>abbcccn~n

• Parameter

- a [Barcode symbology] = Refer to the table below
- b [Narrow bar width] = 01 to 12 dots
- c [Height of barcode] = 001 to 600 dots
- n [Print data] = Data

Barcode symbology (Ratio of module composition may not be available depending on the barcode symbology)

a	Barcode symbology	Description	Ratio
0	CODABAR (NW-7)	Set print data including Start/Stop Characters. Start/Stop Characters are [A,B,C,D,E,N,T,a,b,c,d,e,n,t]. e.g.) When barcode print data is [123], specify [A123A]. Barcode character pitch is enabled.	1:2
1	CODE39	Set print data including Start/Stop Characters. Start/Stop Characters are indicated as [*]. e.g.) When barcode print data is [12345], specify [*12345*]. Barcode character pitch is enabled.	1:2
2	ITF	Specify print data in even-numbered digit. If specifying in odd-numbered digit, "0" is added to the head of print data.	1:2
3	JAN/EAN13	Barcodes have guard bars, but no HRI.	Fixed
4	JAN/EAN8	Barcodes have guard bars, but no HRI.	Fixed
5	Industrial 2of5	Barcode character pitch is enabled.	1:2
6	Matrix 2of5	Barcode character pitch is enabled.	1:2
H	UPC-A	Specify print data in 11-digit number. Barcodes have guard bars, but no HRI.	Fixed

[Example 1] Barcode symbology: CODABAR (NW-7), Narrow bar width: 03, Height of barcode: 120, Print data: A1234A

<A>
<V>100<H>100<D>003120A1234A
<Q>2
<Z>

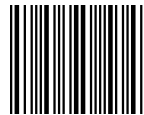

[Example 2] Barcode symbology: ITF, Narrow bar width: 02, Height of barcode: 080, Print data: 98002345678163

<A>
<V>100<H>100<D>20208098002345678163
<Q>2
<Z>



[Example 3] Barcode symbology: UPC-A, Narrow bar width: 03, Height of barcode: 120, Print data: 20123948573

<A>
<V>240<H>100<D>H0312020123948573
<Q>2
<Z>



[Note]

1. Barcode character pitch can be specified for CODABAR(NW-7), CODE39, Industrial 2of5 and Matrix 2of5.
To specify barcode character pitch, insert the Character Pitch <P> command right before barcode symbology. When <P> is omitted, character pitch will be as same as narrow space width.
e.g.) Character pitch specification (Nil or 0, 1) x Narrow bar width (2dots) = Character pitch (2dots)
Character pitch specification (2) x Narrow bar width (3dots) = Character pitch (6dots)
2. As for the print data of barcode symbologies, refer to each barcode table.

[Tip]

1. If the value other than valid range is set, command error will occur and barcode will not be printed.
2. Barcode outside the printable area will not be printed.
3. Increasing narrow bar width may exceed the print area and may not print properly.
4. Scanner may not read the barcode with valid character pitch when the Character Pitch <P> command is increased.
Also, increasing the narrow bar width may cause the same type of problem. For more information, refer to the documentation of your scanner.
5. Set the narrow bar width to 2 dots or more considering the reading compatibility of scanner beforehand.
6. Adjust the Print Speed <CS> command or the Print Darkness <#E> command in case of scanner reading problem.
7. Matrix 2of5 will be indicated by Coop2of5/NEC2of5.
8. If Start/Stop characters are not included in print data in the specification of CODABAR(NW-7) or CODE39, a scanner can not read the printed barcodes.
9. If sending the print data including check digit in the specification of JAN/EAN-13 or JAN/EAN-8, set the correct calculated value. Barcodes can be printed even when the print data includes improper check digit, but a scanner can not read the printed barcodes.

9.3 Barcode			
Barcode (HRI)			ESC+D ~ ESC+d
HEX code	ESC	D~+ ESC+d	Parameter
	<1B> ₁₆	<44> ₁₆ ~<1B> ₁₆ font type	abbcccn~n + <d>n~n
Initial value	None		
Validity and valid duration of command	When the power switch is off	The set parameter is not maintained.	
	Validity in a job	The set parameter becomes invalid.	
	Validity after a job	The set parameter becomes invalid.	

[Function]

Specifies the font type of human readable interpretation (HRI) for barcode.

[Format]

<D>abbcccn~n + <d>n~n

• Parameter

- a [Barcode symbology] = 3 : JAN/EAN-13
4 : JAN/EAN-8
H : UPC-A
- b [Narrow bar width] = 01 to 12 dots
- c [Height of barcode] = 001 to 600 dots
- n [Print data] = Barcode data
- d [Font type specification] = OA
OB
X20
X21
X22
X23
X24
- n [Print data] = HRI data

[Example] Barcode symbology: JAN/EAN-13, Narrow bar width: 03, Height of barcode: 120,
Barcode data: 4902471000793, Font type: X20, HRI data: 4902471000793

<A>
<V>100<H>200<D>**3031204902471000793**
<X20>,4902471000793
<Q>2
<Z>



[Note]

1. Adds HRI in specified character type.
2. When the data other than specified value is set, printing will not be performed. When barcode enlargement ratio is small and character type is large, HRI may be overlapped with each other.
3. Printer will lay out HRI properly.
4. The following conditions are appropriate for the HRI of JAN/EAN-8, JAN/EAN-13 and UPC-A.
 - 12 dots/mm : Appropriate narrow bar width is [03], [04]
 - 24 dots/mm : Appropriate narrow bar width is [06], [07], [08]

9.4 Barcode

Barcode (Ratio 2:5)		ESC+BD	
----------------------------	--	---------------	--

HEX code	ESC <1B> ₁₆	BD <42> ₁₆ <44> ₁₆	Parameter abbcccn~n
Initial value	None		

Validity and valid duration of command	When the power switch is off	The set parameter is not maintained.
	Validity in a job	The set parameter becomes invalid.
	Validity after a job	The set parameter becomes invalid.

[Function]

Specifies the barcode of narrow and wide bar width ratio 2:5.

[Format]

<BD>abbcccn~n

• Parameter

a	[Barcode symbology]	=	Refer to table below
b	[Narrow bar width]	=	01 to 12 dots
c	[Height of barcode]	=	001 to 600 dots
n	[Print data]	=	Data

Barcode symbology (Ratio of module composition may not be available depending on the barcode symbology.)

a	Barcode symbology	Description	Ratio
0	NW-7 (Codabar)	Set print data including Start/Stop Characters. Start/Stop Characters are [A,B,C,D,E,N,T,a,b,c,d,e,n,t]. e.g.) When barcode print data is [123], specify [A123A]. Barcode character pitch is enabled.	2:5
1	CODE39	Set print data including Start/Stop Character. Start/Stop Characters are [*]. e.g.) When barcode print data is [12345], specify [*12345*]. Barcode character pitch is enabled.	2:5
2	ITF	Specify print data in even-numbered digit. If specifying in odd-numbered digit, "0" is added to the head of print data.	2:5
3	JAN/EAN-13	Barcode have guard bars and HRI.	Fixed
4	JAN/EAN-8	Barcodes have guard bars and HRI.	Fixed
5	Industrial 2of5	Barcode character pitch is enabled.	2:5
6	Matrix 2of5	Barcode character pitch is enabled.	2:5
H	UPC-A	Specify print data in 11-digit number. Barcodes have guard bars and HRI.	Fixed

[Example 1] Barcode symbology: CODABAR(NW-7), Narrow bar width: 03, Height of barcode: 120
Print data: A1234A

```
<A>
<V>100<H>100<BD>003120A1234A
<Q>2
<Z>
```



[Example 2] Barcode symbology: ITF, Narrow bar width: 02, Height of barcode: 120
Print data: 98002345678163

```
<A>
<V>100<H>100<BD>20212098002345678163
<Q>2
<Z>
```



[Example 3] Barcode symbology: UPC-A, Narrow bar width: 03, Height of barcode: 120
Print data: 20123948573

```
<A>
<V>240<H>100<BD>H0312020123948573
<Q>2
<Z>
```



[Note]

- Barcode character pitch is available for CODABAR(NW-7), CODE39, Industrial 2of5 and Matrix 2of5. To specify barcode character pitch, insert Character Pitch <P> right before barcode symbology. When <P> is omitted, character pitch will be as same as narrow space width.

Example)

Command	Ratio	Narrow space width	<P>	Intercharacter gap	
				When narrow bar width is [1]	When narrow bar width is [2]
<BD>	2:5	2	None	2	4
			<P>0	2	4
			<P>1	1	2
			<P>2	2	4
			<P>3	3	6
			<P>4	4	8

- As for the print data of barcode symbologies, refer to each barcode table.
- The following conditions are appropriate for the HRI of JAN/EAN-8, JAN/EAN-13 and UPC-A.
 - 305dpi (12 dot/mm): Print operation occurs only when narrow bar width is set to [03] and [04] dots.
 - 609dpi (24 dot/mm): Print operation occurs only when narrow bar width is set to [06], [07], and [08] dots.

[Tip]

- If the value other than valid range is set, command error will occur and barcode will not be printed.
- Barcode outside the printable area will not be printed.
- Increasing narrow bar width may exceed the print area and may not print properly.
- Scanner may not read the barcode with valid character pitch when the Character Pitch <P> command is increased. Also, increasing the narrow bar width may cause the same type of problem. For more information, refer to the documentation of your scanner.
- Set the narrow bar width considering the reading compatibility of scanner and the head density.
- Adjust the Print Speed <CS> command or the Print Darkness <#E> command in case of scanner reading problem.
- Matrix 2of5 will be indicated by Coop2of5/NEC2of5.
- If Start/Stop characters are not included in print data in the specification of CODABAR(NW-7) or CODE39, a scanner cannot read the printed barcodes.
- If sending the print data including check digit in the specification of JAN/EAN-13 or JAN/EAN-8, set the correct calculated value. When the data includes improper check digit; a scanner cannot read the printed barcodes.

9.5 Barcode			
Variable Ratio Barcode			ESC+BT
HEX code	ESC	BT	Parameter
	<1B> ₁₆	<42> ₁₆ <54> ₁₆	abbccddee
Initial value	None		
Validity and valid duration of command	When the power switch is off	The set parameter is not maintained.	
	Validity in a job	The set parameter becomes invalid.	
	Validity after a job	The set parameter becomes invalid.	

[Function]

Specifies the bar width ratio of narrow and wide bars.

[Format]

<BT>abbccddee

• Parameter

a	[Barcode symbology]	=	0	:	CODABAR (NW-7)
			1	:	CODE39
			2	:	ITF
			5	:	Industrial 2of5
			6	:	Matrix 2of5 (Coop2of5 / NEC2of5)
b	[Narrow space]	=	01 to 99 dots		
c	[Wide space]	=	01 to 99 dots		
d	[Narrow bar]	=	01 to 99 dots		
e	[Wide bar]	=	01 to 99 dots		

[Example 1] Barcode symbology: CODE39, Narrow space: 03 Wide space: 05
Narrow bar: 03, Wide bar: 05

```
<A>
<BT>103050305
<V>100<H>200<BW>03120*ABCD*
<Q>2
<Z>
```

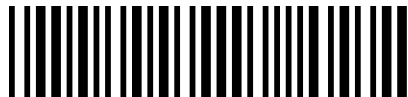

[Note]

1. Only one ratio can be registered.
2. To print barcode with specified ratio, insert Print of Barcode with the Print Variable Ratio Barcodes <BW> command after this command.
3. When <BW> and the Print Quantity <Q> command are not specified, only the registration of bar width ratio of narrow and wide bars can be performed.
4. If the data other than specified is set, this will not be registered due to command error.
5. Matrix 2of5 will be indicated by Coop2of5/NEC2of5.

9.6 Barcode

Print of Variable Ratio Barcodes	ESC+BW
---	---------------

HEX code	ESC <1B> ₁₆	BW <42> ₁₆ <57> ₁₆	Parameter aabbn~n
Initial value	None		

Validity and valid duration of command	When the power switch is off	The set parameter is not maintained.
	Validity in a job	The set parameter becomes invalid.
	Validity after a job	The set parameter becomes invalid.

[Function]

Specifies the barcode registered with the Variable Ratio Barcodes <BT> command.

[Format]

<BW>aabbn~n

• Parameter

- a [Narrow bar width] = 01 to 12 dots
- b [Height of barcode] = 001 to 600 dots
- n [Print data] = Barcode data

[Example] Narrow bar width: 02, Height of barcode: 120

```
<A>
<BT>103050305
<V>100<H>200<BW>02120*ABCD*
<Q>2
<Z>
```

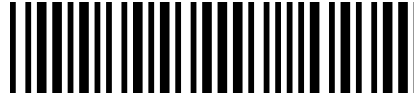

[Note]

- Barcode character pitch is available for CODABAR(NW-7), CODE39, Industrial 2of5 and Matrix 2of5. To specify barcode character pitch, insert the Character Pitch <P> command right before barcode symbology.
When <P> is omitted, character pitch will be equal to narrow space width.

e.g.1) When the narrow space value by <BT> is [3]:
Character pitch specification (None or 0, 3) x Narrow bar width (2dots) = Character pitch (6dots)
e.g.2) When the character pitch is specified:
Character pitch specification (2) x Narrow bar width (3dots) = Character pitch (6dots)
- If there is no Variable Ratio Barcode <BT> command, the barcode based on pre-registered bar width ratio of narrow and wide bars will be printed. Note that specification of <BT> is required to perform print operation.
- For print data of barcode symbology, refer to the code table of each barcode.

[Tip]

- If the value other than valid range is set, command error will occur and barcode will not to be printed.
- Barcode outside the printable area will not be printed.
- Increasing narrow bar width may exceed the print area and may not print properly.
- Scanner may not read the barcode with valid character pitch when the Character Pitch <P> command is increased.
Also, increasing the narrow bar width may cause the same type of problem. For more information, refer to the documentation of your scanner.
- For specifying the narrow bar width, consider the reading compatibility of scanner and the head density.
- Adjust the Print Speed <CS> or Print Darkness <#E> commands in case of scanner reading problem.
- Matrix 2of5 will be indicated by Coop2of5/NEC2of5.
- If Start/Stop characters are not included in print data in the specification of CODABAR(NW-7) or CODE39, a scanner cannot read the printed barcodes.

CODABAR (NW-7) code table

				S				I				S				O							
b8				0	0	0	0	0	0	0	0	0	0	0	0	1	1	1	1	1	1	1	1
b7				0	0	0	0	1	1	1	1	0	0	0	0	1	1	1	1	1	1	1	1
b6				0	0	1	1	0	0	1	1	0	0	1	1	0	0	1	1	0	0	1	1
b5				0	1	0	1	0	1	0	1	0	1	0	1	0	1	0	1	0	1	0	1
b4	b3	b2	b1		0	1	2	3	4	5	6	7	8	9	A	B	C	D	E	F			
0	0	0	0	0			SP	0															
0	0	0	1	1				1	A		a												
0	0	1	0	2				2	B		b												
0	0	1	1	3				3	C		c												
0	1	0	0	4			\$	4	D	T	d	t											
0	1	0	1	5				5	E		e												
0	1	1	0	6				6															
0	1	1	1	7				7															
1	0	0	0	8				8															
1	0	0	1	9				9															
1	0	1	0	A			*	:															
1	0	1	1	B			+																
1	1	0	0	C																			
1	1	0	1	D			-																
1	1	1	0	E			.		N		n												
1	1	1	1	F			/																

CODE39 code table

				S				I				S				O							
b8				0	0	0	0	0	0	0	0	0	0	0	0	1	1	1	1	1	1	1	1
b7				0	0	0	0	1	1	1	1	1	1	0	0	0	0	1	1	1	1	1	1
b6				0	0	1	1	0	0	1	1	0	0	1	1	0	0	1	1	0	0	1	1
b5				0	1	0	1	0	1	0	1	0	1	0	1	0	1	0	1	0	1	0	1
b4	b3	b2	b1	0	1	2	3	4	5	6	7	8	9	A	B	C	D	E	F				
0	0	0	0	0			SP	0		P													
0	0	0	1	1				1	A	Q													
0	0	1	0	2				2	B	R													
0	0	1	1	3				3	C	S													
0	1	0	0	4			\$	4	D	T													
0	1	0	1	5			%	5	E	U													
0	1	1	0	6				6	F	V													
0	1	1	1	7				7	G	W													
1	0	0	0	8				8	H	X													
1	0	0	1	9				9	I	Y													
1	0	1	0	A			*		J	Z													
1	0	1	1	B			+		K														
1	1	0	0	C					L														
1	1	0	1	D			-		M														
1	1	1	0	E			.		N														
1	1	1	1	F			/		O														

9.7 Barcode			
GS1-128 (UCC/EAN128) <For standard carton ID>			ESC+BI
HEX code	ESC	BI	Parameter
	<1B> ₁₆	<42> ₁₆ <49> ₁₆	aabbbcn~n
Initial value	None		
Validity and valid duration of command	When the power switch is off	The set parameter is not maintained.	
	Validity in a job	The set parameter becomes invalid.	
	Validity after a job	The set parameter becomes invalid.	

[Function]
Specifies GS1-128 (UCC/EAN128) for standard carton ID.

[Format]
<BI>aabbbcn~n

•Parameter

a	[Narrow bar width]	=	01 to 12 dots
b	[Height of barcode]	=	001 to 600 dots
c	[HRI font]	=	0 : No HRI 1 : HRI is available (Top of barcode) 2 : HRI is available (Bottom of barcode)
n	[Print data]	=	Barcode data (17 digits fixed)

See the GS-128 (UCC/EAN128) code table on the following page.
EAN128 (Barcode for standard carton ID)

- Identifier of a continuous code for freight packaging
- Type of packaging
- Country, manufacturer code
- Serial number for shipping container
- C/D

* Check digit is automatically added, therefore, specify data in 17 digits excluding check digit.

[Example] Narrow bar width: 05, Height of barcode: 080mHRI: Available (Bottom of barcode)
Print data: 12345678901234567

<A>
<V>100<H>200<BI>05080212345678901234567
<Q>2
<Z>



- [Note]
1. UCC128 code is exclusive to Standard Carton ID. When printing in EAN128, designed for the markets in the medical, fresh food, or flowers and plants, use the CODE128 Barcode <BG> command to specify print data by the application identification or the separator that matches each specification.
 2. Start character code, function character, end character code, and identification code (corresponds to [00] only) are added automatically.
 3. Modulus 10 check character and modulus 103 check character are automatically generated.
 4. Sequential numbering of barcode data is available.
 5. Line pitch between barcode and HRI font is fixed at 10 dots.
 6. If the width of HRI font is wider than that of barcode, it starts printing from the print start position of barcode.
 7. If the width of HRI font is narrower than that of barcode, HRI font will be aligned to the center of barcode for printing.
 8. Prints HRI font in OCR-B.
 9. If HRI font is outside of print area, it will not be printed. When selecting [HRI is available], specify the Vertical Print Position <V> and Horizontal Print Position <H> commands in consideration of print of HRI font.

ITF
 Matrix2of5
 Industrial2of5
 UPC-A,JAN/EAN-8
 JAN/EAN-13,UPC-E
 GS1-128 (UCC/EAN128)

				S				I				S				O				
				b8	0	0	0	0	0	0	0	0	1	1	1	1	1	1	1	1
				b7	0	0	0	0	1	1	1	1	0	0	0	0	1	1	1	1
				b6	0	0	1	1	0	0	1	1	0	0	1	1	0	0	1	1
				b5	0	1	0	1	0	1	0	1	0	1	0	1	0	1	0	1
b4	b3	b2	b1		0	1	2	3	4	5	6	7	8	9	A	B	C	D	E	F
0	0	0	0	0				0												
0	0	0	1	1				1												
0	0	1	0	2				2												
0	0	1	1	3				3												
0	1	0	0	4				4												
0	1	0	1	5				5												
0	1	1	0	6				6												
0	1	1	1	7				7												
1	0	0	0	8				8												
1	0	0	1	9				9												
1	0	1	0	A																
1	0	1	1	B																
1	1	0	0	C																
1	1	0	1	D																
1	1	1	0	E																
1	1	1	1	F																

9.8 Barcode			
CODE93		ESC+BC	
HEX code	ESC <1B> ₁₆	BC <42> ₁₆ <43> ₁₆	Parameter aabbccn~n
Initial value	None		
Validity and valid duration of command	When the power switch is off	The set parameter is not maintained.	
	Validity in a job	The set parameter becomes invalid.	
	Validity after a job	The set parameter becomes invalid.	

[Function]

Specifies CODE93 Barcode.

[Format]

<BC>aabbccn~n

•Parameter

- a [Narrow bar width] = 01 to 12 dots
- b [Height of barcode] = 001 to 600ts
- c [Digit No. of data] = 1 to 99
- n [Print data] = Barcode data (Refer to the CODE93 Code Table)

[Example] Narrow bar width: 02, Height of barcode: 120, Digit No. of data: 12, Print data: ABCD123456xy

<A>
 <V>100<H>200<BC>0212012ABCD123456xy
 <Q>2
 <Z>



[Note]

1. C/D is an auto-generation.
2. Maximum digit number of data is 99.
3. [Digit No. of data] and No. of input data have to be equal.
4. Command error will occur when No. of input data and [Digit No. of data] are not equal.

CODE93 Code table

					S				I				S				O					
					b8	0	0	0	0	0	0	0	0	0	1	1	1	1	1	1	1	1
					b7	0	0	0	0	1	1	1	1	0	0	0	0	1	1	1	1	
					b6	0	0	1	1	0	0	1	1	0	0	1	1	0	0	1	1	
					b5	0	1	0	1	0	1	0	1	0	1	0	1	0	1	0	1	
b4	b3	b2	b1		0	1	2	3	4	5	6	7	8	9	A	B	C	D	E	F		
0	0	0	0	0			SP	0	@	P	`	p										
0	0	0	1	1			!	1	A	Q	a	q										
0	0	1	0	2			"	2	B	R	b	r										
0	0	1	1	3			#	3	C	S	c	s										
0	1	0	0	4			\$	4	D	T	d	t										
0	1	0	1	5			%	5	E	U	e	u										
0	1	1	0	6			&	6	F	V	f	v										
0	1	1	1	7			'	7	G	W	g	w										
1	0	0	0	8			(8	H	X	h	x										
1	0	0	1	9)	9	I	Y	i	y										
1	0	1	0	A			*	:	J	Z	j	z										
1	0	1	1	B			+	;	K	[k	{										
1	1	0	0	C			,	<	L	¥	l											
1	1	0	1	D			-	=	M]	m	}										
1	1	1	0	E			.	>	N	^	n	~										
1	1	1	1	F			/	?	O	_	o	DE L										

CODE93 is settable within the range of 00H to 7FH.

9.9 Barcode			
CODE128		ESC+BG	
HEX code	ESC <1B> ₁₆	BG <42> ₁₆ <47> ₁₆	Parameter aabbbn~n
Initial value	None		
Validity and valid duration of command	When the power switch is off	The set parameter is not maintained.	
	Validity in a job	The set parameter becomes invalid.	
	Validity after a job	The set parameter becomes invalid.	

[Function]

Specifies CODE128 barcode.

[Format]

<BG>aabbbn~n

•Parameter

a [Narrow bar width] = 01 to 12 dots
 b [Height of barcode] = 001 to 600 dots
 n [Print data] = Barcode data (see code table on the following page)

[Example] Narrow bar width: 02, Height of barcode: 120, Print data: ABCD123456 (START CODE A)

<A>
 <V>100<H>200<BG>02120<G>ABCD123456
 <Q>2
 <Z>



[Note]

- Specify [START CODE] at the head of print data.
 - START CODE A = [>G]
 - START CODE B = [>H]
 - START CODE C = [>I]
- C/D is an auto-generation.
- When using "START CODE C", specify print data in even-numbered digit.
- When "START CODE C" is set to print data in odd-numbered digit, specify "START CODE A" or "B" to change the first one character of print data. And then specify the rest of data with "Code Set Character C" to change it to even-numbered digit.

Example 1) 15 digits [123456789012345] : 1<C>23456789012345

Example 2) 9 digits / Alphanumeric 6 digits [123456789ABC123] : <C>123456789ABC123
- If using "START CODE C" to specify odd-numbered digit, "0" is added to the tail of print data before printing.
- When START CODE is omitted, START CODE B is added.

CODE128 Code table

Value	Code A	Code B	Code C
0	SP	SP	00
1	!	!	01
2	"	"	02
3	#	#	03
4	\$	\$	04
5	%	%	05
6	&	&	06
7	'	'	07
8	((08
9))	09
10	*	*	10
11	+	+	11
12	,	,	12
13	-	-	13
14	.	.	14
15	/	/	15
16	0	0	16
17	1	1	17
18	2	2	18
19	3	3	19
20	4	4	20
21	5	5	21
22	6	6	22
23	7	7	23
24	8	8	24
25	9	9	25
26	:	:	26
27	;	;	27
28	<	<	28
29	=	=	29
30	> (IMPORTANT 4)	> (IMPORTANT 4)	30
31	?	?	31
32	@	@	32
33	A	A	33
34	B	B	34
35	C	C	35
36	D	D	36
37	E	E	37
38	F	F	38
39	G	G	39
40	H	H	40
41	I	I	41
42	J	J	42
43	K	K	43
44	L	L	44
45	M	M	45
46	N	N	46
47	O	O	47
48	P	P	48

Value	Code A	Code B	Code C
49	Q	Q	49
50	R	R	50
51	S	S	51
52	T	T	52
53	U	U	53
54	V	V	54
55	W	W	55
56	X	X	56
57	Y	Y	57
58	Z	Z	58
59	[[59
60	\	\	60
61]]	61
62	^	^	62
63	_	_	63
64	NUL >SP	' >SP	64
65	SOH >!	a >!	65
66	STX >v	b >v	66
67	ETX >#	c >#	67
68	EOT >\$	d >\$	68
69	ENQ >%	e >%	69
70	ACK >&	f >&	70
71	BEL >v	g >v	71
72	BS >(\	h >(\	72
73	HT >)	i >)	73
74	LF >*	j >*	74
75	VT >+	k >+	75
76	FF >.	l >.	76
77	CR >-	m >-	77
78	SO >.	n >.	78
79	SI >/	o >/	79
80	DLE >0	p >0	80
81	DC1 >1	q >1	81
82	DC2 >2	r >2	82
83	DC3 >3	s >3	83
84	DC4 >4	t >4	84
85	NAK >5	u >5	85
86	SYN >6	v >6	86
87	ETB >7	w >7	87
88	CAN >8	x >8	88
89	EM >9	y >9	89
90	SUB >:	z >:	90
91	ESC >;	{ >;	91
92	FS >X	>X	92
93	GS >=	} >=	93
94	RS >>	~ >>	94
95	US >?	DEL >?	95
96	FNC3 >@	FNC3 >@	96
97	FNC2 >A	FNC2 >A	97

Value	Code A	Code B	Code C
98	SHIFT >B	SHIFT >B	98
99	Code—C >C	Code—C >C	99
100	Code—B >D	FNC4 >D	Code—B >D
101	FNC4 >E	Code—A >E	Code—A >E
102	FNC1 >F	FNC1 >F	FNC1 >F
103	START CODE A >G		
104	B >H		
105	C >I		

[Important]

1. Send [START CODE] by all means.
2. [STOP CODE] will be automatically added in the internal printer.
3. For the specification of code higher than Value 64 in Code A and B, specify the code as two-character code which ">" is added.
4. [>] is described as [>J].

9.10 Barcode			
Customer Barcode			ESC+BZ
HEX code	ESC <1B> ₁₆	BZ <42> ₁₆ <5A> ₁₆	Parameter aaaaaaaa,n~n
Initial value	None		
Validity and valid duration of command	When the power switch is off	The set parameter is not maintained.	
	Validity in a job	The set parameter becomes invalid.	
	Validity after a job	The set parameter becomes invalid.	

[Function]
Specifies customer barcode.

[Format]
<BZ>aaaaaaaa,n - n

- Parameter
 - a [Postal code] = Numeric : 0000000 to 9999999 [7 digits fixed]
 - n [Print data] = Data (Address Number) [Max. 13digits]

(See the customer barcode code table on the following page)

[Example] Postal code: 3310043, Print data: 1-207
<A>
<V>100<H>200<BZ>3310043,1-207
<Q>2
<Z>



[Note]

- Only alphanumeric and hyphen (-) can be specified as print data (Refer to the code table on the following page).
- Start/Stop characters and check digit are automatically added.
- When the digit number of print data is shorter than 13 digits, the control code (C4) will be automatically added.
When the digit number of print data is longer than 13 digits, the data after the 14th digit will be invalid.
- When specifying alphanumeric for print data, 1 alphabetical letter (for control code) + the numeric code will be processed as 2-digit data.
When specifying 10 alphabetical letters [ABCDEFGHIJ], the first 6 letters [ABCDEF] will be processed as 12-digit data (Control code + 2-digit numeric code x 6 letters = 12-digit data). As for the 7th letter [G], control code + numeric code will be 13-digit or less; therefore, the control code will be valid, but not the numeric code which is the 14th digit. As for the 8th digit and after [HIJ], they will be invalid as they are not within 13 digits.

Example) For [ABCDEFGHIJ]

- (1) [ABCDEF] : 6 letters x 2-digit (Control code + numeric code) = 12 digits
The data of 6 letters are all valid.
 - (2) [G] : 1 letter x 2 digits (Control code + numeric code) = 2 digits
In 1 letter, up to control code will be within 13 digits and become valid. Numeric code will be the 14th digit and become invalid.
 - (3) [HIJ] : 3 letters x 2 digits (Control code + numeric code) = 6 digits
All invalid as both control and numeric codes are over 14 digits.
- When specifying the parameter other than specified or when the number of print data is not correct, the barcode may not be printed properly or may not be read by the scanner.

Customer barcode table

					S				I				S				O					
b8					0	0	0	0	0	0	0	0	0	1	1	1	1	1	1	1	1	1
b7					0	0	0	0	1	1	1	1	0	0	0	0	1	1	1	1	1	1
b6					0	0	1	1	0	0	1	1	0	0	1	1	0	0	1	1	1	1
b5					0	1	0	1	0	1	0	1	0	1	0	1	0	1	0	1	0	1
b4	b3	b2	b1		0	1	2	3	4	5	6	7	8	9	A	B	C	D	E	F		
0	0	0	0	0				0		P												
0	0	0	1	1				1	A	Q												
0	0	1	0	2				2	B	R												
0	0	1	1	3				3	C	S												
0	1	0	0	4				4	D	T												
0	1	0	1	5				5	E	U												
0	1	1	0	6				6	F	V												
0	1	1	1	7				7	G	W												
1	0	0	0	8				8	H	X												
1	0	0	1	9				9	I	Y												
1	0	1	0	A					J	Z												
1	0	1	1	B					K													
1	1	0	0	C					L													
1	1	0	1	D			-		M													
1	1	1	0	E					N													
1	1	1	1	F					O													

9.11 Barcode

UPC Add-On Barcode	ESC+BF
---------------------------	---------------

HEX code	ESC	BF	Parameter
	<1B> ₁₆	<42> ₁₆ <46> ₁₆	aabbbn~n
Initial value	None		

Validity and valid duration of command	When the power switch is off	The set parameter is not maintained.
	Validity in a job	The set parameter becomes invalid.
	Validity after a job	The set parameter becomes invalid.

[Function]

Specifies UPC add-on barcode.

[Format]

<BF>aabbbn~n

●Parameter

a [Narrow bar width] = 01 to 12 dots
 b [Height of barcode] = 001 to 600 dots
 n [Print data] = Numeric 2-digit, 5-digit

[Example 1] Barcode symbology: Add-on code Narrow bar width: 03 Height of barcode: 120

```
<A>
<H>325<V>725<BD>H0315009827721123
<H>640<V>760<BF>0312021826
<H>655<V>730<OB>21826
<Q>1
<Z>
```



[Note]

- Barcode will not be printed when specifying 2 digits or 5 digits for print data.
- Only numeric can be used to specify the print data.
- Specification of automatic HRI is not available.
- When printing the data by this command only, the data cannot be scanned.
 Only when printing the data by the combination of UPC code set and this command, the data can be scanned.

9.12 Barcode

UPC-A Barcode (No HRI)		ESC+BL	
HEX code	ESC <1B> ₁₆	BL <42> ₁₆ <4C> ₁₆	Parameter abbcccn~n
Initial value	None		

Validity and valid duration of command	When the power switch is off	The set parameter is not maintained.
	Validity in a job	The set parameter becomes invalid.
	Validity after a job	The set parameter becomes invalid.

[Function]

Adjusts the character barcode height of the first and the last digit to the same as that of guard bars.

[Format]

<BL>abbcccn~n

•Parameter

- a [Barcode symbology] = H : UPC-A ('H' fixed)
- b [Narrow bar width] = 01 to 12 dots
- c [Height of barcode] = 001 to 600 dots
- n [Print data] = Data : 11 digits fixed

[Example] Barcode symbology: UPC-A Narrow bar width: 03 Height of barcode: 120 Print data: 01234567890

<A>

<H>100<V>100<BL>H0312001234567890

<Q>2

<Z>

[Note]

1. This command supports UPC-A only. When setting [Barcode symbology] to the value other than 'H', command error will occur.
2. Settings for guard bars, HRI and ratio are as follows.

Guard bars	HRI	Ratio
Available	Not available	Fixed

3. Printer behavior when specifying the parameter outside the range is not supported.

9.13 Barcode

UPC-A barcode (HRI)		ESC+BL ~ ESC+d	
HEX code	ESC	BL~d	Parameter
	<1B> ₁₆	<42> ₁₆ <4C> ₁₆ -Font type	abbcccn~n~< d >n~n
Initial value	None		

Validity and valid duration of command	When the power switch is off	The set parameter is not maintained.
	Validity in a job	The set parameter becomes invalid.
	Validity after a job	The set parameter becomes invalid.

[Function]

Adjusts the character barcode height of the first and the last digits to the same as that of guard bars.

[Format 1]

<BL>abbcccn~n~<d>n~n

•Parameter

a	[Barcode symbology]	= H: UPC-A('H' fixed)
b	[Narrow bar width]	= 01 to 12 dots
c	[Height of barcode]	= 001 to 600 dots
n	[Print data]	= Data: 11 digits fixed
d	[Font type]	= X20 X21 X22 X23 X24 OA OB
n	[Print data]	= HRI data: 12 digits fixed

[Example] Barcode symbology: UPC-A Narrow bar width: 02, Height of barcode: 120
Print data: 01234567890 Font type: X21 HRI data: 01234567890

```
<A>
<H>100<V>100<BL>H0212001234567890
<X21>.01234567890
<Q>2
<Z>
```

[Note]

1. This command supports UPC-A only. When setting [Barcode symbology] to the value other than 'H', command error will occur.
2. For HRI, the following narrow bar widths are suitable.
12 dot/mm: Narrow bar width [03] and [04]
24 dot/mm: Narrow bar width [06], [07] and [08]
3. Use Modulus 10 to produce calculated value for a check digit, the 12th digit of HRI.
4. Settings for guard bars, HRI and ratio are as follows.

Guard bars	HRI	Ratio
Available	Available	Fixed

5. Printer behavior when specifying the parameter outside the range is not supported.

9.14 Barcode			
UPC-A Barcode (HRI)			ESC+BM
HEX code	ESC <1B> ₁₆	BM <42> ₁₆ <4D> ₁₆	Parameter abbcccn~n
Initial value	None		
Validity and valid duration of command	When the power switch is off	The set parameter is not maintained.	
	Validity in a job	The set parameter becomes invalid.	
	Validity after a job	The set parameter becomes invalid.	

[Function]

Adjusts the character barcode height of the first and the last digits to the same as that of guard bars.

[Format 1]

<BM>abbcccn~n

•Parameter

- a [Barcode symbology] = H: UPC-A('H' fixed)
- b [Narrow bar width] = 01 to 12 dots
- c [Height of barcode] = 001 to 600 dots
- n [Print data] = Data: 11 digits fixed

[Example] Barcode symbology: UPC-A Narrow bar width: 02 Height of barcode: 120 Print data:
20123948573

<A>
<H>100<V>100<BM>**H0212020123948573**
<Q>2
<Z>

[Note]

1. This command supports UPC-A only. When setting [Barcode symbology] to the value other than 'H', command error will occur.
2. For HRI, the following narrow bar widths are suitable.
12 dot/mm: Narrow bar width [03] and [04]
24 dot/mm: Narrow bar width [06], [07] and [08]
3. Settings for guard bar, HRI and ratio are as follows.

Guard bar	HRI	Ratio
Available	Available	Fixed

4. Printer behavior when specifying the parameter outside the range are not supported.

9.15 Barcode

POSTNET		ESC+BP	
HEX code	ESC <1B> ₁₆	BP <42> ₁₆ <50> ₁₆	Parameter n~n
Initial value	None		
Validity and valid duration of command	When the power switch is off	The set parameter is not maintained.	
	Validity in a job	The set parameter becomes invalid.	
	Validity after a job	The set parameter becomes invalid.	

[Function]

Specifies the POSTNET barcode.

[Format]

<BP>n~n

●Parameter

n

= Print data (See the POSTNET code table on the following page)

* Do not specify the number of digits other than listed below.

- 5 digits (Postnet-32 format)

- 6 digits (Postnet-37 format)

- 9 digits (Postnet-52 format)

- 11 digits (Postnet-62 Delivery Point format)

[Example] Postal code 11 digits : 01234567890

<A>

<V>100<H>200<BP>**01234567890**

<Q>2

<Z>

[Note]

1. Print data other than 5, 6, 9, and 11 digits are invalid.
2. Only numeric can be specified for print data.

POSTNET code table

					S				I				S				O					
b8					0	0	0	0	0	0	0	0	0	1	1	1	1	1	1	1	1	
b7					0	0	0	0	1	1	1	1	0	0	0	0	1	1	1	1	1	
b6					0	0	1	1	0	0	1	1	0	0	1	1	0	0	1	1	1	
b5					0	1	0	1	0	1	0	1	0	1	0	1	0	1	0	1	0	1
b4	b3	b2	b1		0	1	2	3	4	5	6	7	8	9	A	B	C	D	E	F		
0	0	0	0	0				0														
0	0	0	1	1				1														
0	0	1	0	2				2														
0	0	1	1	3				3														
0	1	0	0	4				4														
0	1	0	1	5				5														
0	1	1	0	6				6														
0	1	1	1	7				7														
1	0	0	0	8				8														
1	0	0	1	9				9														
1	0	1	0	A																		
1	0	1	1	B																		
1	1	0	0	C																		
1	1	0	1	D																		
1	1	1	0	E																		
1	1	1	1	F																		

10. 2D Code Commands

10.1 2D Code			
PDF417		ESC+2D10	
HEX code	ESC	2D10	Parameter
	<1B>16	<32>16<44>16<31>16<30>16	,aa,bb,c,dd,ee,(f)
Initial value	None		
Validity and valid duration of command	When the power switch is off	The— set parameter is not maintained.	
	Validity in a job	The set parameter becomes invalid.	
	Validity after a job	The set parameter becomes invalid.	

[Function]

Specifies PDF417 of 2D code.

[Format] Setting portion

<2D10>,aa,bb,c,dd,ee,(f)

• Parameter

a	[Minimum module width]	= 01 to 99 dots
b	[Minimum module height]	= 01 to 99 dots
c	[Security level]	= 0 to 8
d	[Number of data code words per digit] (cols)	= 01 to 30 00 : Automatic (Width depends on data number specified)
e	[Digit number per symbol] (rows)	= 03 to 90 00 : Automatic (Height depends on data number specified)
f	[Code type] (Omissible)	= 0 : Normal (When omitted) 1 : Truncated

[Format] Data portion

<DN>mmmm,n~n

• Parameter

m	[Data digit number]	= 1 to 2681 bytes
n	[Print data]	= Data

[Example 1] Minimum module width : 03 dots Minimum module height : 09 dots Security level : 3
Number of data code words per digit : 03 Digit number per symbol : 18

```
<A>
<V>100<H>200<2D10>.03.09.3.03.18
<DN>0010.0123456789
<Q>2
<Z>
```



[Example 2] Minimum module width : 03 dots Minimum module height : 09 dots Security level : 3
Number of data code words per digit : 03 Digit number per symbol : 18
Code type : Truncated

```
<A>
<V>100<H>200<2D10>.03.09.3.03.18.1
<DN>0010.0123456789
<Q>2
<Z>
```



[Note]

1. Use the Vertical Print Position <V> command and the Horizontal Print Position <H> command to set the print reference position for PDF417.

<V>100<H>200<2D10>*****

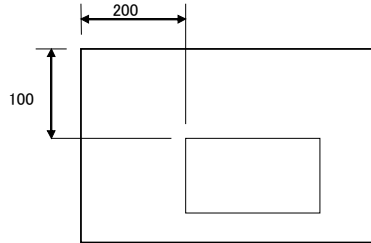

2. When d=e=00, the size of height to width (aspect ratio) will be at 1:2 based on the number of print data.
3. If the parameter ([d] and [e]) and the number of print data are not matching, print operation may not occur properly.
4. If increasing the security level, it is necessary to specify higher value for the parameter [d] or [e].
5. 01 and 02 dots are designable for module width; however, it may cause a reading problem.
6. As for the setting of [Minimum module height], be sure to specify 02 dots or higher in the head density of 12dot/mm, and 04 dots or higher in the head density of 24dot/mm.

[Tip]

1. Sequential number is disabled.
2. Print position cannot be designated by auto linefeed.
3. Designation of print for 00H ~ FFH is available.
4. Registration of format is available.
5. For higher print quality, increase the minimum module size.
6. For higher read rate, increase the security level.
7. Height of print may differ when printing the data consists of alphabet-only, numeric- only or alphanumeric.

PDF417 Code Table

					S				I				S				O												
					b8	0	0	0	0	0	0	0	0	0	1	1	1	1	1	1	1	1	1	1	1	1	1		
					b7	0	0	0	0	1	1	1	1	1	0	0	0	0	1	1	1	1	1	1	1	1	1		
					b6	0	0	1	1	0	0	1	1	1	0	0	1	1	0	0	1	1	0	0	1	1	1	1	
					b5	0	1	0	1	0	1	0	1	0	1	0	1	0	1	0	1	0	1	0	1	0	1	1	1
b4	b3	b2	b1		0	1	2	3	4	5	6	7	8	9	A	B	C	D	E	F									
0	0	0	0	0			SP	0	@	P	`	p																	
0	0	0	1	1			!	1	A	Q	a	q																	
0	0	1	0	2			"	2	B	R	b	r																	
0	0	1	1	3			#	3	C	S	c	s																	
0	1	0	0	4			\$	4	D	T	d	t																	
0	1	0	1	5			%	5	E	U	e	u																	
0	1	1	0	6			&	6	F	V	f	v																	
0	1	1	1	7			'	7	G	W	g	w																	
1	0	0	0	8			(8	H	X	h	x																	
1	0	0	1	9)	9	I	Y	i	y																	
1	0	1	0	A			*	:	J	Z	j	z																	
1	0	1	1	B			+	;	K	[k	{																	
1	1	0	0	C			,	<	L	¥	l																		
1	1	0	1	D			-	=	M]	m	}																	
1	1	1	0	E			.	>	N	^	n	~																	
1	1	1	1	F			/	?	O	_	o	DE L																	

PDF417 is settable within the range of 00H to FFH.

10.2 2D Code			
Micro PDF		ESC+2D12	
HEX code	ESC <1B> ₁₆	2D12 <32> ₁₆ <44> ₁₆ <31> ₁₆ <32> ₁₆	Parameter ,aa,bb,c,dd,(e)
Initial value	None		
Validity and valid duration of command	When the power switch is off		The set parameter is not maintained.
	Validity in a job		The set parameter becomes invalid.
	Validity after a job		The set parameter becomes invalid.

[Function]

Specifies MicroPDF of 2D code.

[Format] Setting portion

<2D12>,aa,bb,c,dd,(e)

●Parameter

a	[Minimum module width]	=	01 to 09 dots
b	[Minimum module height]	=	01 to 24 dots
c	[No. of data code words per line (cols)]	=	1 to 4
d	[No. of rows per symbol (rows)]	=	2 digits
e	[Binary mode] (Omissible)	=	0 : Standard *Becomes "0" when omitting. 1 : Binary mode

[Format] Data portion

<DN>mmm,n~n : When [Binary mode] is set to [1: Binary mode]
<DS>n~n : When [Binary mode] is set to [0: Standard]

●Parameter

m	[Data number]	=	0001 to 0366 bytes
n	[Print data]	=	Data

[Example]

Minimum module width: 02 dots Minimum module height: 04 dots
No. of data code words per line: 1 No. of rows per symbol: 14

<A>
<V>100<H>200<2D12>**02,04,1,14**
<DN>**0010,0123456789**
<Q>2
<Z>



[Note]

1. The number of rows per symbol is determined by the number of data code words per line. For details, refer to the next page [MicroPDF Symbol Size and Data Number].

* Symbol size of MicroPDF is as follows (Fixed 34 types).

[Micro PDF Symbol Size and Data Number]

Symbol size		Maximum data number		
Cols(c)	Rows(d)	Alphabet (A~Z) only	Numeric only	Binary mode
1	11	6	8	3
	14	12	17	7
	17	18	26	10
	20	22	32	13
	24	30	44	18
	28	38	55	22
2	8	14	20	8
	11	24	35	14
	14	36	52	21
	17	46	67	27
	20	56	82	33
	23	64	93	38
	26	72	105	43
3	6	10	14	6
	8	18	26	10
	10	26	38	15
	12	34	49	20
	15	46	67	27
	20	66	96	39
	26	90	132	54
	32	114	167	68
	38	138	202	82
	44	162	237	97
4	4	14	20	8
	6	22	32	13
	8	34	49	20
	10	46	67	27
	12	58	85	34
	15	76	111	45
	20	106	155	63
	26	142	208	85
	32	178	261	106
	38	214	313	128
	44	250	366	150

* When the data includes alphabet(Uppercase/Lowercase letters), numeric and control codes, the above values may differ depending on the number of characters to be combined.

MicroPDF code table

					S				I				S				O										
					b8	0	0	0	0	0	0	0	0	0	1	1	1	1	1	1	1	1	1	1	1	1	
					b7	0	0	0	0	1	1	1	1	1	0	0	0	0	1	1	1	1	1	1	1	1	
					b6	0	0	1	1	0	0	1	1	1	0	0	1	1	0	0	1	1	0	0	1	1	
					b5	0	1	0	1	0	1	0	1	0	1	0	1	0	1	0	1	0	1	0	1	0	1
b4	b3	b2	b1		0	1	2	3	4	5	6	7	8	9	A	B	C	D	E	F							
0	0	0	0	0			SP	0	@	P	`	p															
0	0	0	1	1			!	1	A	Q	a	q															
0	0	1	0	2			"	2	B	R	b	r															
0	0	1	1	3			#	3	C	S	c	s															
0	1	0	0	4			\$	4	D	T	d	t															
0	1	0	1	5			%	5	E	U	e	u															
0	1	1	0	6			&	6	F	V	f	v															
0	1	1	1	7			'	7	G	W	g	w															
1	0	0	0	8			(8	H	X	h	x															
1	0	0	1	9)	9	I	Y	i	y															
1	0	1	0	A			*	:	J	Z	j	z															
1	0	1	1	B			+	;	K	[k	{															
1	1	0	0	C			,	<	L	¥	l																
1	1	0	1	D			-	=	M]	m	}															
1	1	1	0	E			.	>	N	^	n	~															
1	1	1	1	F			/	?	O	_	o	DEL															

Micro PDF is settable within the range of 00H to FFH.

10.3 2D Code

MAXI Code		ESC+2D20	
HEX code	ESC <1B> ₁₆	2D20 <32> ₁₆ <44> ₁₆ <32> ₁₆ <30> ₁₆	Parameter ,a,(bbb,ccc,d~d)
Initial value	None		

Validity and valid duration of command	When the power switch is off	The set parameter is not maintained.
	Validity in a job	The set parameter becomes invalid.
	Validity after a job	The set parameter becomes invalid.

[Function]

Specifies Maxi code of 2D code.

[Format] Setting portion

<2D20>,a,(bbb,ccc,d~d)

● Parameter

- | | | | |
|---|-----------------|---|--|
| a | [Mode] | = | 2 : Delivery only (Numeric only) |
| | | | 3 : Delivery only (Alphanumeric only) |
| | | | 4 : Standard symbol |
| | | | 6 : Reader only |
| | | | * The following parameters are needed when setting [Mode] to "2" or "3". |
| | | | Omit the following parameters when setting [Mode] to "4" or "6". |
| b | [Service class] | = | 001 to 999 |
| c | [Country code] | = | 001 to 999 |
| d | [Postal code] | = | 0 to 999999999 (Mode 2) |
| | | | 000000 to 999999 (Mode 3) |
| | | | *In Mode 2, up to 9-digit (Numeric only) |
| | | | *In Mode 3, fixed 6-digit (English capital letter only) |

[Format] Data portion

<DN>mmmm,n~n

● Parameter

- | | | | |
|---|---------------|---|---------------------------|
| m | [Data number] | = | 0001 to 0138 |
| n | [Print data] | = | Data |
| | | | *00H cannot be specified. |

Mode	Service class	Country code	Postal code	Max. number of print data	
				Numeric	Alphanumeric
2	Fixed 3-digit (Numeric only)	Fixed 3-digit (Numeric only)	Up to 9-digit	123	84
3			Fixed 6-digit (Alphanumeric)		
4	Omission			138	93
6					

[Example]

Mode : Delivery only (Numeric only) Service class : 003
Country code : 081 Postal code : 123456789

<A>
<V>100<H>200<2D20>.2,003,081,123456789
<DN>0010,0123456789
<Q>2
<Z>

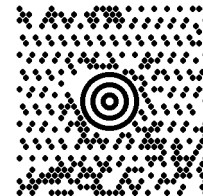

[Note]

1. Size of MAXI code printed by the number of data does not change.
2. When designating the parameter other than specified or when the number of print data is not matching, printing will not be performed.
3. Set Number of print data to 12 or higher when selecting Mode 4 or 6. If not, the printed MAXI code cannot be read with a scanner.

MAXI Code Table

				S				I				S				O						
				b8	0	0	0	0	0	0	0	0	0	1	1	1	1	1	1	1	1	1
				b7	0	0	0	0	1	1	1	1	0	0	0	0	1	1	1	1	1	1
				b6	0	0	1	1	0	0	1	1	0	0	1	1	0	0	1	1	1	1
				b5	0	1	0	1	0	1	0	1	0	1	0	1	0	1	0	1	0	1
b4	b3	b2	b1		0	1	2	3	4	5	6	7	8	9	A	B	C	D	E	F		
0	0	0	0	0			SP	0	@	P	`	p										
0	0	0	1	1			!	1	A	Q	a	q										
0	0	1	0	2			"	2	B	R	b	r										
0	0	1	1	3			#	3	C	S	c	s										
0	1	0	0	4			\$	4	D	T	d	t										
0	1	0	1	5			%	5	E	U	e	u										
0	1	1	0	6			&	6	F	V	f	v										
0	1	1	1	7			'	7	G	W	g	w										
1	0	0	0	8			(8	H	X	h	x										
1	0	0	1	9)	9	I	Y	i	y										
1	0	1	0	A			*	:	J	Z	j	z										
1	0	1	1	B			+	;	K	[k	{										
1	1	0	0	C			,	<	L	¥	l											
1	1	0	1	D			-	=	M]	m	}										
1	1	1	0	E			.	>	N	^	n	~										
1	1	1	1	F			/	?	O	_	o	DEL										

MAXI code is settable within the range of 01H to FFH.

10.4 2D Code

QR Code (Model 2)

ESC+2D30

HEX code	ESC <1B> ₁₆	2D30 <32> ₁₆ <44> ₁₆ <33> ₁₆ <30> ₁₆	Parameter ,a,bb,c,d,(ee,ff,gg)
Initial value	None		

Validity and valid duration of command	When the power switch is off	The set parameter is not maintained.
	Validity in a job	The set parameter becomes invalid.
	Validity after a job	The set parameter becomes invalid.

[Function]

Specifies QR code (Model 2) of 2D code.

[Format] Setting portion

<2D30>,a,bb,c,d,(ee,ff,gg)

● Parameter

- a [Error correction level] = L : 7%
M : 15%
Q : 25%
H : 30%
- b [Cell size] = 01 to 32 dots
* Specify 02 dots or higher in the head density of 12dot/mm, 04 dots or higher in the head density of 24dot/mm to be read by a scanner.
- c [Data setting mode] = 0 : Manual
1 : Automatic
*This setting affects the specification of print data.
- d [Concentration mode] = 0 : Normal mode
1 : Concentration mode

Specify the following parameters when setting [Concentration mode] to [1: Concentration mode].

In normal mode, omit the following parameters.

- e [Number of partitions by concentration mode] = 01 to 16
*This is to specify how many QR codes, partitioned by concentration mode, to connect.
- f [Sequential number partitioned by concentration mode] = 01 to 16
*This is to specify the number of QR code partitioned by concentration mode.
- g [Concentration mode parity data] = 00 to FF
*Carry out XOR logic operation of all the partitioned print data of QR code and then, specify this operation data in hexadecimal character. This is referred to as parity data.

[Format] Data portion

Manual setting (Data setting mode)

<DS>k,n~n * When setting [Input mode] to [Numeric mode], [Alphanumeric mode] and [Kanji mode].

<DN>mmmm,n~n * This will be used for binary specification.

Automatic setting (Data setting mode)

<DN>mmmm,n~n * [Input mode] can be automatically changed by the input data.

● Parameter

- k [Input mode] = 1 : Numeric mode
2 : Alphanumeric mode
3 : Kanji mode (Shift JIS Kanji code)
*This setting is needed only when setting [Data setting mode] to [0: Manual].
*Binary specification is available for this setting, but the data specification command is different.
- m [Data number] = 0001 to 2953
*This setting is needed when setting [Data setting mode] to [1: Automatic], or selecting Binary in manual setting.
- n [Print data] = Data

[Note 1]

1. If using Kanji in this specification, specify "number of Kanji characters x 2".
2. The data of [80H to 9FH] and [E0H to FFH] will be handled as Kanji mode. It cannot be specified as Binary.

[Example 1] Error correction level: 7% Cell size: 05
Data setting mode: Manual Concentration mode: Normal mode

<A>
<V>100<H>200<2D30>L,05,0,0
<DS>1,012345
<Q>2
<Z>



[Note 2]

1. When designating the parameter other than specified or when the number of print data is not matching, printing will not be performed.
2. For data portion, the data specification command may differ depending on the parameter settings or specified data contents.

[Example 2] Multiple data specification in manual setting (Data setting mode)

In manual setting, the data of input mode (numeric, alphanumeric, Kanji, Binary), specified in data portion, can be specified consecutively.

<A>
<V>100<H>200
<2D30>M,04,0,0
<DS>1,012345
<DS>2,ABC123
<DN>10,あいうえお
<Q>1
<Z>

[Note 3]

1. Parameter portion is followed by data portion. Data portion is followed by other data portion consecutively. If the data is not specified consecutively, printing may not be performed properly.
2. Keep the total data number(n) under 7,000 bytes. Data portion to be specified consecutively is up to 200.

QR Data Size (Model 2)

Version	Error Correction	Numeric	Alpha-numeric	Kanji	Binary	Version	Error Correction	Numeric	Alpha-numeric	Kanji	Binary		
1	L	41	25	10	17	1 1	L	772	468	198	321		
	M	34	20	8	14		M	604	366	155	251		
	2 1 × 2 1	Q	27	16	7		11	6 1 × 6 1	Q	427	259	109	177
	H	17	10	4	7		H	331	200	85	137		
2	L	77	47	20	32	1 2	L	883	535	226	367		
	M	63	38	16	26		M	691	419	177	287		
	2 5 × 2 5	Q	48	29	12		20	6 5 × 6 5	Q	489	296	125	203
	H	34	20	8	14		H	374	227	96	155		
3	L	127	77	32	53	1 3	L	1022	619	262	425		
	M	101	61	26	42		M	796	483	204	331		
	2 9 × 2 9	Q	77	47	20		32	6 9 × 6 9	Q	580	352	149	241
	H	58	35	15	24		H	427	259	109	177		
4	L	187	114	48	78	1 4	L	1101	667	282	458		
	M	149	90	38	62		M	871	528	223	362		
	3 3 × 3 3	Q	111	67	28		46	7 3 × 7 3	Q	621	376	159	258
	H	82	50	21	34		H	468	283	120	194		
5	L	255	154	65	106	1 5	L	1250	758	320	520		
	M	202	122	52	84		M	991	600	254	412		
	3 7 × 3 7	Q	144	87	37		60	7 7 × 7 7	Q	703	426	180	292
	H	106	64	27	44		H	530	321	136	220		
6	L	322	195	82	134	1 6	L	1408	854	361	586		
	M	255	154	65	106		M	1082	656	277	450		
	4 1 × 4 1	Q	178	108	45		74	8 1 × 8 1	Q	775	470	198	322
	H	139	84	36	58		H	602	365	154	250		
7	L	370	224	95	154	1 7	L	1548	938	397	644		
	M	293	178	75	122		M	1212	734	310	504		
	4 5 × 4 5	Q	207	125	53		86	8 5 × 8 5	Q	876	531	224	364
	H	154	93	39	64		H	674	408	173	280		
8	L	461	279	118	192	1 8	L	1725	1046	442	718		
	M	365	221	93	152		M	1346	816	345	560		
	4 9 × 4 9	Q	259	157	66		108	8 9 × 8 9	Q	948	574	243	394
	H	202	122	52	84		H	746	452	191	310		
9	L	552	335	141	230	1 9	L	1903	1153	488	792		
	M	432	262	111	180		M	1500	909	384	624		
	5 3 × 5 3	Q	312	189	80		130	9 3 × 9 3	Q	1063	644	272	442
	H	235	143	60	98		H	813	493	208	338		
10	L	652	395	167	271	2 0	L	2061	1249	528	858		
	M	513	311	131	213		M	1600	970	410	666		
	5 7 × 5 7	Q	364	221	93		151	9 7 × 9 7	Q	1159	702	297	482
	H	288	174	74	119		H	919	557	235	382		

Version	Error correction	Numeric	Alpha-numeric	Kanji	Binary	Version	Error correction	Numeric	Alpha-numeric	Kanji	Binary
2 1 101 × 101	L	2232	1352	572	929	3 1 141 × 141	L	4417	2677	1132	1840
	M	1708	1035	438	711		M	3486	2113	894	1452
	Q	1224	742	314	509		Q	2473	1499	634	1030
	H	969	587	248	403		H	1897	1150	486	790
2 2 105 × 105	L	2409	1460	618	1003	3 2 145 × 145	L	4686	2840	1201	1952
	M	1872	1134	480	779		M	3693	2238	947	1538
	Q	1358	823	348	565		Q	2670	1618	684	1112
	H	1056	640	270	439		H	2022	1226	518	842
2 3 109 × 109	L	2620	1588	672	1091	3 3 149 × 149	L	4965	3009	1273	2068
	M	2059	1248	528	857		M	3909	2369	1002	1628
	Q	1468	890	376	611		Q	2805	1700	719	1168
	H	1108	672	284	461		H	2157	1307	553	898
2 4 113 × 113	L	2812	1704	721	1171	3 4 153 × 153	L	5253	3183	1347	2188
	M	2188	1326	561	911		M	4134	2506	1060	1722
	Q	1588	963	407	661		Q	2949	1787	756	1228
	H	1228	744	315	511		H	2301	1394	590	958
2 5 117 × 117	L	3057	1853	784	1273	3 5 157 × 157	L	5529	3351	1417	2303
	M	2395	1451	614	997		M	4343	2632	1113	1809
	Q	1718	1041	440	715		Q	3081	1867	790	1283
	H	1286	779	330	535		H	2361	1431	605	983
2 6 121 × 121	L	3283	1990	842	1367	3 6 161 × 161	L	5836	3537	1496	2431
	M	2544	1542	652	1059		M	4588	2780	1176	1911
	Q	1804	1094	462	751		Q	3244	1966	832	1351
	H	1425	864	365	593		H	2524	1530	647	1051
2 7 125 × 125	L	3517	2132	902	1465	3 7 165 × 165	L	6153	3729	1577	2563
	M	2701	1637	692	1125		M	4775	2894	1224	1989
	Q	1933	1172	496	805		Q	3417	2071	876	1423
	H	1501	910	385	625		H	2625	1591	673	1093
2 8 129 × 129	L	3669	2223	940	1528	3 8 169 × 169	L	6479	3927	1661	2699
	M	2857	1732	732	1190		M	5039	3054	1292	2099
	Q	2085	1263	534	868		Q	3599	2181	923	1499
	H	1581	958	405	658		H	2735	1658	701	1139
2 9 133 × 133	L	3909	2369	1002	1628	3 9 173 × 173	L	6743	4087	1729	2809
	M	3035	1839	778	1264		M	5313	3220	1362	2213
	Q	2181	1322	559	908		Q	3791	2298	972	1579
	H	1677	1016	430	698		H	2927	1774	750	1219
3 0 137 × 137	L	4158	2520	1066	1732	4 0 177 × 177	L	7089	4296	1817	2953
	M	3289	1994	843	1370		M	5596	3391	1435	2331
	Q	2358	1429	604	982		Q	3993	2420	1024	1663
	H	1782	1080	457	742		H	3057	1852	784	1273

10.5 2D Code

QR Code (Model 1)		ESC+2D31	
HEX code	ESC	2D31	Parameter
	<1B> ₁₆	<32> ₁₆ <44> ₁₆ <33> ₁₆ <31> ₁₆	,a,bb,c,d(.ee,ff,gg)
Initial value	None		

Validity and valid duration of command	When the power switch is off	The set parameter is not maintained.
	Validity in a job	The set parameter becomes invalid.
	Validity after a job	The set parameter becomes invalid.

[Function]

Specifies QR code (Model 1) of 2D code.

[Format] Setting portion

<2D31>,a,bb,c,d(.ee,ff,gg)

• Parameter

- a [Error correction level] = L : 7%
M : 15%
Q : 25%
H : 30%
- b [Cell size] = 01 to 32 dots
* Specify 02 dots or higher in the head density of 12dot/mm, 04 dots or higher in the head density of 24dot/mm to be read by a scanner.
- c [Data setting mode] = 0 : Manual
1 : Automatic
*This setting affects the specification of print data.
- d [Concentration mode] = 0 : Normal mode
1 : Concentration mode

Specify the following parameters when setting [Concentration mode] to [1: Concentration mode].

In normal mode, omit the following parameters.

- e [Number of partitions by concentration mode] = 01 to 16
*This is to specify how many QR codes, partitioned by concentration mode, to connect.
- f [Sequential number partitioned by concentration mode] = 01 to 16
*This is to specify the number of QR code partitioned by concentration mode.
- g [Concentration mode parity data] = 00 to FF
*Carry out XOR logic operation of all the partitioned print data of QR code and then, specify this operation data in hexadecimal character. This is referred to as parity data.

[Format] Data portion

Manual setting (Data setting mode)

<DS>k,n~n * When setting [Input mode] to [Numeric mode], [Alphanumeric mode] and [Kanji mode].

<DN>m m m m,n~n * This will be used for binary specification.

Automatic setting (Data setting mode)

<DN>m m m m,n~n * [Input mode] can be automatically changed by the input data.

• Parameter

- k [Input mode] = 1 : Numeric mode
2 : Alphanumeric mode
3 : Kanji mode (Shift JIS Kanji code)
*This setting is needed only when setting [Data setting mode] to [0: Manual].
*Binary specification is available for this setting, but the data specification command is different.
- m [Data number] = 0001 to 0486
*This setting is needed when setting [Data setting mode] to [1: Automatic], or selecting Binary in manual setting.
- n [Print data] = Data

[Note 1]

1. If using Kanji in this specification, specify "number of Kanji characters x 2".
2. The data of [80H to 9FH] and [E0H to FFH] are handled as Kanji mode. They cannot be specified as binary.

[Example 1] Error correction level: 7% Cell size: 05
Data setting mode: Manual Concentration mode: Normal mode

<A>
<V>100<H>200
<2D31>.L.05.0.0
<DS>1.012345
<Q>2
<Z>



[Note 2]

1. When designating the parameter other than specified or when the number of print data is not matching, printing will not be performed.
2. For data portion, the data specification command may differ depending on the parameter settings or specified data contents.

[Example 2] Multiple data specification in manual setting (Data setting mode)

In manual setting, the data of input mode (numeric, alphanumeric, Kanji, binary), specified in data portion, can be specified consecutively.

<A>
<V>100<H>200
<2D31>.M.04.0.0
<DS>1.012345
<DS>2.ABC123
<DN>10.あいうえお
<Q>1
<Z>

[Note 3]

1. Parameter portion is followed by data portion. Data portion is followed by other data portion consecutively. If the data is not specified consecutively, printing may not be performed properly.
2. Keep the total data number(n) under 7,000 bytes. Data portion to be specified consecutively is up to 200.

QR Data Size (Model 1)

Version	Error Correction	Number	Alpha-numeric	Kanji	Binary
1	L	40	24	10	17
	M	33	20	8	14
21x21	Q	25	15	6	11
	H	16	10	4	7
2	L	81	49	20	34
	M	66	40	17	28
25x25	Q	52	31	13	22
	H	33	20	8	14
3	L	131	79	33	55
	M	100	60	25	42
29x29	Q	81	49	20	34
	H	52	31	13	22
4	L	186	113	48	78
	M	138	84	35	58
33x33	Q	114	69	29	48
	H	76	46	19	32
5	L	253	154	65	106
	M	191	116	49	80
37x37	Q	157	95	40	66
	H	105	63	27	44
6	L	321	194	82	134
	M	249	151	64	104
41x41	Q	201	122	51	84
	H	133	81	34	56
7	L	402	244	103	168
	M	311	188	80	130
45x45	Q	253	154	65	106
	H	167	101	43	70
8	L	493	299	126	206
	M	378	229	97	158
49x49	Q	301	183	77	126
	H	203	123	52	85
9	L	585	354	150	244
	M	441	267	113	184
53x53	Q	369	223	94	154
	H	239	145	61	100
10	L	690	418	177	287
	M	526	319	135	219
57x57	Q	433	262	111	180
	H	291	176	74	121

Version	Error Correction	Number	Alpha-numeric	Kanji	Binary
11	L	800	485	205	333
	M	608	368	156	253
61x61	Q	493	299	126	205
	H	342	207	87	142
12	L	915	555	234	381
	M	694	421	178	289
65x65	Q	579	351	148	241
	H	390	236	100	162
13	L	1030	624	264	429
	M	790	479	202	329
69x69	Q	656	398	168	273
	H	454	275	116	189
14	L	1167	707	299	486
	M	877	531	225	365
73x73	Q	738	447	189	307
	H	498	302	127	207

* This table is valid for manual setting only.

10.6 2D Code

Micro QR		ESC+2D32	
HEX code	ESC <1B> ₁₆	2D32 <32> ₁₆ <44> ₁₆ <33> ₁₆ <32> ₁₆	Parameter ,a,bb,c
Initial value	None		

Validity and valid duration of command	When the power switch is off	The set parameter is not maintained.
	Validity in a job	The set parameter becomes invalid.
	Validity after a job	The set parameter becomes invalid.

[Function]

Specifies Micro QR Code of 2D code.

[Format] Setting portion

<2D32>,a,bb,c

•Parameter

a [Error correction level] = L : 7%
M : 15%
Q : 25%

b [Cell size] = 01 to 32 dots

* Specify 02 dots or higher in the head density of 12dot/mm, 04 dots or higher in the head density of 24dot/mm to be read by a scanner.

c [Data setting mode] = 0 : Manual
1 : Automatic

[Format] Data portion

Manual setting (Data setting mode)

<DS>k,n~n * When setting [Input mode] to [Numeric mode], [Alphanumeric mode] and [Kanji mode].

<DN>m,mm,mm,n~n * This will be used for binary specification.

Automatic setting (Data setting mode)

<DN>m,mm,mm,n~n * [Input mode] can be automatically changed by the input data.

•Parameter

k [Input mode] = 1 : Numeric mode
2 : Alphanumeric mode
3 : Kanji mode (Shift JIS Kanji code)

*Binary specification is available for this setting, but the data specification command is different.

m [Data number] = 0001 to 0015
*This setting is needed when specifying binary.

n [Print data] = Data

[Note 1]

1. If using Kanji in the specification of <DN>, specify "number of Kanji characters x 2".
2. In the specification of <DN>, the data of [80H to 9FH] and [E0H to FFH] are handled as Kanji mode. They cannot be specified as binary.

[Example 1] Error correction level: 7%, Size of one side of cell: 04,

<A>
<V>100<H>200<2D32>,L,04
<DS>1,012345
<Q>2
<Z>



[Notes 2]

1. When designating the parameter other than specified or when the number of print data is not matching, printing will not be performed.
2. For data portion, the data specification command may differ depending on the parameter settings or specified data contents.

[Example 2] Multiple data specification in manual setting (Data setting mode)

The data of input mode (numeric, alphanumeric, Kanji, binary), specified in data portion, can be specified consecutively.

<A>
 <V>100<H>200
<2D30>.M.04.0.0
<DS>1.012345
<DS>2.ABC123
<DN>10.あいうえお
 <Q>1
 <Z>

[Note 3]

1. Parameter portion is followed by data portion. Data portion is followed by other data portion consecutively. If the data is not specified consecutively, printing may not be performed properly.

MicroQR Data Size

Version	Error correction	Numeric	Alphanumeric	Kanji	Binary
M1 (11×11)	L (error detection only)	5	—	—	—
M2 (13×13)	L	10	6	—	—
	M	8	5	—	—
M3 (15×15)	L	23	14	6	9
	M	18	11	4	7
M4 (17×17)	L	35	21	9	15
	M	30	18	8	13
	Q	21	13	5	9

QR Code (Numeric mode) table

					S				I				S				O								
					b8	0	0	0	0	0	0	0	0	1	1	1	1	1	1	1	1	1	1	1	1
					b7	0	0	0	0	1	1	1	1	0	0	0	0	1	1	1	1	1	1	1	1
					b6	0	0	1	1	0	0	1	1	0	0	1	1	0	0	1	1	0	0	1	1
					b5	0	1	0	1	0	1	0	1	0	1	0	1	0	1	0	1	0	1	0	1
b4	b3	b2	b1		0	1	2	3	4	5	6	7	8	9	A	B	C	D	E	F					
0	0	0	0	0				0																	
0	0	0	1	1				1																	
0	0	1	0	2				2																	
0	0	1	1	3				3																	
0	1	0	0	4				4																	
0	1	0	1	5				5																	
0	1	1	0	6				6																	
0	1	1	1	7				7																	
1	0	0	0	8				8																	
1	0	0	1	9				9																	
1	0	1	0	A																					
1	0	1	1	B																					
1	1	0	0	C																					
1	1	0	1	D																					
1	1	1	0	E																					
1	1	1	1	F																					

QR Code (Alphanumeric mode) table

					S				I				S				O					
b8					0	0	0	0	0	0	0	0	0	0	1	1	1	1	1	1	1	1
b7					0	0	0	0	1	1	1	1	0	0	0	0	1	1	1	1	1	1
b6					0	0	1	1	0	0	1	1	0	0	1	1	0	0	1	1	1	1
b5					0	1	0	1	0	1	0	1	0	1	0	1	0	1	0	1	0	1
b4	b3	b2	b1		0	1	2	3	4	5	6	7	8	9	A	B	C	D	E	F		
0	0	0	0	0			SP	0		P												
0	0	0	1	1				1	A	Q												
0	0	1	0	2				2	B	R												
0	0	1	1	3				3	C	S												
0	1	0	0	4			\$	4	D	T												
0	1	0	1	5			%	5	E	U												
0	1	1	0	6				6	F	V												
0	1	1	1	7				7	G	W												
1	0	0	0	8				8	H	X												
1	0	0	1	9				9	I	Y												
1	0	1	0	A			*	:	J	Z												
1	0	1	1	B			+		K													
1	1	0	0	C					L													
1	1	0	1	D			-		M													
1	1	1	0	E			.		N													
1	1	1	1	F			/		O													

QR Code (Binary mode) table

					S				I				S				O					
b8					0	0	0	0	0	0	0	0	0	0	1	1	1	1	1	1	1	1
b7					0	0	0	0	1	1	1	1	0	0	0	0	1	1	1	1	1	1
b6					0	0	1	1	0	0	1	1	0	0	1	1	0	0	1	1	1	1
b5					0	1	0	1	0	1	0	1	0	1	0	1	0	1	0	1	0	1
b4	b3	b2	b1		0	1	2	3	4	5	6	7	8	9	A	B	C	D	E	F		
0	0	0	0	0			SP	0	@	P	`	p										
0	0	0	1	1			!	1	A	Q	a	q										
0	0	1	0	2			"	2	B	R	b	r										
0	0	1	1	3			#	3	C	S	c	s										
0	1	0	0	4			\$	4	D	T	d	t										
0	1	0	1	5			%	5	E	U	e	u										
0	1	1	0	6			&	6	F	V	f	v										
0	1	1	1	7			'	7	G	W	g	w										
1	0	0	0	8			(8	H	X	h	x										
1	0	0	1	9)	9	I	Y	i	y										
1	0	1	0	A			*	:	J	Z	j	z										
1	0	1	1	B			+	;	K	[k	{										
1	1	0	0	C			,	<	L	¥	l											
1	1	0	1	D			-	=	M]	m	}										
1	1	1	0	E			.	>	N	^	n	-										
1	1	1	1	F			/	?	O	_	o	DEL										

QR Code (Binary mode) is settable within the range of [00H to 7FH] and [A0H to DFH].

QR Code Table (Kanji mode)

	ShiftJIS	0	1	2	3	4	5	6	7	8	9	A	B	C	D	E	F
Symbol	813F		SP	、	。	、	。	。	。	；	？	！	”	°	’	、	”
	814F	^	—	—	、	、	、	、	、	全	々	々	〇	—	—	-	/
	815F	／	～	∥		…	…	’	’	“	”	()	[]	[]
	816F	{	}	<	>	《	》	「	」	『	』	【	】	+	-	±	×
	8180	÷	=	≠	<	>	≧	≧	∞	∴	♂	♀	°	’	”	°C	¥
	8190	\$	¢	£	%	#	&	*	@	§	☆	★	◦	●	◎	◇	
	819E		◆	□	■	△	▲	▽	▼	※	〒	→	←	↑	↓	=	
Alphanumeric	824F	0	1	2	3	4	5	6	7	8	9						
	825F		A	B	C	D	E	F	G	H	I	J	K	L	M	N	O
	826F	P	Q	R	S	T	U	V	W	X	Y	Z					
	8280		a	b	c	d	e	f	g	h	i	j	k	l	m	n	o
	8290	p	q	r	s	t	u	v	w	x	y	z					
Hiragana	829E		あ	あ	い	い	う	う	え	え	お	お	か	が	き	ぎ	く
	82AE	ぐ	け	げ	こ	こ	さ	ざ	し	じ	す	ず	せ	が	そ	ぞ	た
	82BE	だ	ち	ぢ	っ	っ	づ	て	で	と	ど	な	に	が	ぬ	ね	は
	82CE	ば	ぱ	ひ	び	び	ふ	ぶ	ぶ	へ	べ	り	ほ	が	ぼ	ぼ	ま
	82DE	む	め	も	ゃ	ゃ	ゆ	ゆ	よ	よ	ら	り	る	が	ろ	ま	わ
	82EE	ゐ	ゑ	を	ん												
Katakana	833F		ア	ア	イ	イ	ウ	ウ	エ	エ	オ	オ	カ	ガ	キ	ギ	ク
	834F	グ	ケ	ゲ	コ	ゴ	サ	ザ	シ	ジ	ス	ズ	セ	ガ	ソ	ゾ	タ
	835F	ダ	チ	ヂ	ツ	ツ	ヅ	テ	デ	ト	ド	ナ	ニ	ガ	ネ	ノ	ハ
	836F	バ	パ	ヒ	ビ	ピ	フ	ブ	プ	ヘ	ベ	リ	ホ	ガ	ポ	マ	ミ
	8380	ム	メ	モ	ヤ	ヤ	ユ	ユ	ヨ	ヨ	ラ	リ	ル	ガ	ロ	ワ	ワ
	8390	キ	エ	ヲ	ン	ヴ	カ	ケ									
Greek	839E		A	B	Γ	Δ	E	Z	H	Θ	I	K	Λ	M	N	Ξ	O
	83AE	Π	P	Σ	T	Υ	Φ	X	Ψ	Ω	ι	κ	λ	μ	ν	ξ	ο
	83BE		α	β	Υ	δ	ε	ζ	η	θ	ι	κ	λ	μ	ν	ξ	ο
	83CE	π	ρ	σ	τ	υ	φ	χ	ψ	ω							
Russian	843F		A	B	B	Г	Д	E	E	Ж	З	И	И	К	Л	М	Н
	844F	О	П	Р	С	Т	У	Ф	Х	Ц	Ч	Ш	Щ	Ъ	Ы	Ь	Э
	845F	Ю	Я														
	846F		а	б	в	г	д	е	ё	ж	з	и	й	к	л	м	н
	8480	о	п	р	с	т	у	ф	х	ц	ч	ш	щ	ъ	ы	ь	э
	8490	ю	я														

	ShiftJIS	0	1	2	3	4	5	6	7	8	9	A	B	C	D	E	F
ア	889E 88AE 88BE	垂 旭	葦 葺	啞 芦 安	娃 鯪 庵	阿 梓 按	哀 庄 暗	愛 幹 案	挨 扱 間	始 宛 鞍	逢 姐 杏	葵 虻	茜 飴	穉 絢	惡 綾	握 鮎	渥 或
イ	88BE 88CE 88DE 88EE 893F	夷 萎 稻	委 衣 茨 院	威 謂 芋 陰	尉 違 鱗 隱	惟 遺 允 韻	意 医 印 吋	慰 井 咽	易 亥 員	椅 域 因	為 育 姻	以 畏 郁 引	伊 異 磯 飲	位 移 一 淫	依 維 壹 胤	偉 緯 溢 蔭	困 胃 逸
ウ	893F 894F 895F	碓 雲	臼	渦	嘘	唄	鬱	右 蔚	宇 鰻	烏 姥	羽 廐	迂 浦	雨 瓜	卯 閏	鶉 嚙	窺 云	丑 運
エ	895F 896F 8980 8990	穎 園 艷	荏 英 堰 苑	餌 衛 奄 菌	叡 詠 宴 遠	營 銳 延 鉛	嬰 液 怨 鴛	影 疫 掩 塩	映 益 援	曳 馱 沿	榮 悅 演	永 謁 炎	泳 越 焰	洩 閱 煙	瑛 榎 燕	盈 厭 猿	穎 円 縁
オ	8990 899E 89AE	屋	押 憶	旺 臆	橫 桶	欧 牡	毆 乙	王 俺	於 翁 卸	汚 襖 恩	甥 鶯 温	凹 鷗 穩	央 黃 音	奧 岡	往 沖	忝 荻	億
カ	89AE 89BE 89CE 89DE 89EE 8A3F 8A4F 8A5F 8A6F 8A80 8A90 8A9E 8AAE 8ABE 8ACE 8ADE	伽 火 迦 介 外 垣 覚 檀 叶 完 汗 莞 巖	伽 珂 過 会 魁 咳 柿 角 梶 梶 粥 官 漢 觀 玩	佳 禍 霞 解 晦 害 蚌 赫 鱖 樺 刈 寬 澗 諫 癌	加 禾 蚊 回 械 崖 鈎 較 澗 靴 苺 干 淮 貫 眼	可 稼 俄 塊 海 慨 劃 郭 割 株 瓦 幹 環 還 岩	嘉 箇 峨 壞 灰 概 嚇 閣 喝 兜 乾 患 甘 鑑 翫	夏 花 我 迴 界 涯 各 隔 恰 竈 侃 感 監 間 賈	嫁 苛 牙 快 皆 碍 廓 革 括 蒲 冠 憤 看 閑 雁	家 茄 画 怪 絵 蓋 拈 学 活 釜 寒 憾 竿 関 頑	寡 荷 臥 悔 芥 街 攪 岳 渴 鎌 刊 換 管 陷 顔	科 華 芽 恢 蟹 該 格 樂 滑 嚙 勘 敢 簡 韓 願	暇 菓 蛾 懷 開 鎧 核 額 葛 鴨 勸 柑 緩 館	下 果 蝦 賀 戒 階 骸 殼 顎 褐 栢 卷 桓 缶 館	化 架 課 雅 拐 貝 湮 獲 掛 轄 茅 喚 棺 翰 丸	仮 歌 嘩 餓 改 凱 馨 確 笠 且 萱 堪 款 肝 含	何 河 貨 駕 効 蛙 穫 桴 鯉 姦 歛 艦 岸

	ShiftJIS	0	1	2	3	4	5	6	7	8	9	A	B	C	D	E	F
キ	8ADE												企	伎	危	喜	器
	8AEE	基	奇	嬉	寄	岐	希	幾	忌	揮	机	旗	企	伎	危	喜	器
	8B3F		機	婦	毅	氣	汽	畿	祈	季	稀	紀	既	期	棋	棄	起
	8B4F	軌	輝	歸	騎	鬼	龜	偽	儀	妓	宜	戲	徽	規	記	貴	疑
	8B5F	祇	義	飢	誼	議	掬	菊	鞠	吉	吃	喫	技	擬	欺	犧	杵
	8B6F	黍	却	客	脚	虐	逆	丘	久	仇	休	及	桔	橋	詰	砧	救
	8B80	朽	求	汲	泣	灸	球	究	窮	笈	級	糾	給	宮	弓	急	居
	8B90	巨	拒	拋	拳	渠	虛	許	距	鋸	漁	禦	魚	旧	牛	去	居
	8B9E		供	俠	僑	兇	競	共	凶	協	匡	狹	叫	亨	境	興	強
	8BAE	彊	怯	恐	恭	挾	教	橋	況	狂	狹	矯	胸	喬	峽	蕎	鄉
	8BBE	鏡	響	饗	驚	仰	凝	堯	曉	業	局	曲	極	玉	桐	糝	僅
8BCE	勤	均	巾	錦	斤	欣		琴	禁	禽	筋	緊	芹	菌	矜	襟	
8BDE	謹	近	金	吟	銀												
ク	8BDE						九	俱	句	区	狗	玖	矩	苦	軀	驅	駮
	8BEE	駒	具	愚	虞	喰	空	偶	寓	遇	隅	串	櫛	釧	屑	屈	君
	8C3F		掘	窟	沓	靴	轡	窪	熊	限	彖	栗	縹	桑	歛	勲	
	8C4F	薰	訓	群	軍	郡											
ケ	8C4F						卦	袈	祁	係	傾	刑	兄	啓	圭	珪	型
	8C5F	契	形	徑	惠	慶	慧	憩	揭	携	敬	景	桂	溪	畦	稽	系
	8C6F	經	繼	繫	野	荃	荊	蚩	計	詣	警	輕	頸	鷄	芸	迎	鯨
	8C80	劇	戟	擊	激	隙	析	傑	欠	詣	潔	穴	結	血	訣	月	鯨
	8C90	儉	倦	健	兼	券	劍	喧	圈	決	嫌	建	憲	懸	拳	捲	鯨
	8C9E		檢	榘	牽	券	劍	喧	圈	堅	嫌	建	肩	見	拳	捲	鯨
	8CAE	鍵	險	榘	牽	犬	獻	元	硯	絹	臬	減	源	謙	賢	軒	鯨
	8CBE	言	諺	限	駮	齧	元		敵	幻	弦			玄	現	絃	駮
コ	8CBE				乎	個	古	呼	固	姑	孤	己	庫	弧	戸	故	枯
	8CCE	湖	狐	糊	袴	股	胡	菰	虎	誇	跨	鈷	雇	顧	鼓	互	
	8CDE	伍	午	吳	吾	娛	後	御	悟	梧	檣	瑚	碁	語	誤	翻	
	8DEE	乞	鯉	交	佞	侯	候	倖	光	公	功	効	碁	厚	口	康	
	8D3F		后	交	佞	垢	好	孔	孝	宏	工	巧	勾	幸	庾	洪	
	8D4F	弘	恒	喉	坑	垢	控	攻	昂	晃	更	杭	巷	梗	江	肱	
	8D5F	浩	港	溝	抗	垢	硬	稿	糠	晃	紘	絞	校	梗	肯	降	
	8D6F	腔	膏	航	甲	皇	衡	講	貢	紅	紅	絞	綱	梗	閤	刻	
	8D80	項	香	高	鴻	剛	劫	号	合	壕	拷	濠	豪	轟	克	刻	

	ShiftJIS	0	1	2	3	4	5	6	7	8	9	A	B	C	D	E	F
コ	8D90 8D9E 8DAE	告 紺	国 此 良	穀 頃 魂	酷 今	鵠 困	黒 坤	獄 壘	漉 婚	腰 恨	飭 懇	忽 昏	惚 昆	骨 根	狛 梱	込 混	痕
サ	8DAE 8DBE 8DCE 8DDE 8DEE 8E3F 8E4F 8E5F	娑 歳 材 咋 三 酸	坐 济 罪 榨 察 傘 餐	座 災 財 昨 拶 参 斬	些 挫 采 冚 朔 撮 山 暫	佐 債 犀 坂 柵 擦 惨 残	又 催 碎 阪 窄 札 撒	峻 再 砦 堺 策 殺 散	嵯 最 祭 神 索 薩 棧	左 哉 齋 肴 錯 雜 燦	差 塞 細 咲 桜 阜 珊	查 妻 菜 崎 鮭 鯖 産	沙 宰 裁 埼 笹 捌 算	瑳 彩 載 碕 匙 鑄 纂	砂 才 際 鷺 冊 鮫 蚕	詐 採 剂 作 刷 皿 讚	鎖 裁 在 削 晒 贊
シ	8E5F 8E6F 8E80 8E90 8E9E 8EAE 8EBE 8ECE 8EDE 8EEE 8F3F 8F4F 8F5F 8F6F 8F80 8F90 8F9E 8FAE 8FBE 8FCE 8FDE 8FEE 903F	姉 死 諮 式 疾 斜 酌 腫 衆 柔 出 準 署 尚 樟 笑 鉦 情	姿 氏 資 次 識 質 煮 釈 趣 宗 襲 汁 術 潤 書 勝 庄 樵 粧 鍾 擾 拭	子 獅 賜 滋 鳴 実 社 錫 酒 就 讐 洪 述 盾 薯 匠 床 沼 紹 鐘 条 植	屍 祉 雌 治 竺 蔀 紗 若 首 州 蹴 獸 俊 純 諸 升 廠 消 肖 障 杖 殖	市 私 飼 爾 軸 篠 者 寂 儒 修 輯 縱 峻 巡 諸 召 彰 涉 菖 鞞 淨 燭	仕 師 糸 齒 事 瘳 零 柴 車 惹 呪 拾 曾 銃 瞬 醇 叙 商 抄 燒 蕉 丈 暈 織	仔 志 紙 事 痔 霏 柴 車 惹 呪 拾 曾 銃 瞬 醇 叙 商 抄 燒 蕉 丈 暈 織	伺 思 紫 似 磁 七 芝 遮 主 寿 洲 酬 叔 竣 順 女 唱 招 焦 衝 丞 穰 色	使 指 肢 侍 示 叱 屢 蛇 取 授 秀 集 夙 舜 処 序 嘗 掌 照 裳 乘 蒸 触	刺 支 脂 兒 而 執 蕊 邪 守 樹 秋 醜 宿 駿 初 徐 獎 捷 症 訟 冗 讓 食	司 孜 至 字 耳 失 縞 借 手 綬 終 什 淑 准 所 恕 妾 昇 省 証 剩 釀 蝕	史 斯 視 寺 自 嫉 舍 勺 朱 需 繡 住 祝 循 暑 鋤 娼 昌 硝 詔 城 錠 辱	嗣 施 詞 慈 蒔 室 写 尺 殊 囚 習 充 縮 旬 曙 除 宵 昭 礁 詳 場 囑 尻	四 旨 詩 持 辞 悉 射 杓 狩 收 臭 十 肅 楯 渚 傷 將 晶 祥 象 壤 埴 伸	士 枝 試 時 夕 湿 捨 灼 珠 周 舟 從 塾 殉 庶 償 小 松 称 賞 壤 飾 信	始 止 誌 鹿 漆 赦 爵 種 蒐 戎 熟 淳 緒 少 梢 章 醬 常 侵

	ShiftJIS	0	1	2	3	4	5	6	7	8	9	A	B	C	D	E	F
シ	904F	唇	娠	寢	審	心	慎	振	新	晋	森	榛	浸	深	申	疹	真
	905F	神	秦	紳	臣	芯	薪	親	診	身	辛	進	針	震	人	仁	刃
	906F	塵	壬	尋	甚	尽	腎	訊	迅	陣	韌						
ス	906F																
	9080	逗	吹	垂	帥	推	水	炊	睡	粹	翠	筈	諏	須	酢	凶	厨
	9090	瑞	髓	崇	嵩	数	枢	趨	雛	据	杉	袁	菅	醉	錐	錘	随
	909E		澄	摺	寸									頗	雀	裾	
セ	909E					世	瀨	畝	是	凄	制	勢	姓	征	性	成	政
	90AE	整	星	晴	棲	栖	正	清	性	生	盛	精	聖	声	製	西	誠
	90BE	誓	請	逝	醒	青	静	齐	税	脆	隻	席	惜	戚	斥	昔	析
	90CE	石	積	籍	績	脊	責	赤	跡	蹟	碩	切	拙	接	撰	折	設
	90DE	窃	節	説	雪	絶	舌	蝉	仙	蹟	千	占	宣	専	尖	川	戰
	90EE	扇	撰	栓	梅	泉	浅	洗	染	先	煎	煽	旋	穿	箭	線	閃
	913F		織	羨	腺	舛	船	薦	詮	潜	踐	選	遷	穿	箭	閃	鮮
914F	前	善	漸	然	全	禅	繕	膳	糶								
ソ	914F																
	915F	狙	疏	疎	礎	祖	租	粗	素	組	噌	塑	咀	措	曾	曾	楚
	916F	双	叢	倉	喪	壯	奏	爽	宋	層	蘇	訴	阻	迦	鼠	僧	創
	9180	操	早	曹	巢	槍	槽	漕	燥	争	匠	惣	想	搜	掃	挿	搔
	9190	草	莊	葬	蒼	藻	装	走	送	遭	瘦	相	窓	糴	総	綜	聰
	919E		臆	蔵	贈	造	促	側	則	即	鎗	霜	騷	像	増	憎	俗
91AE	属	賊	族	統	卒	袖	其	揃	存	息	捉	束	測	足	速		
タ	91AE																
	91BE	太	汰	詫	唾	墮	妥	惰	打	柁	舵	橈	陀	馱	驂	他	多
	91CE	对	耐	岱	帶	待	怠	態	戴	替	泰	滯	胎	腿	苔	体	堆
	91DE	退	速	隊	黛	鯛	代	台	大	第	醒	題	鷹	滝	瀧	袋	貸
	91EE	宅	托	扱	拓	沢	濯	琢	託	鐸	濁	諾	茸	胤	卓	只	啄
	923F		叩	但	達	辰	奪	脱	異	豎	泔	棚	苧	狸	樽	誰	耽
	924F	丹	单	嘆	坦	担	探	旦	歎	淡	汕	炭	谷	端	綻		
925F	胆	蛋	誕	鍛	団	壇	彈	断	暖	湛	檀	短	端	綻			
チ	925F																
	926F	弛	恥	智	池	痴	稚	置	致	蚰	遲	馳	築	畜	竹	知	地
	9280	逐	秩	窒	茶	嫡	着	中	仲	宙	忠	抽	昼	柱	注	筑	蓄
	9290	註	酎	鑄	駐	糶	瀦	猪	苧	著	貯	丁	兆	涸	喋	虫	衷

	ShiftJIS	0	1	2	3	4	5	6	7	8	9	A	B	C	D	E	F
チ	929E 92AE 92BE	帖 聽 沈	帳 脹 珍	庀 蝶 賃	帛 調 陳	張 謀 陳	彫 超	徵 跳	懲 鈔	挑 長	暢 頂	朝 鳥	潮 勅	牒 抄	町 直	眺 朕	
ツ	92BE 92CE 92DE	槻 釣	佃 鶴	漬 柘	辻	津 蔦	墜 綴	椎 鏑	槌 椿	迫 潰	鎚 坪	痛 壺	通 孀	塚 紬	柁 爪	捆 吊	
テ	92DE 92EE 933F 934F 935F	悌 徹 点	抵 邸 撤 伝	亭 挺 鄭 轍 殿	低 提 釘 迭 澱	停 梯 鼎 鉄 田	偵 汀 泥 典 電	剃 砒 摘 填	貞 禎 擢 天	呈 程 敵 展	堤 締 滴 店	定 艇 的 添	帝 訂 笛 纏	底 諦 適 甜	庭 蹄 鎬 貼	廷 逋 溺 轉	弟 哲 顛
ト	935F 936F 9380 9390 939E 93AE 93BE 93CE	登 凍 盜 動 得 鳶	菟 刀 淘 董 同 德 苦	賭 唐 湯 蕩 堂 澆 寅	途 塔 濤 藤 導 特 西	都 塘 灯 討 懂 督 瀨	兔 砥 岩 当 痘 豆 洞 篤 屯 噸	吐 砾 島 痘 踏 瞳 毒 惇	堵 努 嶋 禱 逃 童 独 敦	塗 度 悼 等 透 胴 読 沌	妬 土 投 答 鏡 苟 析 豚	屠 奴 搭 筒 陶 道 橡 遁	徒 怒 東 糖 頭 銅 凸 頓	斗 倒 桃 統 騰 峠 突 吞	杜 党 禱 到 鬪 鴉 椀 曇 南	渡 冬 棟 働 匿 届 鈍	
ナ	93DE 93EE	奈 軟	那 難	内 汝	乍	凧	薙	謎	灘	捺	鍋	檜	馴	繩	罨	南	楠
ニ	93EE 943F		如 尿	二 菲		尼 任	弑 妊	迹 忍	匂 認	賑	肉	虹	廿	日	乳	入	
ヌ	943F									濡							
ネ	943F 944F	念	捻	燃	燃	粘					禰	祢	寧	葱	猫	熱	年
ノ	944F 945F	農	視	蚤			乃	迺	之	埜	囊	惱	濃	納	能	腦	膿
ハ	945F 946F 9480 9490 949E 94AE	俳 楳 柏 醜	廢 煤 泊 函 髮	拝 狼 白 箱 伐	巴 排 買 箔 裕 罰	把 敗 売 粕 箸 拔	播 杯 賠 船 肇 箬 筏	霸 盃 陪 薄 筭 罽 閥	杷 牌 這 迫 櫨 鳩	波 背 蠅 曝 幡 嘶	派 肺 秤 漠 肌 塙	琶 輩 矧 爆 焮 焜 隼	破 配 菽 縛 畠 隼	婆 倍 伯 莫 八 伴	罵 培 剥 駁 鉢 判	芭 媒 博 麥 澆 澆 半	馬 梅 拍 癸 反

	ShiftJIS	0	1	2	3	4	5	6	7	8	9	A	B	C	D	E	F	
ハ	94BE 94CE	叛采	帆煩	搬頒	斑飯	板挽	汎晩	汎番	版盤	犯磐	班蕃	畔蛮	繁	般	藩	販	範	
ヒ	94CE 94DE 94EE 953F 954F 955F 956F	彼誹	悲費 鼻	扉避 柎	批非 稗	披飛 匹	斐樋 疋	比簸 髭	泌備 彦	疲尾 膝	皮微 菱	碑枇 肘	匪秘 毘	卑緋 毚	否罷 眉	妃肥 美筆	庇被 逼	豹貧
フ	956F 9580 9590 959E 95AE	斧武 憤	普舞 福扮	浮葡 腹焚	父蕪 複奮	不符 部覆	付腐 封淵	埠膚 楓弗	夫芙 風弘	婦譜 葦沸	富負 蒞仏	富賦 伏物	布赴 副鮒	府阜 復分	怖附 幅吻	扶侮 服噴	敷撫 墳	
ヘ	95AE 95BE 95CE	弊偏	柄變	並片	蔽篇	閉編	陛辺	米返	頁遍	僻便	壁勉	丙癖 婉	併碧 弁	兵別 鞭	塀警	幣蔑	平篋	
ホ	95CE 95DE 95EE 963F 964F 965F 966F	圃俸 飽棒 撲	捕包 法鳳 冒朴	步呆 泡鵬 紡牧	甫報 烹乏 肪睦	補奉 砲亡 膨穆	輔寶 縫傍 謀卸	穗峰 胞剖 貌勃	募峯 芳坊 貿沒	墓崩 萌妨 銚殆	慕庖 蓬帽 防堀	戊抱 蜂忘 吠幌	暮捧 褒忙 類奔	母放 訪房 北本	保簿 方豐 暴僕	舖菩 朋邦 望卜	舖做 鋒某 墨盆	
マ	9680 9690 969E	摩鱒	磨榭 漫	魔亦 蔓	麻俣	埋又	妹抹	味末	枚沫	每迄	哩俛	楨繭	幕磨	膜万	枕慢	鮪滿	枉	
ミ	969E 96AE	耗	民	眠	味	未	魅	巳	箕	岬	密	蜜	湊	蓑	稔	脈	妙	
ム	96AE				務	夢	無	牟	矛	霧	鷓	棕	婿	娘				
メ	96AE 96BE	明	盟	迷	銘	鳴	姪	牝	滅	免	棉	綿	緬	面	冥	名	命	
モ	96BE 96CE	茂	妄	孟	毛	猛	盲	網	耗	蒙	儲	木	默	目	空	摸	模餅	

	ShiftJIS	0	1	2	3	4	5	6	7	8	9	A	B	C	D	E	F
モ	96DE	尤	戾	粃	貰	問	悶	紋	門	匆							
ヤ	96DE 96EE	矢	厄	役	約	葉	訳	躍	靖	柳	也	冶	夜	爺	耶	野	弥
ユ	96EE 973F 974F	涌	諭	輸	唯	佑	優	勇	友	宥	幽	悠	愉	愈	油	癒	湧
ヨ	974F 975F 976F 9780	誉	輿	預	傭	幼	妖	容	庸	揚	揺	擁	曜	楊	予	余	与
ラ	9780 9790	乱	卵	嵐	欄	濫	羅	螺	裸	来	莱	頼	雷	洛	絡	落	酪
リ	9790 979E 97AE 97BE 97CE	琉	痢	裏	裡	里	離	陸	律	利率	吏	履	李	梨	理	璃	溜
ル	97CE 97DE	類												瑠	罌	淚	累
レ	97DE 97EE 983F	齡	令	伶	例	冷	勵	嶺	怜	玲	礼	苓	鈴	隸	零	靈	麗
ロ	983F 984F 985F	樓	榔	浪	漏	呂	魯	櫓	炉	賂	路	露	勞	婁	廊	弄	朗
ワ	985F 986F	椀	倭	和	話	歪	賄	脇	惑	梓	鷺	互	亘	鰐	詫	藁	蕨

	ShiftJIS	0	1	2	3	4	5	6	7	8	9	A	B	C	D	E	F
一	989E		弋	丐	丕												
丨	989E					个	卩										
丶	989E							丶	井								
丿	989E									丿	乂	乖	乘				
乙	989E													亂			
丿	989E 98AE	舒													丿	豫	事
二	98AE		式	于	亞	亟											
一	98AE					一	亢	京		毫	亶						
人	98AE 98BE 98CE 98DE 98EE 993F 994F	仞 佩 俸 偃 監	仞 佰 倚 假 僉 儕	仞 侑 倨 會 僂 儔	价 佯 偃 借 傳 儂	伉 來 倪 修 儂 儂	侏 侑 倨 倨 儂 儂	佛 倪 倨 倨 倨 儂	佻 俚 俚 倨 儂 儂	佻 俚 俚 倨 儂 儂	从 佻 倨 倨 儂 儂	仍 佻 倨 倨 儂 儂	仄 佻 倨 倨 儂 儂	仆 侏 俚 倨 儂 儂	仞 侏 俚 倨 儂 儂	仗 佻 俚 倨 儂 儂	仗 佻 俚 倨 儂 儂
儿	994F									儿	兀	兒		兌	兔	兢	競
入	995F	兩	兪														
八	995F			兮	冀												
冂	995F					冂	回	册	冉	冂	冂	冂	冕				
冂	995F 996F	寫	冂											冂	冕	冂	冂
丷	996F			丷	决	冂	冲	冰	况	冽	涸	凉	凜				
几	996F 9980													几	處	凵	凭
凵	9980		凵	凵													
刀	9980 9990 999E				刃	刊	刂	刂	刂	刪	刮	刮	剝	剝	剝	剝	剝
			剝	剔	剪	剝	剩	剝	剝	劍	劍	劍	劍	剝	剝	剝	剝
				辦													
力	999E 99AE			勑	劭	劭	劭	劭	劭	勑	勞	勑	勑	勑	勑	勑	勑
勑	99AE	勑															
勑	99AE		勑	勑	勑	勑	勑	勑	勑								
七	99AE									七							
匚	99AE										匚	匚	匚	匚	匚	匚	匚

	ShiftJIS	0	1	2	3	4	5	6	7	8	9	A	B	C	D	E	F	
匸	99AE																匸 區	
十	99BE	𠂇	卅	卅	卉	卂	準											
卜	99BE							卞										
冂	99BE							冂		厄	𠂇	卻	卷					
厂	99BE 99CE													厂	厖	厠	厦	
厶	99CE				厶	參	篡											
又	99CE							雙	叟	曼	變							
口	99CE 99DE 99EE 9A3F 9A4F 9A5F 9A6F 9A80 9A90	呀 咒 嗽 啣 噤	听 呻 咫 唾 嗔 噤	吭 咀 晒 啣 嘔 噤	吼 嗽 咤 啣 嘔 噤	吮 咄 咄 售 噴 噪	呐 咐 高 啜 單 喉 噤	吩 咆 啞 啞 啞 啞 啞	吝 哇 哥 啞 啞 啞 啞	呖 咏 呖 哦 啞 啞 啞	咏 咸 唏 唸 唸 噤 噤	叮 呵 啞 咬 啞 啞 啞 啞	叨 咎 咬 啞 啞 啞 啞 啞	叭 咳 哄 哮 喙 嗅 嚮	叭 呱 哈 哭 喀 嗟 嚮	吁 呷 咨 啞 喀 嗟 嚮	咩 咩 咩 咩 咩 咩 咩 咩	
口	9A90 9A9E		圈	國	圍	圓	團	圖	喬	口	囧	囧	囧	囧	囧	囧	囧	
土	9A9E 9AAE 9ABE 9ACE 9ADE	坩 埤 墅 壘	垂 聖 壘 壤	垚 垚 墟 壘	坡 埠 埠 壘	坩 坩 壘 壘	垚 垚 壘 壘	垚 垚 壘 壘	垚 垚 壘 壘	坩 坩 壘 壘	坩 坩 壘 壘	坩 坩 壘 壘	坩 坩 壘 壘	坩 坩 壘 壘	坩 坩 壘 壘	坩 坩 壘 壘	坩 坩 壘 壘	坩 坩 壘 壘
士	9ADE				壯	壺	壹	壻	壺	壽								
夕	9ADE									夕								
夕	9ADE										夕	復						
夕	9ADE													夕	夢	夥		
大	9ADE 9AEE	夭	本	夸	夾	奇	奕	奂	奎	奚	奘	奢	奠	奧	獎	奩	夫	
女	9B3F 9B4F 9B5F 9B6F	娑 媽 孃	奸 娜 媽 孃	妁 娉 媼 孃	妝 娉 媼 孃	佞 媼 嫩	佞 媼 孃	妣 媼 孃	妣 媼 孃	姆 娶 嬌	媼 婢 嬋	姜 婪 嬋	妍 媚 嬋	姘 媼 嫩	姚 媼 孃	娥 媼 孃	娟 媼 孃	

	ShiftJIS	0	1	2	3	4	5	6	7	8	9	A	B	C	D	E	F
子	9B6F				子	孕	孚	幸	孛	孩	孰	孳	孳	學	孳	孺	
宀	9B6F 9B80 9B90	它 寶	宦	宸	寃	寇	崔	寔	寐	寤	實	寢	寔	寥	寫	寰	寶
寸	9B90		尅	將	專	對											
小	9B90						尔	尠									
尢	9B90							尢	尮								
尸	9B90 9B9E		屐	屏	屛	屬				尸	尹	屮	屮	屮	屮	屮	
山	9B9E 9BAE 9BBE 9BCE	岬	岷	岷	岷	岷	岷	岷	岷	岷	岷	岷	岷	岷	岷	岷	岷
巛	9BCE																巛
工	9BDE	巫															
巳	9BDE		巳	卮													
巾	9BDE 9BEE	幟	幢	幣	幣	幣	帙	帙	帙	帶	帷	幄	幃	幃	幃	幃	幃
干	9BEE					干	井										
幺	9BEE						么	麼									
广	9BEE 9C3F	廖	廣	廡		廡	廡	廡	廡	廡	廡	廡	廡	廡	廡	廡	廡
廴	9C3F																廴 廴
井	9C4F	井	弃	井	井	井											
弋	9C4F						弋	弋									
弓	9C4F							弓	弓	弩	弭	弭	弭	彈	彌	彎	彎
彡	9C5F	彡	彡	彡	彡												
彣	9C5F					彣	彭										
彣	9C5F 9C6F	徙	徙	徠	徠	徠	徠	徠	徠	徠	徠	徠	徠	徠	徠	徠	徠
心	9C6F 9C80 9C90	怙	恂	恂	恂	恂	恂	恂	恂	恂	恂	恂	恂	恂	恂	恂	恂

	ShiftJIS	0	1	2	3	4	5	6	7	8	9	A	B	C	D	E	F
心	9C9E		悄	悛	悻	悵	悥	悦	悧	惡	悱	惠	倦	悴	悴	悽	惆
	9CAE	悵	悥	悦	悧	您	悩	悪	悫	惡	悱	惠	倦	悴	悴	悽	惆
	9CBE	悵	悥	悦	悧	您	悩	悪	悫	惡	悱	惠	倦	悴	悴	悽	惆
	9CCE	悵	悥	悦	悧	您	悩	悪	悫	惡	悱	惠	倦	悴	悴	悽	惆
	9CDE	悵	悥	悦	悧	您	悩	悪	悫	惡	悱	惠	倦	悴	悴	悽	惆
	9CEE	悵	悥	悦	悧	您	悩	悪	悫	惡	悱	惠	倦	悴	悴	悽	惆
戈	9CEE									戈	戍	戍	戍	戍	戔	戛	
	9D3F		戛	戔	戕					戛	戔	戕	戕				
戸	9D3F									扁							
手	9D3F										扎	扞	扣	扛	扞	扞	扼
	9D4F	扞	扞	扞	扞	扞	扞	扞	扞	扞	扞	扞	扞	扞	扞	扞	扞
	9D5F	扞	扞	扞	扞	扞	扞	扞	扞	扞	扞	扞	扞	扞	扞	扞	扞
	9D6F	扞	扞	扞	扞	扞	扞	扞	扞	扞	扞	扞	扞	扞	扞	扞	扞
	9D80	扞	扞	扞	扞	扞	扞	扞	扞	扞	扞	扞	扞	扞	扞	扞	扞
	9D90	扞	扞	扞	扞	扞	扞	扞	扞	扞	扞	扞	扞	扞	扞	扞	扞
	9D9E	扞	扞	扞	扞	扞	扞	扞	扞	扞	扞	扞	扞	扞	扞	扞	扞
	9DAE	扞	扞	扞	扞	扞	扞	扞	扞	扞	扞	扞	扞	扞	扞	扞	扞
支	9DAE														支	攴	攴
	9DBE	攴	攴	攴	攴	攴	攴	攴	攴	攴	攴	攴	攴	攴	攴	攴	攴
斗	9DBE																斛
	9DCE	斛															
斤	9DCE		斤	斤													
方	9DCE				旃	旃	旃	旃	旃	旃	旃	旃	旃				
无	9DCE											无	无	无			
日	9DCE														早	昊	昊
	9DDE	昊	昊	昊	昊	昊	昊	昊	昊	昊	昊	昊	昊	昊	昊	昊	昊
	9DEE	昊	昊	昊	昊	昊	昊	昊	昊	昊	昊	昊	昊	昊	昊	昊	昊
	9E3F	昊	昊	昊	昊	昊	昊	昊	昊	昊	昊	昊	昊	昊	昊	昊	昊
日	9E3F									日	日	日					
月	9E3F													肫	肫	肫	肫
	9E4F	肫	肫	肫	肫	肫	肫	肫	肫	肫	肫	肫	肫	肫	肫	肫	肫
木	9E4F			朮	朮	朮	朮	朮	朮	杆	杞	杠	杙	杙	杙	杰	杰
	9E5F	杰	杰	杰	杰	杰	杰	杰	杰	杰	杰	杰	杰	杰	杰	杰	杰
	9E6F	杰	杰	杰	杰	杰	杰	杰	杰	杰	杰	杰	杰	杰	杰	杰	杰

	ShiftJIS	0	1	2	3	4	5	6	7	8	9	A	B	C	D	E	F	
木	9E80	梳	柁	柁	档	桷	梲	梲	梲	梲	梭	梲	條	椰	梲	檣	柁	
	9E90	梳	柁	柁	档	桷	梲	梲	梲	梲	梭	梲	條	椰	梲	檣	柁	
	9E9E																	
	9EAE	換	倒	榆	楹	楷	榭	榭	榭	榭	榭	榭	榭	榭	榭	榭	榭	榭
	9EBE	榆	楞	棟	榭	榭	榭	榭	榭	榭	榭	榭	榭	榭	榭	榭	榭	榭
	9ECE	榻	檠	榭	榭	榭	榭	榭	榭	榭	榭	榭	榭	榭	榭	榭	榭	榭
	9EDE	榻	檠	榭	榭	榭	榭	榭	榭	榭	榭	榭	榭	榭	榭	榭	榭	榭
	9EEE	榻	檠	榭	榭	榭	榭	榭	榭	榭	榭	榭	榭	榭	榭	榭	榭	榭
	9F3F																	
	9F4F	檠	檠	檠	檠	檠	檠	檠	檠	檠	檠	檠	檠	檠	檠	檠	檠	檠
欠	9F4F								欸	欸	盜	欸	飲	欸	欸	欸	歐	
	9F5F	欸	欸	欸	欸	歡												
止	9F5F					歸												
歹	9F5F						歹	歹	歹	歹	歹	歹	歹	歹	歹	歹	歹	
	9F6F	殲	殲	殲	殲	殲												
殳	9F6F					殳	殳	殳	殳	殳								
母	9F6F									母	毓							
毛	9F6F											毳	毳	毳	毳	毳	毳	
	9F80	毳	毳															
氏	9F80			氏														
气	9F80			气	氛	氤	氣											
水	9F80							汞	汞	汕	汙	汪	沂	洵	沁	沛		
	9F90	汾	汨	汨	沒	沐	泄	決	泓	沽	泗	汪	沂	洵	沁	沛		
	9F9E																	
	9FAE	洌	洌	洌	沒	沐	泄	決	泓	沽	泗	汪	沂	洵	沁	沛		
	9FBE	洌	洌	洌	沒	沐	泄	決	泓	沽	泗	汪	沂	洵	沁	沛		
	9FCE	洌	洌	洌	沒	沐	泄	決	泓	沽	泗	汪	沂	洵	沁	沛		
	9FDE	洌	洌	洌	沒	沐	泄	決	泓	沽	泗	汪	沂	洵	沁	沛		
	9FEE	洌	洌	洌	沒	沐	泄	決	泓	沽	泗	汪	沂	洵	沁	沛		
	E03F	溱	溱	溱	溱	溱	溱	溱	溱	溱	溱	溱	溱	溱	溱	溱	溱	
	E04F	溱	溱	溱	溱	溱	溱	溱	溱	溱	溱	溱	溱	溱	溱	溱	溱	
E05F	溱	溱	溱	溱	溱	溱	溱	溱	溱	溱	溱	溱	溱	溱	溱	溱		
E06F	溱	溱	溱	溱	溱	溱	溱	溱	溱	溱	溱	溱	溱	溱	溱	溱		
火	E06F					炙	炒	炯	炯	炬	炸	炳	炳	炮	烟	焦	焦	

	ShiftJIS	0	1	2	3	4	5	6	7	8	9	A	B	C	D	E	F
火	E080 E090 E09E	烙 煩	焉 熨 燹	烽 熬 燿	焜 爛 爍	焙 熹 爐	煥 熾 爛	熙 燒 爨	熙 燉	煦 燂	煢 燎	煌 燠	煖 燬	煬 燧	熏 燧	燻 燼	熄
爪	E09E								爭	爬	爰	爲					
爻	E09E												爻	俎			
爿	E09E E0AE	牋	牘												牘	牘	牘
牛	E0AE			牴	牾	犁	犁	犇	犒	犖	犖	犖					
犬	E0AE E0BE E0CE	狎 猥	狒 猓	貉 獒	狼 獾	狡 默	狹 獬	狷 獯	倏 獨	猗 犖	猊 獸	猜 獵	狷 獻	豺 獾	狃 猴	狃 獾	狃 狃
王	E0CE E0DE E0EE	玻 瑁	珀 瑜	珥 瑩	珮 瑰	珞 瑣	璠 瑪	琅 瑤	瑯 瑾	琥 璋	珥 璞	球 璧	珞 瓊	瑕 瓏	珈 瓏	玳 瑁	玳 瑁
瓜	E13F		瓠	瓣													
瓦	E13F E14F	甕	甕	甕	甗	甗	瓮	甗	甗	甗	甗	甗	甗	甗	甗	甗	甗
甘	E14F				嘗												
生	E14F					甦											
用	E14F						甬										
田	E14F E15F	畧	畫	畎	疇	當	疆	旱	疇	畎	畎	畎	畎	畎	畎	畎	畎
疒	E15F E16F E180 E190 E19E	痲 瘰	疖 瘁	痲 癩	疖 癩	疽 癩	疽 癩	疼 癩	疱 癩	瘡 癩	瘡 癩	瘡 癩	瘡 癩	瘡 癩	疖 癩	疖 癩	疖 癩
灬	E19E		灬	癸	發												
白	E19E						皂	兒	飯	皐	皎	皖	皓	皙	皚		
皮	E19E E1AE	鞞	輝	皴												皴	皴
皿	E1AE				孟	盍	盍	盒	盞	盞	盞	盞	盞	盞			
目	E1AE E1BE	眇	眩	眈	眞	眈	眈	眈	眈	眈	睇	睇	睇	睇	眈	眈	眈

	ShiftJIS	0	1	2	3	4	5	6	7	8	9	A	B	C	D	E	F	
目	E1CE E1DE	睽 羸	睹 矚	瞎 矚	瞋	瞑	瞠	瞞	瞰	瞶	瞷	瞸	瞹	瞽	瞾	瞿	瞿	
矛	E1DE			矜														
矢	E1DE				矣	矮												
石	E1DE E1EE E23F	砗	砗 磧	砗 磚	砗 磧	砗 磧	砗 磧	砗 磧	砗 磧	礦 礎	砗 磧	砗 磧	砗 磧	碎 磅	砗 磊	砗 磬	砗 磬	
示	E23F E24F	祕	祕	祺	祿	禊	禊	禊	齋	禪	禮	禳	祀	祠	祗	崇	祚	
禺	E24F												禹	禹				
禾	E24F E25F E26F	秬	秬 穉	秬 穉	稈 穉	稍 穉	稈 穉	植	稠	稟	稟	稱	稻	稟	稟	稟	稟	
穴	E26F E280	窶	窶	窶	窿	邃	竇	竊	穿	窵	窗	窵	窘	窖	窩	竈	窰	
立	E280 E290	竝	竭	堙					計	奸	玆	玆	站	竝	竝	竝	竝	
竹	E290 E29E E2AE E2BE E2CE E2DE	筵	筵 筵	筵 筵	筵 筵	筵 筵	筵 筵	筵 筵	筵 筵	筵 筵	筵 筵	筵 筵	筵 筵	筵 筵	筵 筵	筵 筵	筵 筵	筵 筵
米	E2DE E2EE	糝	糝	糝	糝	粿	粿	粿	粿	粿	粿	粿	粿	粿	粿	粿	粿	
糸	E2EE E33F E34F E35F E36F E380 E390	絨	紂 紂	紂 紂	紂 紂	素	素	素	素	紂	紂	紂	紂	紂	紂	紂	紂	紂
缶	E390 E39E	罇	罇	罇	罇	罇	罇	罇	罇					缸	缸	缸	缸	

	ShiftJIS	0	1	2	3	4	5	6	7	8	9	A	B	C	D	E	F
网	E39E E3AE	網	罽	罽	罽	罽	网	罕		罔	罽	罽	罽	罽	罽	罽	罽
羊	E3AE E3BE	羴	羴	羴	羴	羴	羴	羴	羴	羴	羴	羴	羴	羴	羴	羴	羴
羽	E3BE		翊	翊	翊	翊	翊	翊	翊	翊	翊	翊	翊	翊	翊	翊	翊
老	E3BE													耆	耆	耆	耆
耒	E3CE	耒	耒	耒	耒	耒	耒	耒	耒								
耳	E3CE E3DE	聃	聃	聃	聃	聃	聃	聃	聃	聊	聆	聃	聃	聚	聃	聃	聃
聿	E3DE									聿	聿						
肉	E3DE E3EE E43F E44F E45F	胛	胛	胛	胛	胛	胛	胛	胛	胛	胛	胛	胛	胛	胛	胛	胛
臣	E45F									臧							
至	E45F										臺	臻					
臼	E45F E46F	與	舊											臾	舛	舛	舛
舌	E46F		舍	舐		舖											
舟	E46F E480	舳	舳	舳	舳	舳	舳	舳	舳	舳	舳	舳	舳	舳	舳	舳	舳
艮	E480					艮											
艸	E480 E490 E49E E4AE E4BE E4CE E4DE E4EE E53F E54F	苜	苜	苜	苜	苜	苜	苜	苜	艾	苜	苜	苜	苜	苜	苜	苜

	ShiftJIS	0	1	2	3	4	5	6	7	8	9	A	B	C	D	E	F
艸	E55F	蘋	蘋	藺	蘆	龍	蘇	蘊	蘿								
虍	E55F									虍	帀	虔	號	虧			
虫	E55F E56F E580 E590 E59E E5AE E5BE	蚩 蛟 蝥 螳 螳	蚪 蛛 蜻 蟪 墓 蠢	蚋 蛭 蜥 蝥 蠱	蚌 蛭 蜩 蜩 蠱	蚶 蜆 蠶 蠶 蠶	蚯 蜈 蝠 螢 蟲 蠹	蛄 蜀 蝟 螟 蟬 蠶	蛆 蜃 蝸 螂 蟻 蠶	蚰 蛭 蛭 蝮 蝮 蟻	蛉 蚤 蜉 蝻 蝻 蟻	螭 蝻 蝻 蝻 蝻 蟻	蝮 蝻 蝻 蝻 蝻 蟻	虱 蝻 蝻 蝻 蝻 蟻	蚓 蛭 蛭 蝻 蝻 蟻	蚣 蝻 蝻 蝻 蝻 蟻	蚣 蝻 蝻 蝻 蝻 蟻
血	E5BE									衄	衄						
行	E5BE											衙	衙	衛	衢		
衣	E5BE E5CE E5DE E5EE E63F	衾 袂 袂	袂 袂 袂 襦	袂 衾 襦 襦	衾 衾 襦 襦	衾 袂 袂 襦	袂 袂 袂 襦	袂 袂 袂 襦	袂 袂 袂 襦	袒 袂 褻	袂 袂 袂	袂 袂 袂	袂 袂 袂	袍 袂 袂	袂 袂 袂	衫 袂 袂	袁 袂 袂
而	E63F									而	覃	覈	羈				
見	E63F E64F	覲	覲	覲	覲	覺	覽	覲	覲					覲	覲	覲	覲
角	E64F									觚	觚	觚	觚	觚	觚		
言	E64F E65F E66F E680 E690 E69E	訐 詭 譎 譎 譎	訐 誣 誣 鞫 譎	訐 誣 誣 誣 譎	訐 誣 誣 誣 譎	訐 誣 誣 誣 譎	訐 誣 誣 誣 譎	訐 誣 誣 誣 譎	訐 誣 誣 誣 譎	訐 誣 誣 誣 譎	訐 誣 誣 誣 譎	訐 誣 誣 誣 譎	訐 誣 誣 誣 譎	訐 誣 誣 誣 譎	訐 誣 誣 誣 譎	訐 誣 誣 誣 譎	訐 誣 誣 誣 譎
谷	E69E E6AE	谿														谿	谿
豆	E6AE		豈	豈	豈	豈											
豕	E6AE						豕	豕	豕								
豸	E6AE E6BE	豸	豸	豸						豸	豸	豸	豸	豸	豸	豸	豸
貝	E6BE E6CE	賽	賺	賻	賻	賻	賻	賻	賻	貳	貳	貳	賈	賈	賈	賈	賈

	ShiftJIS	0	1	2	3	4	5	6	7	8	9	A	B	C	D	E	F
赤	E6CE E6DE	赭															赧
走	E6DE	走	赴	趁	趙												
足	E6DE E6EE E73F E74F	跟 踏	跣 蹇 躅	跣 蹇 躅	踣 躅	踣 躅	踣 躅	踣 躅	踣 躅	踣 躅	踣 躅	踣 躅	踣 躅	踣 躅	踣 躅	踣 躅	踣 躅
身	E74F E75F	軀	軀										躬	軀	軀	軀	軀
車	E75F E76F E780	輟 輟 輟	輟 輟 輟	輟 輟 輟	輟 輟 輟	輟 輟 輟	輟 輟 輟	輟 輟 輟	輟 輟 輟	輟 輟 輟	輟 輟 輟	輟 輟 輟	輟 輟 輟	輟 輟 輟	輟 輟 輟	輟 輟 輟	輟 輟 輟
辛	E780				辜	辟	辣	辭	辯								
辵	E780 E790 E79E E7AE	迓 迓 迓 迓	迹 迹 迹 迹	迓 迹 迹 迹	迓 迹 迹 迹	迓 迹 迹 迹	迓 迹 迹 迹	迓 迹 迹 迹	迓 迹 迹 迹	迓 迹 迹 迹	迓 迹 迹 迹	迓 迹 迹 迹	迓 迹 迹 迹	迓 迹 迹 迹	迓 迹 迹 迹	迓 迹 迹 迹	迓 迹 迹 迹
邑	E7AE E7BE	郛	郛	郛	郛				邨	邨	邨	邨	邨	邨	邨	邨	邨
酉	E7BE E7CE	醫	醢	醢	醢	醢	醢	醢	醢	醢	醢	醢	醢	醢	醢	醢	醢
采	E7CE									糶	釋						
里	E7CE												釐				
金	E7CE E7DE E7EE E83F E84F E85F E86F	釵 鈹 鈹 鎔 鐳 鑄	鈹 鈹 鈹 鎔 鐳 鑄	鈹 鈹 鈹 鎔 鐳 鑄	鈹 鈹 鈹 鎔 鐳 鑄	鈹 鈹 鈹 鎔 鐳 鑄	鈹 鈹 鈹 鎔 鐳 鑄	鈹 鈹 鈹 鎔 鐳 鑄	鈹 鈹 鈹 鎔 鐳 鑄	鈹 鈹 鈹 鎔 鐳 鑄	鈹 鈹 鈹 鎔 鐳 鑄	鈹 鈹 鈹 鎔 鐳 鑄	鈹 鈹 鈹 鎔 鐳 鑄	鈹 鈹 鈹 鎔 鐳 鑄	鈹 鈹 鈹 鎔 鐳 鑄	鈹 鈹 鈹 鎔 鐳 鑄	鈹 鈹 鈹 鎔 鐳 鑄
門	E86F E880 E890	閨 關	閨 關	閨 關	閨 關	閨 關	閨 關	閨 關	閨 關	閨 關	閨 關	閨 關	閨 關	閨 關	閨 關	閨 關	閨 關
阜	E890					阡	阡	阡	阡	阡	阡	阡	阡	阡	阡	阡	阡

	ShiftJIS	0	1	2	3	4	5	6	7	8	9	A	B	C	D	E	F
阜	E89E		陝	陟	陟	陞	陞	陞	陞	隕	隗	險	隧	隱	隲	隲	隲
隶	E8AE	隶	隸														
佳	E8AE			佳	隹	雋	雉	雍	襍	雜	霍	雕					
雨	E8AE E8BE	雲	霑	霏	霖	雲	雷	霆	霰	霹	霽	霏	霽	霄	霆	霽	霽
青	E8CE	靜															
非	E8CE		靠														
面	E8CE			飽	靦	靨											
革	E8CE E8DE					勒	鞞	鞞	鞞	鞞	鞞	鞞	鞞	鞞	鞞	鞞	鞞
韋	E8DE											韋	韋				
韭	E8DE													韭	齏	壘	
音	E8DE E8EE	韶	韻														竟
頁	E8EE E93F		頰	頰	頰	頰	頰	頰	頰	頰	頰	頰	頰	頰	頰	頰	頰
風	E93F					風	颯	颯	颯	颯	颯	颯					
食	E93F E94F E95F	舖	餘	餡	飭	餞	餞	餅	餽	饗	餽	餽	餽	餽	餽	餽	餽
首	E95F					馮	馮										
香	E95F																
馬	E95F E96F E980	駁	駱	駟	駟	駟	駟	駟	駟	馮	馮	馮	馮	駝	駝	駝	駝
骨	E980 E990	體	體	體	體									骸	骸	骸	骸
高	E990					髡											
髟	E990 E99E		髟	髟	髟	髟	髟	髟	髟	髟	髟	髟	髟	髟	髟	髟	髟
鬥	E99E									鬥	鬥	鬥	鬥	鬥	鬥		
鬯	E99E																鬯
鬼	E9AE	魄	魃	魏	魃	魃	魃	魃									

	ShiftJIS	0	1	2	3	4	5	6	7	8	9	A	B	C	D	E	F	
魚	E9AE E9BE E9CE E9DE	鮠 鮡 鮢 鮣	鮤 鮥 鮦 鮧	鮨 鮪 鮫 鮼	鮽 鮾 鮿 鮺	鮻 鮼 鮽 鮾	鮿 鮺 鮻 鮼	鮽 鮾 鮿 鮺	鮻 鮼 鮽 鮾	鮿 鮺 鮻 鮼	鮽 鮾 鮿 鮺	鮻 鮼 鮽 鮾	鮿 鮺 鮻 鮼	鮽 鮾 鮿 鮺	鮻 鮼 鮽 鮾	鮿 鮺 鮻 鮼	鮽 鮾 鮿 鮺	鮻 鮼 鮽 鮾
鳥	E9DE E9EE EA3F EA4F EA5F	鴉 鴛 鸚 鸚	鴛 鴛 鸚 鸚	鴛 鴛 鸚 鸚	鴛 鴛 鸚 鸚	鴛 鴛 鸚 鸚	鴛 鴛 鸚 鸚	鴛 鴛 鸚 鸚	鴛 鴛 鸚 鸚	鴛 鴛 鸚 鸚	鴛 鴛 鸚 鸚	鴛 鴛 鸚 鸚	鴛 鴛 鸚 鸚	鴛 鴛 鸚 鸚	鴛 鴛 鸚 鸚	鴛 鴛 鸚 鸚	鴛 鴛 鸚 鸚	鴛 鴛 鸚 鸚
鹵	EA5F				鹵	鹹	鹽											
鹿	EA5F						麋	麋	麋	麋	麋	麋	麋	麋	麋	麋	麋	麋
麥	EA5F EA6F																麥	麩
麻	EA6F				靡													
黃	EA6F					覺												
黍	EA6F						黎	黏	黏									
黑	EA6F EA80	黴	黴	黴						黔	黜	黜	黜	黜	黜	黜	黜	黜
耨	EA80				耨	耨	耨											
鼈	EA80						鼈	鼈		鼈								
鼓	EA80										鼓	鼗						
鼠	EA80												鼠	鼯				
鼻	EA80															鼷		
齊	EA80																齊	
齒	EA80 EA90	齧	齧	齧	齧	齧	齧	齧	齧	齧	齧	齧	齧					齒
龍	EA90													龍				
龜	EA90														龜			
龠	EA90																龠	

10.7 2D Code

SQR Code		ESC+2D33	
HEX code	ESC	2D33	Parameter
	<1B> ₁₆	<32> ₁₆ <44> ₁₆ <33> ₁₆ <33> ₁₆	,a,bb,c,d
Initial value	None		

Validity and valid duration of command	When the power switch is off	The set parameter is not maintained.
	Validity in a job	The set parameter becomes invalid.
	Validity after a job	The set parameter becomes invalid.

[Function]

Specifies security QR code of 2D code.

[Format] Setting portion

<2D33>,a,bb,c,d

• Parameter

- a [Error correction level] = L : 7%
M : 15%
Q : 25%
H : 30%
- b [Cell size] = 01 to 32 dots
* Specify 02 dots or higher in the head density of 12dot/mm, 04 dots or higher in the head density of 24dot/mm to be read by a scanner.
- c [Data setting mode] = 0 : Manual
1 : Automatic
*This setting affects the specification of print data.
- d [Concentration mode] = 0 : Normal mode (Fixed)

[Format] Data portion

Encryption key data specification

<DK>o~o

* [Input mode] can be automatically changed by the print data.

* Set the encrypted portion at the end and specify it only once within the command.

Manual setting (Data setting mode)

[Encrypted portion]

<DR>k,n~n

* When setting [Input mode] to [Numeric mode], [Alphanumeric mode] and [Kanji mode].

<DJ>mmmm,n~n

* This will be used for binary specification.

[Unencrypted portion]

<DS>k,n~n

* When setting [Input mode] to [Numeric mode], [Alphanumeric mode] and [Kanji mode]

<DN>mmmm,n~n

* This will be used for binary specification.

Automatic setting (Data setting mode)

[Encrypted portion]

<DJ>mmmm,n~n

* [Input mode] can be automatically changed by the input data.

[Unencrypted portion]

<DN>mmmm,n~n

* [Input mode] can be automatically changed by the input data.

• Parameter

- o [Encryption key] = Encryption key (Hexadecimal number 16-digit fixed)
* This setting needs to be specified only when encryption key is selected in data setting mode.
* Use the fixed 16-digit hexadecimal number for setting. If not, an error will occur.
- k [Input mode] = 1 : Numeric mode
2 : Alphanumeric mode
3 : Kanji mode (Shift JIS Kanji code)
*This setting is needed only when setting [Data setting mode] to [0: Manual].
*Binary specification is available for this setting, but the data specification command is different.
- m [Data number] = 0001 to 0486
*This setting is needed when setting [Data setting mode] to [1: Automatic], or selecting Binary in manual setting.
- n [Print data] = Data

[Note 1]

1. To specify Kanji mode with <DN> and <DJ>, specify the number of Kanji characters x 2 for the size.
2. The data of [80H to 9FH] and [EOH to FFH] will be handled as Kanji mode in automatic setting. It cannot be specified as Binary.
3. Security QR code is not supporting the concentration mode.
4. To specify the data, be sure to set it in the following order: key → encrypted portion → unencrypted portion.
5. The result of data reading will be shown in the following order: unencrypted portion → encrypted portion.

6. If the encryption key is not specified at the time of power on, the encryption key will be "0000000000000000".
7. If an error occurs in the encryption key setting, the previously set encryption key will be valid.
8. If only the unencrypted portion is specified without setting the encrypted portion in data setting, QR code will be printed.
On the other hand, if specifying the encrypted portion only, QR code will not be printed.

[Example 1] Error correction level: 7% Cell size: 05
 Data setting mode: Manual

```
<A>
<V>100<H>200
<2D33>.L.05.0.0
<DK>0123456789ABCDEF
<DR>1.0310
<DS>2.SATO
<Q>2
<Z>
```

[Note 2]

1. When designating the parameter other than specified or when the number of print data is not matching, printing will not be performed.
2. For data portion, the data specification command may differ depending on the parameter settings or specified data contents.

[Example 2] Multiple data specification in manual setting (Data setting mode)

The data of input mode (numeric, alphanumeric, Kanji, binary), specified in data portion, can be specified consecutively.

```
<A>
<V>100<H>200
<2D33>.L.12.0.0
<DK>0123456789ABCDEF
<DR>1.0310
<DR>2.SATO
<DS>2.SINCE
<DS>1.1940
<Q>1
<Z>
```

[Note 3]

1. Parameter portion is followed by data portion. Data portion is followed by other data portion consecutively. If the data is not specified consecutively, printing may not be performed properly.
2. Keep the total data number(n) under 7,000 bytes. Data portion to be specified consecutively is up to 200.

QR Data Size (Model 2)

Version	Error Correction	Numeric	Alpha-numeric	Kanji	Binary	Version	Error Correction	Numeric	Alpha-numeric	Kanji	Binary
21 × 21	L	41	25	10	17	61 × 61	L	772	468	198	321
	M	34	20	8	14		M	604	366	155	251
	Q	27	16	7	11		Q	427	259	109	177
	H	17	10	4	7		H	331	200	85	137
25 × 25	L	77	47	20	32	65 × 65	L	883	535	226	367
	M	63	38	16	26		M	691	419	177	287
	Q	48	29	12	20		Q	489	296	125	203
	H	34	20	8	14		H	374	227	96	155
29 × 29	L	127	77	32	53	69 × 69	L	1022	619	262	425
	M	101	61	26	42		M	796	483	204	331
	Q	77	47	20	32		Q	580	352	149	241
	H	58	35	15	24		H	427	259	109	177
33 × 33	L	187	114	48	78	73 × 73	L	1101	667	282	458
	M	149	90	38	62		M	871	528	223	362
	Q	111	67	28	46		Q	621	376	159	258
	H	82	50	21	34		H	468	283	120	194
37 × 37	L	255	154	65	106	77 × 77	L	1250	758	320	520
	M	202	122	52	84		M	991	600	254	412
	Q	144	87	37	60		Q	703	426	180	292
	H	106	64	27	44		H	530	321	136	220
41 × 41	L	322	195	82	134	81 × 81	L	1408	854	361	586
	M	255	154	65	106		M	1082	656	277	450
	Q	178	108	45	74		Q	775	470	198	322
	H	139	84	36	58		H	602	365	154	250
45 × 45	L	370	224	95	154	85 × 85	L	1548	938	397	644
	M	293	178	75	122		M	1212	734	310	504
	Q	207	125	53	86		Q	876	531	224	364
	H	154	93	39	64		H	674	408	173	280
49 × 49	L	461	279	118	192	89 × 89	L	1725	1046	442	718
	M	365	221	93	152		M	1346	816	345	560
	Q	259	157	66	108		Q	948	574	243	394
	H	202	122	52	84		H	746	452	191	310
53 × 53	L	552	335	141	230	93 × 93	L	1903	1153	488	792
	M	432	262	111	180		M	1500	909	384	624
	Q	312	189	80	130		Q	1063	644	272	442
	H	235	143	60	98		H	813	493	208	338
57 × 57	L	652	395	167	271	97 × 97	L	2061	1249	528	858
	M	513	311	131	213		M	1600	970	410	666
	Q	364	221	93	151		Q	1159	702	297	482
	H	288	174	74	119		H	919	557	235	382

Version	Error correction	Numeric	Alpha-numeric	Kanji	Binary	Version	Error correction	Numeric	Alpha-numeric	Kanji	Binary
2 1 101 × 101	L	2232	1352	572	929	3 1 141 × 141	L	4417	2677	1132	1840
	M	1708	1035	438	711		M	3486	2113	894	1452
	Q	1224	742	314	509		Q	2473	1499	634	1030
	H	969	587	248	403		H	1897	1150	486	790
2 2 105 × 105	L	2409	1460	618	1003	3 2 145 × 145	L	4686	2840	1201	1952
	M	1872	1134	480	779		M	3693	2238	947	1538
	Q	1358	823	348	565		Q	2670	1618	684	1112
	H	1056	640	270	439		H	2022	1226	518	842
2 3 109 × 109	L	2620	1588	672	1091	3 3 149 × 149	L	4965	3009	1273	2068
	M	2059	1248	528	857		M	3909	2369	1002	1628
	Q	1468	890	376	611		Q	2805	1700	719	1168
	H	1108	672	284	461		H	2157	1307	553	898
2 4 113 × 113	L	2812	1704	721	1171	3 4 153 × 153	L	5253	3183	1347	2188
	M	2188	1326	561	911		M	4134	2506	1060	1722
	Q	1588	963	407	661		Q	2949	1787	756	1228
	H	1228	744	315	511		H	2301	1394	590	958
2 5 117 × 117	L	3057	1853	784	1273	3 5 157 × 157	L	5529	3351	1417	2303
	M	2395	1451	614	997		M	4343	2632	1113	1809
	Q	1718	1041	440	715		Q	3081	1867	790	1283
	H	1286	779	330	535		H	2361	1431	605	983
2 6 121 × 121	L	3283	1990	842	1367	3 6 161 × 161	L	5836	3537	1496	2431
	M	2544	1542	652	1059		M	4588	2780	1176	1911
	Q	1804	1094	462	751		Q	3244	1966	832	1351
	H	1425	864	365	593		H	2524	1530	647	1051
2 7 125 × 125	L	3517	2132	902	1465	3 7 165 × 165	L	6153	3729	1577	2563
	M	2701	1637	692	1125		M	4775	2894	1224	1989
	Q	1933	1172	496	805		Q	3417	2071	876	1423
	H	1501	910	385	625		H	2625	1591	673	1093
2 8 129 × 129	L	3669	2223	940	1528	3 8 169 × 169	L	6479	3927	1661	2699
	M	2857	1732	732	1190		M	5039	3054	1292	2099
	Q	2085	1263	534	868		Q	3599	2181	923	1499
	H	1581	958	405	658		H	2735	1658	701	1139
2 9 133 × 133	L	3909	2369	1002	1628	3 9 173 × 173	L	6743	4087	1729	2809
	M	3035	1839	778	1264		M	5313	3220	1362	2213
	Q	2181	1322	559	908		Q	3791	2298	972	1579
	H	1677	1016	430	698		H	2927	1774	750	1219
3 0 137 × 137	L	4158	2520	1066	1732	4 0 177 × 177	L	7089	4296	1817	2953
	M	3289	1994	843	1370		M	5596	3391	1435	2331
	Q	2358	1429	604	982		Q	3993	2420	1024	1663
	H	1782	1080	457	742		H	3057	1852	784	1273

10.8 2D Code

DataMatrix (ECC200)		ESC+2D50	
HEX code	ESC	2D50	Parameter
	<1B> ₁₆	<32> ₁₆ <44> ₁₆ <35> ₁₆ <30> ₁₆	,aa,bb,ccc,ddd
Initial value	None		

Validity and valid duration of command	When the power switch is off	The set parameter is not maintained.
	Validity in a job	The set parameter becomes invalid.
	Validity after a job	The set parameter becomes invalid.

[Function]

Specifies GS1 DataMatrix code (ECC200) of 2D code.

[Format] Setting portion

<2D50>,aa,bb,ccc,ddd

•Parameter

a	[Cell width]	= 01 to 16 dots
b	[Cell pitch]	= 01 to 16 dots
c	[Number of cells per line]	= 000 fixed
d	[Number of cell line]	= 000 fixed

[Format] Data portion

<DN>mmmm,n~n

•Parameter

m [Data number] = 0001 to 3116

n [Print data] = Data

* When selecting [7EH], make sure to specify [7EH,7EH].

* When designating the parameter other than specified or when the number of print data is not matching, printing will not be performed.

[Example] Cell width : 3 dots Cell pitch : 3 dots

<A>

<V>100<H>200<2D50>**03.03.000.000**

<DN>0010,0123456789

<Z>



[Note]

- When designating the parameter other than specified or when the number of print data is not matching, printing will not be performed.
- When specifying the print format, make sure to have more than 2mm margins all around DataMatrix (ECC200) to be read with a scanner.
- When print data is [7EH], specify [7EH,7EH]. Data number becomes [0002].
- Setting [Data number] to its maximum value may cause a command error depending on the pattern of print data.
- For cell size, specify 02 dots or higher in the head density of 12 dot/mm and 04 dots or higher in the head density of 24 dot/mm to be read by a scanner.

	Data format	Data number
Data format	Numeric	3116
	Alphanumeric	2335
	Binary (01H to FFH)	1556

DataMatrix (ECC200) code table

				S				I				S				O					
				b8	0	0	0	0	0	0	0	0	0	1	1	1	1	1	1	1	1
				b7	0	0	0	0	1	1	1	1	0	0	0	0	1	1	1	1	
				b6	0	0	1	1	0	0	1	1	0	0	1	1	0	0	1	1	
				b5	0	1	0	1	0	1	0	1	0	1	0	1	0	1	0	1	
b4	b3	b2	b1		0	1	2	3	4	5	6	7	8	9	A	B	C	D	E	F	
0	0	0	0	0			SP	0	@	P	`	p									
0	0	0	1	1			!	1	A	Q	a	q									
0	0	1	0	2			"	2	B	R	b	r									
0	0	1	1	3			#	3	C	S	c	s									
0	1	0	0	4			\$	4	D	T	d	t									
0	1	0	1	5			%	5	E	U	e	u									
0	1	1	0	6			&	6	F	V	f	v									
0	1	1	1	7			'	7	G	W	g	w									
1	0	0	0	8			(8	H	X	h	x									
1	0	0	1	9)	9	I	Y	i	y									
1	0	1	0	A			*	:	J	Z	j	z									
1	0	1	1	B			+	;	K	[k	{									
1	1	0	0	C			,	<	L	¥	l										
1	1	0	1	D			-	=	M]	m	}									
1	1	1	0	E			.	>	N	^	n	~									
1	1	1	1	F			/	?	O	_	o	DEL									

Data Matrix (ECC200) is settable within the range of 01H to FFH.

To set 7EH, specify [7EH, 7EH].

* 00H cannot be specified.

11. Composite Symbol Commands

11.1 Composite Symbol

Composite Symbol		ESC+EU	
HEX code	ESC <1B> ₁₆	EU <45> ₁₆ <55> ₁₆	Parameter aabb(cc)(ddd)n~n
Initial value	None		

Validity and valid duration of command	When the power switch is off	The set parameter is not maintained.
	Validity in a job	The set parameter becomes invalid.
	Validity after a job	The set parameter becomes invalid.

[Function]

Specifies composite symbol.

[Format 1]

<EU>aabbccn~n

•Parameter

- a [1D barcode symbology] = 01: GS1 DataBar Composite(CC-A/CC-B)
 02: GS1 DataBar Truncated Composite(CC-A/CC-B)
 03: GS1 DataBar Stacked Composite(CC-A/CC-B)
 04: GS1 DataBar Stacked Omni-Directional Composite(CC-A/CC-B)
 05: GS1 DataBar Limited Composite(CC-A/CC-B)
 06: GS1 DataBar Expanded Composite(CC-A/CC-B)
 07: UPC-A Composite(CC-A/CC-B)
 08: UPC-E Composite(CC-A/CC-B)
 09: EAN-13 Composite(CC-A/CC-B)
 10: EAN-8 Composite(CC-A/CC-B)
- b [Minimum bar width] = 01 to 12 dots
- c [Segment width] = 02 to 22 dots
 (Supporting GS1 DataBar Expanded Composite(CC-A/CC-B) only. Omit others.)
- n [Print data] = Barcode data

Designable maximum digit number for 1D data

GS1 DataBar Composite(CC-A/CC-B)	13-digit
GS1 DataBar Truncated Composite(CC-A/CC-B)	13-digit
GS1 DataBar Stacked Composite(CC-A/CC-B)	13-digit
GS1 DataBar Stacked Omni-Directional Composite(CC-A/CC-B)	13-digit
GS1 DataBar Limited Composite(CC-A/CC-B)	13-digit
GS1 DataBar Expanded Composite(CC-A/CC-B)	74-digit
UPC-A Composite(CC-A/CC-B)	11-digit
UPC-E Composite(CC-A/CC-B)	Fixed 10-digit
Specify 1D data in the format of "XX00000XXX"(X is variable portion)	
EAN-13 Composite(CC-A/CC-B)	12-digit
EAN-8 Composite(CC-A/CC-B)	7-digit

[Note]

1. Check digit is automatically calculated and added.
2. To specify the print of composite symbol, delimit 1D data and 2D data with ' | '(7CH).
 e.g.) Data = 1D data | 2D data
3. Specify 1D data from the 1st to the 16th digit of GS1 DataBar Expanded Composite(CC-A/CC-B).
4. For GS1 DataBar Expanded Composite(CC-A/CC-B), up to 74-digit of numeric including 1D data, and 41-digit of alphabet can be entered.
 (Up to 41-digit of alphanumeric including 1D data can be entered)
5. If the digit number specified is smaller than the maximum digit number for 1D data, this value will be zero filled at the front end. (Except GS1 DataBar Expanded Composite(CC-A/CC-B))
6. In 2D data, up to 338-digit can be entered. Depending on the barcode symbologies, maximum digit number can be entered may vary.

[Format 2]

<EU>aabbddn~n

• Parameter

a [1D barcode symbology] = 11 : GS1-128 Composite (CC-A/CC-B)
12 : GS1-128 Composite (CC-C)

b [Minimum bar width] = 01 to 12 dots

ddd [Height of barcode] = 001 to 500 dots
Specify the value of [Height of barcode] when setting [Minimum bar width] to [01].
For example, if setting [Minimum bar width] to [03] and [Height of barcode] is [100],
[Height of barcode] will be 300 dots.

n [Print data] = Data

Designable maximum digit number for the sum of 1D and 2D data (Constraints on maximum digit number of 1D data)

GS1-128 Composite (CC-A/CC-B)	338-digit
GS1-128 Composite (CC-C)	2361-digit

Designable maximum digit number for 1D data

GS1-128 Composite (CC-A/CC-B)	48-digit
GS1-128 Composite (CC-C)	48-digit

* To specify the print of composite symbol, delimit 1D data and 2D data with |(7CH).

e.g.) Data = 1D data | 2D data

* To specify FNC1(GS) of GS1-128 Composite (CC-C)(PDF417 specification) as data, use #(23H).

[Note]

- Parameter feature varies depending on 1D barcode symbologies.
Only GS1 DataBar Expanded Composite(CC-A/CC-B)(EU06) is designable for segment width.
Parameter for height of barcode can be specified for GS1-128 Composite(CC-A/CC-B/CC-C)(EU11,EU12) only.
- If the correct value for 1D barcode symbology is not set in the data portion, composite symbol will not be printed.
- The sum of 1D and 2D data up to 2361-digit can be set for the print data parameter. As for 2D data, when 1D barcode symbology and alphanumeric are mixed, the number of designable data may vary.
If specifying the data exceeding the maximum digit number, barcodes may not be printed properly.
- Entire size of composite symbol changes depending on the specification of minimum bar width.
- If composite symbol exceeds the printable area, only the portion within the area will be printed; however, a scanner might read the value of such composite symbol occasionally.
- In the specification of composite symbol, 1D barcode data affects the width and height of 2D barcode. When the 1D barcode width is very small, specifying the data with the valid digit number will not print anything.
- Print of HRI cannot be designated with this command.
- The Rotate <%> command is available, but not the Character Expansion <L> command.

Composite symbol 2D code table

				S				I				S				O			
b8				0	0	0	0	0	0	0	0	1	1	1	1	1	1	1	1
b7				0	0	0	0	1	1	1	1	0	0	0	0	1	1	1	1
b6				0	0	1	1	0	0	1	1	0	0	1	1	0	0	1	1
b5				0	1	0	1	0	1	0	1	0	1	0	1	0	1	0	1
b4	b3	b2	b1	0	1	2	3	4	5	6	7	8	9	A	B	C	D	E	F
0	0	0	0	0			SP	0		P		p							
0	0	0	1	1			!	1	A	Q	a	q							
0	0	1	0	2			"	2	B	R	b	r							
0	0	1	1	3				3	C	S	c	s							
0	1	0	0	4				4	D	T	d	t							
0	1	0	1	5			%	5	E	U	e	u							
0	1	1	0	6			&	6	F	V	f	v							
0	1	1	1	7			'	7	G	W	g	w							
1	0	0	0	8			(8	H	X	h	x							
1	0	0	1	9)	9	I	Y	i	y							
1	0	1	0	A			*	:	J	Z	j	z							
1	0	1	1	B			+	;	K		k								
1	1	0	0	C			,	<	L		l								
1	1	0	1	D			-	=	M		m								
1	1	1	0	E			.	>	N		n								
1	1	1	1	F			/	?	O	_	o								

* To select FNC1, specify # (23H).

12. Graphic Commands

12.1 Graphic			
Custom Graphics			ESC+G
HEX code	ESC	G	Parameter
	<1B> ₁₆	<47> ₁₆	abbbccn~n
Initial value	None		
Validity and valid duration of command	When the power switch is off	The set parameter is not maintained.	
	Validity in a job	The set parameter becomes invalid.	
	Validity after a job	The set parameter becomes invalid.	

[Function]

Prints graphic images.

[Format]

<G>abbbccn~n

•Parameter

- a [Data specification by HEX and BIN]
 - H: HEX data Divide 8 bits data into 4 bits , and output it as HEX code corresponding to ASCII.
 - B: Binary data Outputs 8 bits data as one font data all at once.
- b [Crosswise graphic area per byte] See the table below
- c [Lengthwise graphic area per byte] See the table below
- n [Graphic data]

[Example]

```
<A>
<V>50<H>50<G>H02000288888888...8888
<Q>2
<Z>
```

[Note]

1. Specification of "B" has a longer program description than that of "H"; on the other hand, its transfer data length is 50% shorter.
2. The Rotate <%> and Character Expansion <L> commands are enabled.
3. The Character Expansion <L> command must be sent right before this <G> command.
4. Place the Rotation <%> command followed by the Character Expansion <L> command when using with this <G> command.

[Parameter initial value and specified range]

Printer model	Maximum byte for crosswise graphic area	Maximum byte for lengthwise graphic area
HR212	84	300
HR224	168	600

12.2 Graphic			
BMP File			ESC+GM
HEX code	ESC <1B> ₁₆	GM <47> ₁₆ <4D> ₁₆	Parameter aaaaa,n~n
Initial value	None		
Validity and valid duration of command	When the power switch is off	The set parameter is not maintained.	
	Validity in a job	The set parameter becomes invalid.	
	Validity after a job	The set parameter becomes invalid.	

[Function]

Specifies the print or BMP file created by such as Paint Brush of Windows.

[Format]

<GM>aaaaa,n~n

• Parameter

a [Total bytes of BMP file]

n [Data]

[Example]

<A>

<V>50<H>50<GM>04500,200028888888...8888

<Q>2

<Z>

[Note]

1. Data is sent in binary data (Outputs 8-bit data as 1 font data all at once). (BMP file size becomes the total bytes and BMP file data becomes the data.)
2. In BMP file, first 62-byte data is for the header part and the rest of data is compressed.
3. When [Total bytes of BMP file] is not matching the transfer data, this may become the cause of malfunction.
4. Total bytes are the file size displayed at [Property] and such.
5. BMP file is available in Black/White mode only. In color mode, printing will not be performed due to command error. Also, this command is not valid for BMP compressed file.
Make sure that the file extension is set to [BMP] before printing.
6. The Rotate <%> and Character Expansion <L> commands are enabled.
7. The Character Expansion <L> command must be sent right before this <GM> command.
8. Place the Rotation <%> command followed by the Character Expansion <L> command.

13. System Command

13.1 System			
Print Speed			ESC+CS
HEX code	ESC	CS	Parameter
	<1B> ₁₆	<43> ₁₆ <53> ₁₆	a(.b)
Initial value	See the table below		
Validity and valid duration of command	When the power switch is off	The set parameter is maintained.	
	Validity in a job	The set parameter is valid until a new command is specified.	
	Validity after a job	The set parameter is valid until a new command is specified.	

[Function]

Specifies print speed.

[Format]

<CS>a.b

•Parameter

a(.b) [Print speed] = See the table below (".b" is omissible)

[Example]

<A>

<CS>3.0

<Z>

[Note]

1. Print speed specified by this command or by the setting through the printer LCD will be maintained.
2. Print speed can be also set by the printer setting tool stored in the accessory CD-ROM.

[Tip]

1. If the value other than setting range is specified, command error will occur and print speed will not be changed.
2. Reset the setting by default setting operation of the printer.

[Parameter initial value and valid range]

Initial value	Parameter valid range	Print speed corresponding to parameter
2.0	1.0 to 4.0	1.0 : 1.0 inch/sec (25 mm/sec) 1.5 : 1.5 inch/sec (37.5mm/sec) 2.0 : 2.0 inch/sec (50 mm/sec) 2.5 : 2.5 inch/sec (62.5mm/sec) 3.0 : 3.0 inch/sec (75 mm/sec) 3.5 : 3.5 inch/sec (87.5mm/sec) 4.0 : 4.0 inch/sec (100 mm/sec)

13.2 System			
Print Darkness			ESC+#E
HEX code	ESC	#E	Parameter
	<1B> ₁₆	<23> ₁₆ <45> ₁₆	a(b)
Initial value	See the table below		

Validity and valid duration of command	When the power switch is off	The set parameter is maintained.
	Validity in a job	The set parameter is valid until a new command is specified.
	Validity after a job	The set parameter is valid until a new command is specified.

[Function]

Specifies the darkness level of print.

[Format]

<#E>a(b)

•Parameter

- a [Print darkness] = 1 to 5
 - b [Darkness range] = A to F (Omissible)
- Use [A] or [B] under normal conditions.

[Example]

<A>
<#E>3
 <Z>

[Note]

1. Print darkness specified by this command or by the setting through the printer LCD will be maintained.
2. Print darkness can be also set by the printer setting tool stored in the accessory CD-ROM.

[Tip]

1. If the value other than setting range is specified, command error will occur and print darkness will not be changed.
2. Reset the setting by default setting operation of the printer.

[Initial value and valid range of Parameter "a"]

Initial value	Parameter valid range
3 : Normal	1 : Lightest 2 : Light 3 : Normal 4 : Dark 5 : Darkest

13.4 System

Base Reference Point		ESC+A3	
HEX code	ESC <1B> ₁₆	A3 <41> ₁₆ <33> ₁₆	Parameter V(a)bbbH(c)ddd
Initial value	a=+, b=000, c=+, d=000		

Validity and valid duration of command	When the power switch is off	The set parameter is not maintained.
	Validity in a job	The set parameter is valid until a new command is specified.
	Validity after a job	The set parameter is valid until a new command is specified.

[Function]

Changes the base reference point position. Go to the User Mode through printer LCD for setting.

[Format]

<A3>V(a)bbbH(c)ddd

•Parameter

a	Plus / Minus sign for vertical print offset	= +, - (Omissible)
b	Vertical print offset (dots)	= 0 to 792 dots * If "+" or "-" is not specified, 1 to 792 dots
c	Plus / Minus sign for horizontal print offset	= +, - (Omissible)
d	Horizontal print offset (dots)	= 0 to 792 dots * If "+" or "-" is not specified, 1 to 792 dots

[Example]

<A>

<A3>V+10H+10

<Z>

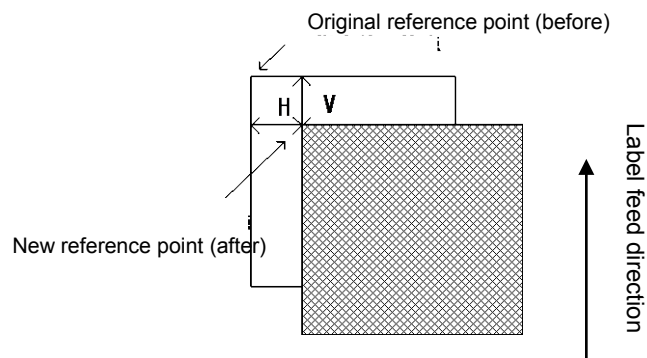

[Note]

1. If changing the reference point and it is located outside of printable area, printing may not be performed.
2. When changing the reference point through multiple label formats, correction will be made to all the formats.

[Tip]

1. If using this command, the value specified by this command will become effective regardless of the base reference point set by User Mode through the printer LCD,
2. Base reference point specified by this command will not be stored in User Mode of the printer.
This specified value will be maintained until a new command is executed or after turning off the printer.

13.5 System			
Clear			ESC+*
HEX code	ESC	*	Parameter
	<1B> ₁₆	<2A> ₁₆	a
Initial value	None		
Validity and valid duration of command	When the power switch is off		The set parameter is not maintained.
	Validity in a job		The set parameter becomes invalid.
	Validity after a job		The set parameter becomes invalid.

[Function]

Clears individual memory and buffer.

[Format]

<*>a

• Parameter

a [Memory section to be cleared] = Without specification: Single item receive buffer, editing buffer (No reprint)
 Multi item buffer, editing buffer (Clears JOB while printing)

T : External character registration area
 & : Form overlay
 X : Clears all
 (Receive buffer, editing buffer, external character registration, form overlay)
 Not clearing the item currently being printed.

S : Sub port receive data
 H : History of STATUS5

[Example 1] Clears receive buffer and editing buffer

<A>
 <*>
 <Z>

[Example 2] Clears all

<A>
 <*>X
 <Z>

[Example 3] Clears external character registration area

<A>
 <*>T
 <Z>

[Note]

1. Place this command between the Start Code <A> command and the Stop Code <Z> command.
2. Sending [a=X] will clear all the data sent before the execution of this clear command. And also, registration of external character and form overlay will be cleared. In this case, the analyzed data while printing can not be cleared.

[Tip]

1. To send the next data, wait more than 100ms after sending this command.
2. Specification of this command while printing will not stop the print operation.

13.6 System

Offline		ESC+@	
HEX code	ESC <1B> ₁₆	@ <40> ₁₆	Parameter None
Initial value	None		

Validity and valid duration of command	When the power switch is off	The set command is not maintained.
	Validity in a job	The set command becomes invalid.
	Validity after a job	The set command becomes invalid.

[Function]

Changes the printer from online to offline status.

[Format]

<@>

[Example]

<A>

<@>

<Z>

[Note]

1. Place this command between the Start Code <A> command and the Stop Code <Z> command.
2. In receive mode of the printer, specify single-item buffer mode.

13.7 System

Repeat		ESC+C	
HEX code	ESC <1B> ₁₆	C <43> ₁₆	Parameter None
Initial value	None		

Validity and valid duration of command	When the power switch is off	The set command is not maintained.
	Validity in a job	The set command becomes invalid.
	Validity after a job	The set command becomes invalid.

[Function]

Prints a duplicate of the last label printed.

[Format]

<C>

[Example]

<A>

<C>

<Z>

[Note]

1. Turning off the printer clears the print data; therefore, a duplicate of the previous label cannot be printed with this command.

[Tip]

1. To print a duplicate of format including the field of Sequential Numbering <F> command, the print data previously issued is printed.

13.8 System

Printer Setup		ESC+PG	
HEX code	ESC <1B> ₁₆	PG <50> ₁₆ <47> ₁₆	Parameter abcdefghijklmnopppqrstuvwxyz
Initial value	See the table on the following page		

Validity and valid duration of command	When the power switch is off	The set parameter is maintained.
	Validity in a job	The set parameter is valid until a new command is specified.
	Validity after a job	The set parameter is valid until a new command is specified.

[Function]

Saves the printer settings.

[Format]

<PG>abcdefghijklmnopppqrstuvwxyz

- Parameter
See the table on the following page.

[Example]

<A>

<PG><00 00 02 00 00 00 00 41 01 00 00 00 00 00 0C 80 03 40 00 00 00 05 00 00 00 00 00>₁₆

<Z>

Parameter is described in HEX <00H>₁₆<00H>₁₆<02H>₁₆ <00H>₁₆

[Note]

1. This command is not necessary in the normal print operation.
2. Printer settings specified by this command will remain in effect after turning off the printer.
3. Do not execute this command while printing. Doing so may result in disabling the sensor.

[Tip]

1. Various settings can be done without using this command. See the table on the next page.
2. Printer settings can be done through the printer LCD without using this command.

No	Item	Description
a	Print mode (Initial value: 00H)	00H Thermal transfer * 01H Cannot be changed to direct thermal
b	Reserved	00H Fixed
c	Print speed (Initial value: 02H) (Range: 1.0 to 4.0 inch/sec)	01H 1.0 inch/sec 02H 1.5 inch/sec 03H 2.0 inch/sec 04H 2.5 inch/sec 05H 3.0 inch/sec 06H 3.5 inch/sec 07H 4.0 inch/sec
d	Printer type (Initial value: 00H)	00H Continuous 01H Tear off 03H Dispenser
e	Reserved	00H Fixed
f	Dispenser motion	00H Motion 1 (Thermal head position) 01H Motion 2 (Dispensing position)
g	Reserved	00H Fixed
h	Darkness range (Initial value: 41H)	41H A 42H B 43H C 44H D 45H E 46H F
	Print darkness (Initial value: 03H)	01H 1 02H 2 03H 3 04H 4 05H 5
i	Sensor type (Initial value: 01H)	00H I-MARK 01H GAP1 02H GAP2 03H GAP3 04H GAP4
j	Zero slash (Initial value: 00H)	00H No 01H Yes
k	Character code (Initial value: 00H)	00H JIS code 01H Shift JIS code 02H Unicode
l	Reserved	00H Fixed
m	Auto online feed (Initial value: 00H)	00H No 01H Yes
n	Character pitch (Initial value: 00H)	00H Fixed 01H Proportional
o	Label height in dots (2-byte specification)	HR212 : [0001H to 0960H] (1 to 2400) HR224 : [0001H to 12C0H] (1 to 4800)
p	Label width in dots (2-byte specification)	HR212 : [0001H to 02A0H] (1 to 672) HR224 : [0001H to 0540H] (1 to 1344)
q	Vertical pitch offset in dots (2-byte specification)	[0000H to 0318H] (0 to 792) [FFFFH to FCE8H] (-1 to -792)
r	Horizontal pitch offset in dots (2-byte specification)	[0000H to 0318H] (0 to 792) [FFFFH to FCE8H] (-1 to -792)
s	Waiting time for tear off (by 100ms) (Initial value: 010)	[05H to C8H] (5 to 200)
t	LCD power saving (by minute) (Initial value: 00 minute)	[00H to 0FH] (0 to 15)

No	Item	Description
u	Reserved	00H Fixed
v	Reserved	00H Fixed
w	Reserved	00H Fixed
x	Reserved	00H Fixed
y	Buzzer (Initial value: 00H)	00H Yes 01H No

The contents set by this command can be configured by using the printer setting tool stored in the accessory CD-ROM.

13.9 System

Line Feed		ESC+E	
HEX code	ESC <1B> ₁₆	E <45> ₁₆	Parameter aaa
Initial value	None		

Validity and valid duration of command	When the power switch is off	The set parameter is not maintained.
	Validity in a job	The set parameter becomes invalid.
	Validity after a job	The set parameter becomes invalid.

[Function]

Specifies the line pitch and linefeed.

[Format]

<E>aaa

- Parameter

a [Number of dots between each line] = 0 to 999 dots

[Example]

<A>

<E>10

<V>100<H>200<P>2<L>0304<X22>,ABCDE + CR

FGHIJ + CR

<Q>2

<Z>

[Note]

1. When CR(ODH) is specified, line feed based on line pitch will be performed.
2. The Rotate <%> command is enabled.
3. Line pitch can be changed with this command within a job.
4. Specify this command before designating the consecutive print of 1-line.
5. Performing auto linefeed by the designation of CR(ODH), print start position of linefeed will be determined based on the pitch specified with <E> and the value specified with the Horizontal Print Position <H> command designated after <E>. In case that <H> is specified several times after <E>, return position by CR (ODH) will be at the last <H>.

13.10 System

Sensor Type		ESC+IG	
HEX code	ESC <1B> ₁₆	IG <49> ₁₆ <47> ₁₆	Parameter a
Initial value	a=1		

Validity and valid duration of command	When the power switch is off	The set parameter is not maintained.
	Validity in a job	The set parameter is valid until a new command is specified.
	Validity after a job	The set parameter is valid until a new command is specified.

[Function]

Selects sensor type.

[Format]

<IG>a

• Parameter

a [Sensor type] = 0 : Reflective sensor (I-Mark)
1 : Transmissive sensor (GAP1)
5 : Transmissive sensor (GAP2)
6 : Transmissive sensor (GAP3)
7 : Transmissive sensor (GAP4)

[Example]

<A>

<IG>1

<Z>

[Note]

1. It is not necessary to use this command in usual printing operation.
2. Selected sensor type is still in effect after turning off the printer.
3. Do not change the sensor type while printing. Doing so may disable the sensor.

13.11 System

Printer Type		ESC+PM	
HEX code	ESC <1B> ₁₆	PM <50> ₁₆ <4D> ₁₆	Parameter a
Initial value	a=7		

Validity and valid duration of command	When the power switch is off	The set parameter is maintained.
	Validity in a job	The set parameter is valid until a new command is specified.
	Validity after a job	The set parameter is valid until a new command is specified.

[Function]

Specifies print mode temporarily.

[Format]

<PM>a

●Parameter

a	[Printer type]	=	0	:	Continuous
			1	:	Tear off
			7	:	Dispenser (Thermal head position)
			8	:	Dispenser (Dispensing position)

[Example]

<A>

<PM>0

<Z>

[Note]

1. Description of each mode :

(0) Continuous

No printer action after printing the label.

(1) Tear-off

When the next print data is not received within a specified time, the label is fed to the tear off position. Then the printer, after receiving the next print data, feeds the label back to the thermal head position.

(7) Dispenser (Thermal head position)

The printer feeds the label back to the thermal head position after the last label is dispensed.

(8) Dispenser (Dispensing position)

The printer, after receiving the print data, feeds the label back to the thermal head position. Then the printer feeds the printed label to the dispensing position.

13.12 System

Offset		ESC+PO	
HEX code	ESC <1B> ₁₆	PO <50> ₁₆ <4F> ₁₆	Parameter abcc
Initial value	a=0, b=+, c=00		

Validity and valid duration of command	When the power switch is off	The set parameter is not maintained.
	Validity in a job	The set parameter is valid until a new command is specified.
	Validity after a job	The set parameter is valid until a new command is specified.

[Function]

Adjusts the label stop position temporarily in each mode.

[Format]

<PO>abcc

• Parameter

a	[Offset]	= 1 : Dispenser 2 : Tear off 3 : Continuous
b	[Offset direction]	= + : Forward feed direction - : Backward feed
c	[Offset volume]	= 00 to 99 dots

[Example]

<A>

<PO>1+08

<Z>

[Note]

1. It is not necessary to use this command in usual printing operation.
2. Specify this command at the time of a misalignment error.

13.13 System

Waiting Time for Tear-off

ESC+TW

HEX code	ESC	TW	Parameter
	<1B> ₁₆	<54> ₁₆ <57> ₁₆	aaa
Initial value	aaa = 010(1000ms)		

Validity and valid duration of command	When the power switch is off	The set parameter is maintained.
	Validity in a job	The set parameter is valid until a new command is specified.
	Validity after a job	The set parameter is valid until a new command is specified.

[Function]

Sets the waiting time for tear-off motion.

[Format]

<TW>aaa

- Parameter

aaa [Waiting time for tear-off] = 005 to 200 (by 100ms)

[Example] (Waiting time for tear-off = 1.5 seconds)

<A>

<TW>015

<Z>

[Note]

1. After completing the print job in Tear-off mode, the printer waits before starting tear-off motion. This waiting time from the completion of print job to the start of tear-off motion can be set by the Waiting Time for Tear-off <TW> command.
2. The value set by this command will be effective immediately after sending the command, and its setting value will be in effect after turning off the printer.

13.14 System

Forced Tear-off Motion

ESC+TK

HEX code	ESC	TK	Parameter
	<1B> ₁₆	<54> ₁₆ <4B> ₁₆	None
Initial value	None		

Validity and valid duration of command	When the power switch is off	The set parameter is maintained.
	Validity in a job	The set parameter is valid until a new command is specified.
	Validity after a job	The set parameter is valid until a new command is specified.

[Function]

Executes forced tear-off motion.

[Format]

<TK>

[Example]

<A>

<TK>

<Z>

[Note]

1. This command is available only when the printer is started in Tear-off mode.
2. Tear-off motion can be executed without waiting time specified by the Waiting Time for Tear-off <TW> command. Even when the next print data is received before tear-off motion, forced tear-off motion will be executed.
3. This command cannot be used in combination with other commands related to printing. Send this command solely.

[Tip]

1. When not having the next job for sure, it is possible to use this command to save on the printing duration which is equivalent to the waiting time for tear-off.

13.15 System			
Mincho-Type Kanji			ESC+KM
HEX code	ESC	KM	Parameter
	<1B> ₁₆	<4B> ₁₆ <4D> ₁₆	None
Initial value	None		
Validity and valid duration of command	When the power switch is off	The set parameter is not maintained.	
	Validity in a job	The set parameter is valid until a new command is specified.	
	Validity after a job	The set parameter is valid until a new command is specified.	

[Function]

Sets the Kanji font to Mincho-type.

[Format]

<KM>

[Example]

```

<A>
<KM>
<V>100<H>200<P>2<L>0304
<K1>H82508A94816A83548367815B
<KG>
<V>200<H>200<P>2<L>0304
<K1>H82508A94816A83548367815B
<Q>2
<Z>

```

[Note]

1. This command can be used more than once within a job.
2. The initial value is Gothic-type Kanji.
3. This command is effective only when NEC Kanji font has been installed in the printer. For the printer with Ryobi font, the execution of this command neither causes an error nor changes the printer setting.

13.16 System			
Gothic-Type Kanji			ESC+KG
HEX code	ESC	KG	Parameter
	<1B> ₁₆	<4B> ₁₆ <47> ₁₆	None
Initial value	See the table below		
Validity and valid duration of command	When the power switch is off	The set parameter is not maintained.	
	Validity in a job	The set parameter is valid until a new command is specified.	
	Validity after a job	The set parameter is valid until a new command is specified.	

[Function]

Sets the Kanji font to Gothic-type.

[Format]

<KG>

[Example]

<A>

<KG>

<V>100<H>200<P>2<L>0304

<K1>H82508A94816A83548367815B

<KM>

<V>200<H>200<P>2<L>0304

<K1>H82508A94816A83548367815B

<Q>2

<Z>

[Note]

1. This command can be used more than once within a job.
2. The initial value is Gothic-type Kanji.
3. This command is effective only when NEC Kanji font has been installed in the printer. For the printer with Ryobi font, the execution of this command neither causes an error nor changes the printer setting.

14. Memory Card Commands

14.1 Memory Card			
Card Slot			ESC+CC
HEX code	ESC	CC	Parameter
	<1B> ₁₆	<43> ₁₆ <43> ₁₆	a
Initial value	a=0		
Validity and valid duration of command	When the power switch is off	The set parameter is not maintained.	
	Validity in a job	The set parameter is valid until a new command is specified.	
	Validity after a job	The set parameter is valid until a new command is specified.	

[Function]

Specifies the card slot number to be used.

[Format]

<CC>a

•Parameter

a [Slot number] = 1 : Card slot (SD card)
2 : Flash ROM

[Example]

<A>

<CC>1

<GI>H003003001FF000000~000000FF

<Z>

[Note]

1. Be sure to specify this command when sending the command to a memory card.
2. When the card is not inserted in the slot, it will cause a card error.
3. It may take a while to access the Flash ROM. Make sure the printer status is back to [Analyzing/Editing], [No error (Offline state)] or [Standby (Online state)] by status request. Then perform the next operation (e.g. Turning off the power).
4. Setting the value other than the above to the parameter causes a parameter error.

14.2 Memory Card

Format Memory Card		ESC+FM	
HEX code	ESC <1B> ₁₆	FM <46> ₁₆ <4D> ₁₆	Parameter (aaaaaaaa)
Initial value	None		
Validity and valid duration of command	When the power switch is off	The set parameter is not maintained.	
	Validity in a job	The set parameter becomes invalid.	
	Validity after a job	The set parameter becomes invalid.	

[Function]

Specifies the format (initialization) of memory card.

[Format]

<FM>(aaaaaaaa)

- Parameter

a [User ID]

= Up to 8 bytes of arbitrary alphanumeric and symbols

* This is omissible when the card slot (SD card) is selected by the Card Slot <CC> command.

[Example]

<A>

<CC>1

<FM>SATO

<Z>

[Note]

1. Make sure to specify the card slot number specified with the Card Slot <CC> command before this command.
2. This command is used for formatting the memory card and cannot be used in combination with other commands except the Card Slot <CC> command.
3. If formatting a memory card by accident, registered data will be erased. We cannot be held liable for any damages or losses of stored contents.
4. It may take some time to format the memory card. Do not issue any commands while formatting the memory card.
5. When the card slot (SD card) is specified by the Card Slot <CC> command for formatting the SD card, all the stored data in the SD card will be deleted, and then the folder configuration which is necessary for this printer will be created.

14.3 Memory Card

Print Memory Card Status		ESC+FP	
---------------------------------	--	---------------	--

HEX code	ESC	BJS	Parameter
	<1B> ₁₆	<46> ₁₆ <50> ₁₆	None
Initial value	None		

Validity and valid duration of command	When the power switch is off	The set parameter is not maintained.
	Validity in a job	The set parameter becomes invalid.
	Validity after a job	The set parameter becomes invalid.

[Function]

Prints out the status of memory card.

[Format]

<FP>

[Example]

<A>
<CC>1
<FP>
<Z>

[Note]

1. Make sure to specify the card slot number specified with the Card Slot <CC> command before this command.
2. This command is for printing the memory card status and cannot be used in combination with other commands.
3. Use the label of W56mm and H80mm to print out and confirm the memory card status.

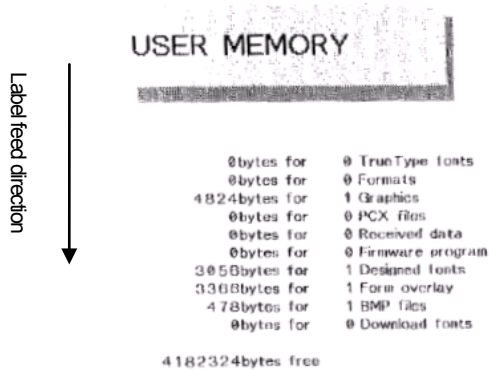

14.4 Memory Card

Store Form Overlay		ESC+&S	
HEX code	ESC <1B> ₁₆	&S <26> ₁₆ <53> ₁₆	Parameter ,aa(,bbbb,cccc)
Initial value	None		

Validity and valid duration of command	When the power switch is off	The stored data becomes valid.
	Validity in a job	The stored data is valid until a new command is specified.
	Validity after a job	The stored data is valid until a new command is specified.

[Function]

Stores fixed print contents to the memory card.

[Format]

<&S>,aa(,bbbb,cccc)

• Parameter

- a [Store number] = 1 to 99
- b [Horizontal size of window] = See the table below (Omissible)
- c [Vertical size of window] = See the table below (Omissible)

[Example]

```
<A>
<V>100<H>100<X21>,MODEL
<CC>1
<&S>,1
<Z>
```

[Note]

- The Card Slot <CC> command must be sent prior to this command.
- Place the format to be stored between the Start Code <A> and the Stop Code <Z> commands.
- Registration of identical store number is invalid.
- The data of Graphics<G> and BMP File <GM> can be stored.
- This command allows up to 99 registries. Note that the capacity of registry may vary depending on the memory card to be used.
- The data stored by this command are cleared by the Clear <*>R command.

[Valid range]

Printer model	Valid range in dots	
	Horizontal size of window	Vertical size of window
HR212	1 to 672	1 to 1200
HR224	1 to 1344	1 to 2400

[Valid commands]

Print position	<V>	<H>								
Font	<X20>	<X21>	<X22>	<X23>	<X24>	<K1>	<K2>	<K3>	<K4>	<K5>
	<K8>	<K9>	<k1>	<k2>	<k3>	<k4>	<k5>	<k8>	<k9>	<\$=>
	<OA>	<OB>								
Barcode		<BC>	<BG>	<BI>	<BZ>	<D>	<D><d>	<BD>	<BT>	<BW>
	<BF>	<BL>	<BL><d>	<BM>						
2D code	<2D10>	<2D12>	<2D20>	<2D30>	<2D31>	<2D32>	<2D33>	<2D50>		
Composite symbol	<EU>									
Modification	<WD>	<FW>	</>	<RF>						
Graphic	<G>	<GM>	<GP>							

In general, this command is used for [Store number] only. By specifying the horizontal and vertical window sizes, the label image can be moved by using the <V> and <H> position commands when recalling the label image. If the repositioned label image exceeds the printable area, the image will be truncated.

See the following examples.

(1) Normal operation (Registration)

```
<A>
<V>100<H>100<P>2<L>0202
<X22>,ABCD
<V>60<H>60
<FW>0808V800H400
<V>320<H>60
<FW>04H400
<CC>1
<&S>.1
<Z>
```

Stored label image

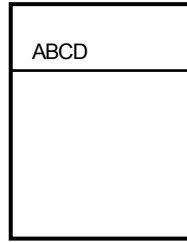

(2) When print is specified after the <&S> command.

```
<A>
<V>100<H>100<P>2<L>0202
<X22>,ABCD
<V>60<H>60
<FW>0808V800H400
<V>320<H>60
<FW>04H400
<CC>1
<&S>.1
<V>200<H>100<OB>12345
<Z>
```

Anything specified prior to the <&S> command is stored as form overlay

← Prints

(3) When window size is specified.

Media size specification <A1>800400

Horizontal size of window: 200

Vertical size of window: 200

```
<A>
<A1>800400
<V>100<H>100<P>2<L>0202
<X22>,ABCD
<CC>1
<&S>.1,200,200
<Z>
```

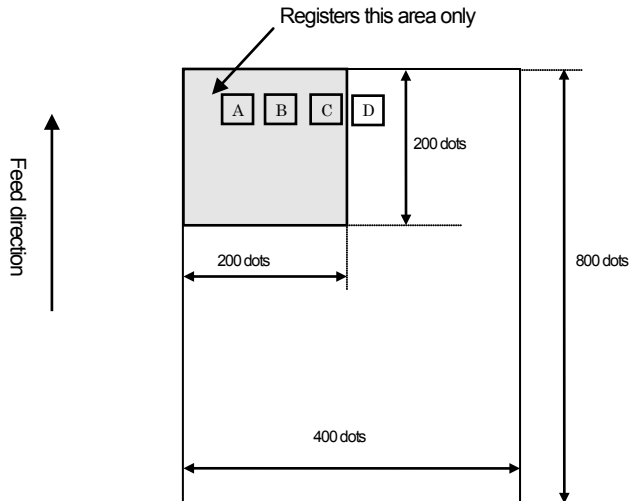

14.5 Memory Card

Recall Form Overlay		ESC+&R	
----------------------------	--	-------------------	--

HEX code	ESC <1B> ₁₆	&R <26> ₁₆ <52> ₁₆	Parameter ,aa
Initial value	None		

Validity and valid duration of command	When the power switch is off	The set parameter is not maintained.
	Validity in a job	The set parameter becomes invalid.
	Validity after a job	The set parameter becomes invalid.

[Function]

Recalls the data stored by the Store Form Overlay <&S> command.

[Format]

<&R>,aa

• Parameter

a [Registration number] = 1 to 99

[Example]

<A>
<CC>1
<&R>1
<Q>2
<Z>

[Note]

1. The Card Slot <CC> command must be sent prior to this command.
2. Several images stored under different registration numbers can be printed with this command.
3. If a registration number is not specified, this command will be ignored.
4. A read/write error will occur if an unused registration number is specified.
5. If a label image is stored without specifying a window size, the <V> and <H> position commands will be ignored, and V1 and H1 (start position of drawing area) will be determined.
6. A label image can be moved by using the <V> and <H> position commands when it is stored along with a window size. If it exceeds the printable area by being moved, the label image will be truncated.

14.6 Memory Card

Store Format			ESC+YS
HEX code	ESC <1B> ₁₆	YS <59> ₁₆ <53> ₁₆	Parameter ,aaa
Initial value	None		

Validity and valid duration of command	When the power switch is off	The set parameter is not maintained.
	Validity in a job	The set parameter is valid until a new command is specified.
	Validity after a job	The set parameter is valid until a new command is specified.

[Function]

Stores a format field description.

[Format]

<YS>,aaa

• Parameter

a [Format number to be stored] = 1 to 999

[Example]

<A>

<CC>1

<YS>1

</N>,3,3

<%>0<V>100<H>200<P>2<L>0101<X22>,ABC

<Z>

[Note]

1. When storing multiple formats, enter the Start Code <A> and the Stop Code <Z> commands with one format.
2. The Card Slot <CC> command must be sent prior to this command.
3. Use this command in conjunction with the Store Field command </N>.
4. Attempts to store using a predefined field number will result in an error and the targeted content will be printed.

[Registerable commands]

Print position	<V>	<H>								
Font	<X20>	<X21>	<X22>	<X23>	<X24>	<K1>	<K2>	<K3>	<K4>	<K5>
	<K8>	<K9>	<k1>	<k2>	<k3>	<k4>	<k5>	<k8>	<k9>	<\$=>
	<OA>	<OB>								
Barcode		<BC>	<BG>	<BI>	<BZ>	<D>	<D><d>	<BD>	<BT>	<BW>
Modification	<WD>	<FW>	</>							
System	<A1>	<A3>								
Memory card	<&R>	</N>	<GR>	<GC>						

[Tip]

1. Details on the registration of format

A group of commands can be registered to a memory card. Once registered, it saves time to specify the identical command group. The registration also allows a change of print data when recalling the format. Such function is called "Registration of Format".

One item consists of different command groups necessary for printing, and such groups are called "Field". Note that multiple fields make format.

Commands for the registration of format.

One format consists of a set of commands from the Start Code <A> command to the Stop Code command <Z>, and specify the Store Format <YS> command right after the <A> command. For the <YS> command, specify [Format number to be stored] between 1 and 999. And then, insert the Store Field <N> command after the <YS> command to specify [Field number] and [Print digit number].

After [Field number] and [Print digit number] are entered, specify print position, character type, barcode, and so on.

[Registration Example]

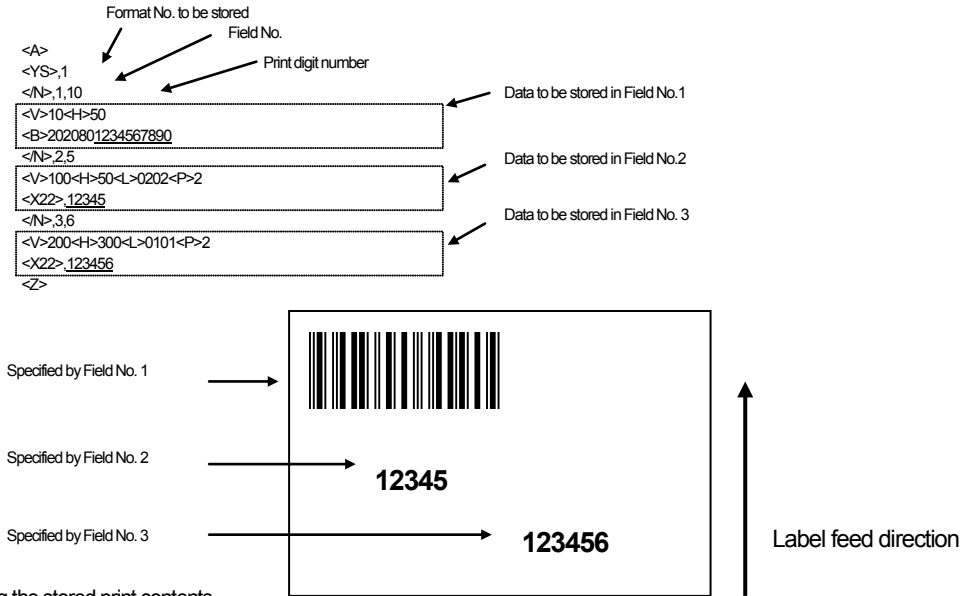

Recalling the stored print contents.

Stored formats from 1 to 999 can be specified by the Recall Format <YR> command.

To change print data, use the Print Field <D> command to specify [Field No.] to be changed, and continuously specify the changed print data.

Note that the underlined part in the [Registration Example] is changeable.

[Call Example]

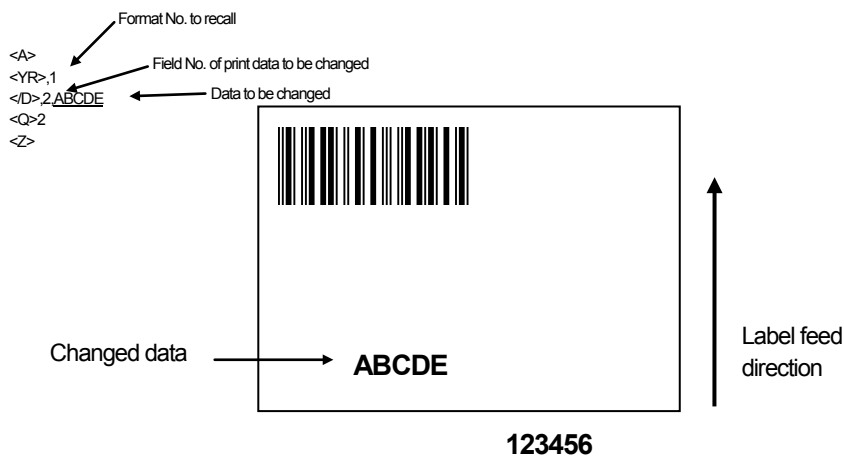

The followings are the invalid commands for storing formats.

Category	Command	Command name
Control	<Q>	Print Quantity
	<ID>	Job Store ID
	<WK>	Job Name
Modification	<&>	Store Form Overlay
	<F>	Sequential Numbering
	<0>	Replace Data (Partial Edit)
Font	<T1>	Store 16 x 16 dots External Character
	<T2>	Store 24 x 24 dots External Character
Barcode	<BT>	Variable Ratio Barcodes
2D code	<2D10>	PDF417
	<2D12>	Micro PDF
	<2D20>	MAXI Code
	<2D30>	QR Code (Model 2)
	<2D31>	QR Code (Model 1)
	<2D32>	Micro QR Code
	<2D33>	SRQC Code
Graphic	<G>	Custom Graphic
	<GM>	BMP File
System	<CS>	Print Speed
	<#E>	Print Darkness
	<C>	Repeat Label
	<^>	Clear
	<@>	Offline
Memory card	<FM>	Format Memory Card
	<G>	Store Graphic
	<GT>	Store BMP File
	<D>	Print Field
	<FP>	Print Memory Card Status
	<T1>	Store 16 x 16 Dots External Character
<T2>	Store 24 x 24 Dots External Character	

14.7 Memory Card

Store Field				ESC+/N
HEX code	ESC <1B> ₁₆	/N <2F> ₁₆ <4E> ₁₆	Parameter ,aa,bb	
Initial value	None			

Validity and valid duration of command	When the power switch is off	The set parameter is not maintained.
	Validity in a job	The set parameter is valid until a new command is specified.
	Validity after a job	The set parameter is valid until a new command is specified.

[Function]

Stores a format field description in the Store Format <YS> command.

[Format]

<N>,aa,bb

•Parameter

a [Field number] = 1 to 99
b [Print digit number] = 1 to 99

[Example]

```
<A>
<CC>1
<YS>.01
<N>1,3
<%>0<V>100<H>200<P>2<L>0101<X22>,ABC
<N>2,5
<%>0<V>200<H>200<P>2<L>0101<OA>12345
<N>3,8
<%>0<V>300<H>40<B>40208049123456
<Z>
```

[Note]

- Specify the field number in ascending order.
- Specify the <V> and <H> position commands for each field. If not, the initial value will be set.
- Specification of digit number when printing external characters.
For an external character code "H", 1 external character has 4 digits; thus, the print of 3 characters need 12 digits.
For an external character code "B", 1 external character has 2 digits; thus, the print of 3 characters need 6 digits.
- Use this command in conjunction with the Store Format <YS> command.
- Due to the memory capacity limit, it may not save up to 99 registries.
- The Card Slot <CC> command must be sent prior to this command.

[Valid commands for the change of print]

Font	<X20>	<X21>	<X22>	<X23>	<X24>	<K1>	<K2>	<K3>	<K4>	<K5>
	<K8>	<K9>	<k1>	<k2>	<k3>	<k4>	<k5>	<k8>	<k9>	<\$=>
	<OA>	<OB>								
Barcode		<BC>	<BG>	<BI>	<BZ>	<D>	<D><d>	<BD>	<BT>	<BW>

14.8 Memory Card			
Recall Format			ESC+YR
HEX code	ESC	YR	Parameter
	<1B> ₁₆	<59> ₁₆ <52> ₁₆	,aaa
Initial value	None		
Validity and valid duration of command	When the power switch is off	The set parameter is not maintained.	
	Validity in a job	The set parameter is valid until a new command is specified.	
	Validity after a job	The set parameter is valid until a new command is specified.	

[Function]

Recalls and prints out the format stored by the Store Format <YS> command.

[Format]

<YR>,aaa

•Parameter

a [Format registration] = 1 to 999

[Example]

```

<A>
<CC>1
<YR>01
</D>,1,DEF
</D>,2,78901
</D>,3,49000238
<Q>2
<Z>

```

[Note]

1. The Recall Format <YR> command cannot recall multiple formats between the Start Code <A> and the Stop Code <Z> commands.
2. Use this command in conjunction with the Print Field </D> command.
3. The Card Slot <CC> command must be sent prior to this command.

14.9 Memory Card

Print Field		ESC+/D	
HEX code	ESC <1B> ₁₆	/D <2F> ₁₆ <44> ₁₆	Parameter ,aa,n~n
Initial value	None		
Validity and valid duration of command	When the power switch is off	The set parameter is not maintained.	
	Validity in a job	The set parameter is valid until a new command is specified.	
	Validity after a job	The set parameter is valid until a new command is specified.	

[Function]

Recalls the field specified by the Store Field </N> command and selects the data.

[Format]

</D>,aa,n~n

•Parameter

a [Field No.] = 1 to 99
n [Data] = Data to be changed

[Example]

```
<A>
<CC>1
<YR>,01
</D>1,DEF
</D>2,78901
</D>3,49000238
<Q>2
<Z>
```

[Note]

1. Print digit number is valid within the Store Field </N> command.
2. When digit number of this command is longer than the one specified with the Store Field </N> command, only the defined digit number will be available for printing.
3. Use this command in conjunction with the Recall Format <YR> command.
4. The Card Slot <CC> command must be sent prior to this command.

14.10 Memory Card

Store Graphic		ESC+GI	
HEX code	ESC <1B> ₁₆	GI <47> ₁₆ <49> ₁₆	Parameter abbbccddn~n
Initial value	None		

Validity and valid duration of command	When the power switch is off	The set parameter is not maintained.
	Validity in a job	The set parameter becomes invalid.
	Validity after a job	The set parameter becomes invalid.

[Function]

Stores the graphic pattern data.

[Format]

<GI>abbbccddn~n

• Parameter

- | | | |
|---|--|--------------------------------|
| a | [Selects and sends Hexadecimal or Binary data] | = H : HEX data
B : BIN data |
| | HEX data (8 bits data is divided into 4 bits, and outputs as a HEX code corresponding to ASCII.) | |
| | Binary data (Outputs 8 bits as 1 character data is all at once) | |
| b | [Specifies the horizontal graphic area in byte] | = See the table below |
| c | [Specifies the vertical graphic area in byte] | = See the table below |
| d | [Registration number] (identification number when recalling) | = 1 to 999 |
| n | [Data] | = Graphic data |

[Example]

```
<A>
<CC>1
<GI>H003003001n~n
<Z>
```

[Note]

- Specify the storage data only.
- To change the stored content, clear it with the Clear <*> command and store it again.
- The data stored with this command can be printed with the Recall Graphic <GR> command.
- If the graphic data is not stored properly, a print error may occur. Refer to the Custom Graphics <G> command for the data form.
- Attempts to store using a predefined registration number will result in an error and the targeted content will be printed.
- The Card Slot <CC> command must be sent prior to this command.

[Valid range]

Printer model	Max. bytes in crosswise direction	Max. bytes in lengthwise direction
HR212	56	200
HR224	112	400

14.11 Memory Card

Recall Graphic		ESC+GR	
HEX code	ESC <1B> ₁₆	GR <47> ₁₆ <52> ₁₆	Parameter aaa
Initial value	None		

Validity and valid duration of command	When the power switch is off	The set parameter is not maintained.
	Validity in a job	The set parameter becomes invalid.
	Validity after a job	The set parameter becomes invalid.

[Function]

Recalls and prints the graphic image stored by the Store Graphic <GI> command.

[Format]

<GR>aaa

- Parameter

a [Registration number] = 1 to 999

[Example]

<A>

<V>100<H>100

<CC>1

<GR>1

<Q>1

<Z>

[Note]

1. The Start Point Correction <A3> command will be ignored.
2. The Rotate <%> and the Character Expansion <L> commands can be used for the recalled graphic image.
3. The Character Expansion <L> command must be sent right before this command.
4. Place the Rotation <%> command followed by the Character Expansion <L> command when using with this <GR> command.
5. The Card Slot <CC> command must be sent prior to this command.

14.12 Memory Card

Store BMP File		ESC+GT	
HEX code	ESC <1B> ₁₆	GT <47> ₁₆ <54> ₁₆	Parameter aaa,bbbb,n~n
Initial value	None		
Validity and valid duration of command	When the power switch is off	The set parameter is not maintained.	
	Validity in a job	The set parameter becomes invalid.	
	Validity after a job	The set parameter becomes invalid.	

[Function]

Stores a graphic file in BMP format.

[Format]

<GT>aaa,bbbb,n~n

• Parameter

- a [Registration number] = 1 to 999
- b [Size of BMP file in bytes] = 1 to 99999
Specify the BMP file size for total bytes.
- n [Data] = BMP file data
Send binary data (outputs 8 bits as 1 font data).

[Example]

```
<A>
<CC>1
<GT>1.12345.n~n
<Z>
```

[Note]

1. Data must be sent in binary format (outputs 8 bits as 1 font data). (BMP file size is the total bytes, BMP file data is the data)
2. The first 62 bytes of the BMP file is used for the header and the remainder is the BMP image data.
3. If the total bytes of BMP file does not match the transfer data, an error may occur.
4. Total bytes is the file size indicated in the properties.
5. Only black and white non-compressed BMP files can be stored. Color BMP files cause a command error. Make sure to check the file extension is [BMP] before printing.
6. The Card Slot <CC> command must be sent prior to this command.
7. Reregistering data with registration number which was already taken will cause an error, but the reregistered data will be printed.

14.13 Memory Card

Recall BMP File	ESC+GC
------------------------	---------------

HEX code	ESC	GC	Parameter
	<1B> ₁₆	<47> ₁₆ <43> ₁₆	aaa
Initial value	None		

Validity and valid duration of command	When the power switch is off	The set parameter is not maintained.
	Validity in a job	The set parameter becomes invalid.
	Validity after a job	The set parameter becomes invalid.

[Function]

Recalls and prints out a graphic file previously stored by the Store BMP File <GT> command.

[Format]

<GC>aaa

- Parameter

a [Registration number] = 1 to 999

[Example]

<A>

<V>100<H>100

<CC>1

<GC>1

<Q>2

<Z>

[Note]

1. The Rotate <%> and the Character Expansion <L> commands can be used for the recalled graphic file.
2. The Character Expansion <L> command must be sent right before this command.
3. Place the Rotation <%> command followed by the Character Expansion <L> command when using with this <GC> command.
4. The Card Slot <CC> command must be sent prior to this command.

14.14 Memory Card

Store 16 x 16 Dots External Character to Memory Card		ESC+T1	
HEX code	ESC <1B> ₁₆	T1 <54> ₁₆ <31> ₁₆	Parameter abbn~n
Initial value	None		

Validity and valid duration of command	When the power switch is off	The set parameter is not maintained.
	Validity in a job	The set parameter becomes invalid.
	Validity after a job	The set parameter becomes invalid.

[Function]

Saves external character in W16 x H16 dots to memory card.

[Format]

<T1>abbn~n

• Parameter

- a [Selection of registered data type] = H: Registered data in hexadecimal character
= B: Registered data in binary code
- b [Registered font code address] <JIS code specification>
H: Within the range from 21 to 7F, up to 95 entries.
B: Within the range from 21H to 7FH, up to 95 entries.
<Shift JIS specification>
H: Within the range from 40 to 9E, up to 95 entries.
B: Within the range from 40H to 9EH, up to 95 entries.
<Unicode>
H: Within the range from 00 to 5E, up to 95 entries.
B: Within the range from 00H to 5EH, up to 95 entries.
- n [External character registered data]

[Example]

```
<A>
<CC>1
<T1>H2100FF00FF~3C0000FF
<Q>2
<Z>
```

[Note]

- It is possible to rewrite the registered data.
- The Card Slot <CC> command must be sent prior to this command.
- Sending this command together with other registration commands may cause an error due to out of memory card space.
- Data output order is as follows.

External character file [16x16]

D 1	D 2
D 3	D 4
D 5	D 6
D 3 1	D 3 2

14.15 Memory Card

Store 24 x 24 Dots External Character to Memory Card		ESC+T2	
HEX code	ESC <1B> ₁₆	T2 <54> ₁₆ <32> ₁₆	Parameter abbn~n
Initial value	None		

Validity and valid duration of command	When the power switch is off	The set parameter is not maintained.
	Validity in a job	The set parameter becomes invalid.
	Validity after a job	The set parameter becomes invalid.

[Function]

Saves external character in W24 x H24 dots to memory card.

[Format]

<T2>abbn~n

• Parameter

- a [Selection of registered data type] = H: Registered data in hexadecimal character
= B: Registered data in binary code
- b [Registered font code address] <JIS code specification>
H: Within the range from 21 to 7F, up to 95 entries.
B: Within the range from 21H to 7FH, up to 95 entries.
<Shift JIS specification>
H: Within the range from 40 to 9E, up to 95 entries.
B: Within the range from 40H to 9EH, up to 95 entries.
<Unicode>
H: Within the range from 00 to 5E, up to 95 entries.
B: Within the range from 00H to 5EH, up to 95 entries.
- n [External character registered data]

[Example]

```
<A>
<CC>1
<T2>H2100FF00FF~3C0000FF
<Q>2
<Z>
```

[Note]

- It is possible to rewrite the registered data.
- The Card Slot <CC> command must be sent prior to this command.
- Sending this command together with other registration commands may cause an error due to out of memory card space.
- Data output order is as follows.

External character file [24x24]

D 1	D 2	D 3
D 4	D 5	D 6
D 7	D 8	D 9
D 7 0	D 7 1	D 7 2

14.16 Memory Card

Call Horizontal Flow External Chr. Stored in Memory Card

ESC+K1(K2)

HEX code	ESC	K1	Parameter
	<1B> ₁₆	<4B> ₁₆ <31> ₁₆	an~n
Initial value	None		

Validity and valid duration of command	When the power switch is off	The set parameter is not maintained.
	Validity in a job	The set parameter becomes invalid.
	Validity after a job	The set parameter becomes invalid.

[Function]

Calls external characters stored in memory card.

[Format]

<K1>an~n

<K2>an~n

• Parameter

a [Registration of external character]

= H: Hexadecimal character

B: Binary code

I: Smoothing function by Hexadecimal character

C: Smoothing function by Binary code

J: Highlighting function by Hexadecimal character

D: Highlighting function by Binary code

K: Smoothing and highlighting functions by Hexadecimal character

E: Smoothing and highlighting functions by Binary code

n [Registration code]

= <JIS code specification>

H, I, J, K : "9021" to "907F"

B, C, D, E : 9021H to 907FH

<Shift JIS code specification>

H, I, J, K : "F040" to "F09E"

B, C, D, E : F040H to F09EH

<Unicode>

H, I, J, K : "E000" to "E05E"

B, C, D, E : E000H to E05EH

[Example]

<A>

<V>100<H>100

<CC>1

<K1>H9021

<Q>2

<Z>

[Note]

1. The Card Slot <CC> command must be sent prior to this command.
2. External characters stored by JIS and Shift JIS cannot be recalled by Unicode. Also, the external characters stored by Unicode cannot be recalled by JIS and Shift JIS.

14.17 Memory Card

Call Vertical Flow External Chr. Stored in Memory Card		ESC+k1(k2)	
HEX code	ESC	k1(k2)	Parameter
	<1B> ₁₆	<6B> ₁₆ <31> ₁₆ (<6B> ₁₆ <32> ₁₆)	an~n
Initial value	None		

Validity and valid duration of command	When the power switch is off	The set parameter is not maintained.
	Validity in a job	The set parameter becomes invalid.
	Validity after a job	The set parameter becomes invalid.

[Function]

Calls external characters stored in memory card.

[Format]

<k1>an~n

<k2>an~n

• Parameter

a [Registration of external character]

= H: Hexadecimal character

B: Binary code

I: Smoothing function by hexadecimal character

C: Smoothing function by binary code

J: Highlighting function by hexadecimal character

D: Highlighting function by binary code

K: Smoothing and highlighting functions by hexadecimal character

E: Smoothing and highlighting functions by binary code

n [Registration code]

= <JIS code specification>

H, I, J, K : "9021" to "907F"

B, C, D, E : 9021H to 907FH

<Shift JIS code specification>

H, I, J, K : "F040" to "F09E"

B, C, D, E : F040H to F09EH

<Unicode>

H, I, J, K : "E000" to "E05E"

B, C, D, E : E000H to E05EH

[Example]

<A>

<V>100<H>100

<CC>1

<k1>H9021

<Q>2

<Z>

[Note]

1. The Card Slot <CC> command must be sent prior to this command.
2. External characters stored by JIS and Shift JIS cannot be recalled by Unicode. Also, the external characters stored by Unicode cannot be recalled by JIS and Shift JIS.

14.18 Memory Card

Clear (Memory Card)		ESC+*	
HEX code	ESC	*	Parameter
	<1B> ₁₆	<2A> ₁₆	a(,bbb)
Initial value	None		

Validity and valid duration of command	When the power switch is off	The set parameter is not maintained.
	Validity in a job	The set parameter becomes invalid.
	Validity after a job	The set parameter becomes invalid.

[Function]

Clears the entire contents in memory card.

[Format]

<*>a

- Parameter
a [Item to be cleared] = T : Registration of external character
Clearing all the external characters registered with <T1> and <T2> commands.

[Format]

<*>a(,bbb)

- Parameter
a [Item to be cleared] = G : SATO Graphic
(Clearing graphic registered with Store Graphic <GI>)
M : BMP file
(Clearing BMP file registered with Store BMP File <GT>)
F : Format
(Clearing format registered with Store Format <YS>)
R : Form Overlay
(Clearing form overlay registered with Store Form Overlay <&S>)
- b [Registration number] = 001 to 999 (Omissible)
(When omitting [Registration number], all the registered data are cleared.)

[Example 1] Clearing registered external character data

```
<A>
<CC>1
<*>I
<Z>
```

[Example 2] Clearing SATO graphic "001"

```
<A>
<CC>1
<*>G,001
<Z>
```

[Example 3] Clearing all the BMP files

```
<A>
<CC>1
<*>M
<Z>
```

[Example 4] Clearing format "001"

```
<A>
<CC>1
<*>F,001
<Z>
```

[Example 5] Clearing the entire form overlay

```
<A>
<CC>1
<*>R
<Z>
```

[Note]

1. Place this command between the Start Code <A> and the Stop Code <Z> commands.
2. The Card Slot <CC> command must be sent prior to this command.

[Tip]

1. To delete all data stored in memory card, use the Format Memory Card <FM> command.

15. Extended Function

15.1 Extended Function

Media Feed Control		ESC+IK	
--------------------	--	--------	--

HEX code	ESC	IK	Parameter
	<1B> ₁₆	<49> ₁₆ <4B> ₁₆	a(.bbbb)
Initial value	None		

Validity and valid duration of command	When the power switch is off	The set parameter is not maintained.
	Validity in a job	The set parameter becomes invalid.
	Validity after a job	The set parameter becomes invalid.

[Function]
Feeds the label forward or backward based on the specified length.

[Format]
<IK>a,bbbb
 •Parameter
 a [Feed direction] = 0: Forward feed
 1: Backward feed
 b [Feed distance] = See the table on the next page (The parameter for forward feed is omissible)
 The printer feeds one label when omitting this parameter.

[Example 1] Forward feed for 120 dots

<A>
<IK>0,120
 <Z>

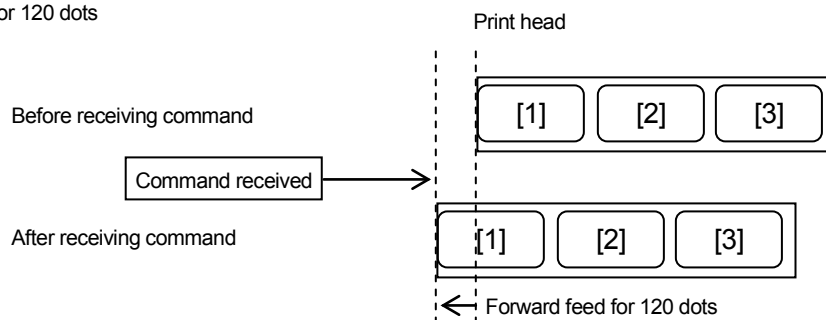

When the printer receives print data without feeding the label back to the original position by "<IK>1,120", it restarts printing from the current stop position.

[Example 2] Feeding one label

<A>
<IK>0
 <Z>

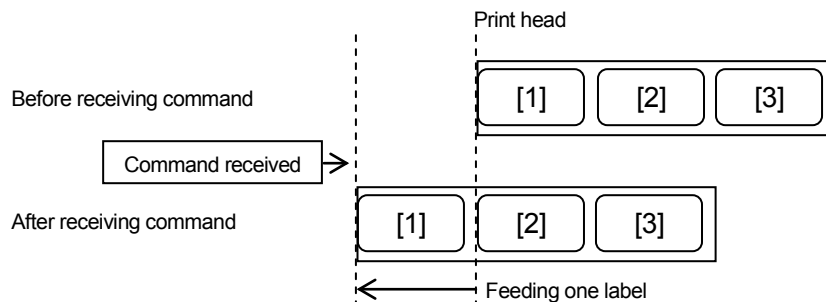

[Note]

1. Place this command between Start code <A> and Stop code <Z>. This command is invalid when specified in the item together with the print data.
2. When the label feed direction is set to backward feed, make sure to perform forward feed beforehand.
3. When the label feed direction is set to backward feed, make sure to set the distance shorter than forward feed. Setting the backward feed distance longer than the forward feed distance may cause errors such as overlapping print and paper end (label slips off the platen), or detect ribbon end by mistake.
4. Do not set the backward feed distance to 48mm or more. Setting this distance longer than 48mm may detect ribbon end by mistake. Do not specify the command for backward feed continuously.
5. Feed speed after specifying the feed distance is fixed to 2 inch/sec.
6. If not specifying the feed distance in a forward feed direction, the printer motion will be the same as that of feed motion when pressing the FEED key in offline state.
7. Label feed motion specified by this command is performed in online state.
8. Label feed motion cannot be controlled an external signal.
9. If not specifying the feed distance in a backward feed direction, the label will not be fed due to a command error.

[Valid range in a forward feed direction]

Head density	Valid range in dots
12dot/mm	12 to 2400
24dot/mm	48 to 4800

[Valid range in a backward feed direction]

Head density	Valid range in dots
12dot/mm	12 to 576
24dot/mm	48 to 1152

15.2 Advanced Function

LCD Display Message		ESC+IM	
----------------------------	--	---------------	--

HEX code	ESC <1B> ₁₆	IM <49> ₁₆ <4D> ₁₆	Parameter a(.bbb···b)
Initial value	None		

Validity and valid duration of command	When the power switch is off	The set parameter is not maintained.
	Validity in a job	The set parameter is valid until a new command is specified.
	Validity after a job	The set parameter is valid until a new command is specified.

[Function]

Specifies the display message indicating the online status in normal mode.
Up to 16-digits of alphanumeric and symbols can be entered for the display message.

[Format]

<IM>a(.bbb···b)

• Parameter

- a [Enable/Disable display message] = 0 : Not displaying a message
1 : Displaying a message on the first row
2 : Displaying a message on the second row
- b [LCD display message] = Display range : Up to 16-digit of alphanumeric and symbols only (ASCII 20H ~ 7EH)
This parameter is omissible when disabling display message.

[Example 1] Changing the LCD display message on the first row

<A>

<IM>1,FORMAT01

Print data

<Q>100

<Z>

Before command reception

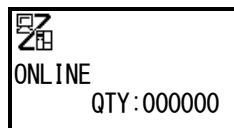

After command reception

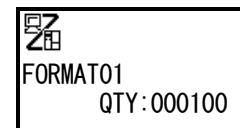

[Example 2] Returning to the previous LCD display message

<A>

<IM>0

<Z>

Before command reception

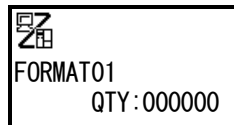

After command reception

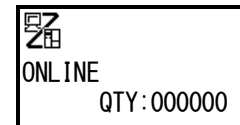

[Note]

- LCD display message goes back to the usual LCD display by turning off the printer.
- If specifying the message exceeding 16 digits, the exceeded digits are not displayed.
- The specified character string is left aligned on the LCD display. When the specified character string is under 16 digits, the lack of digits is covered by "Space" (20H).
- If omitting the display message, the current LCD display message will not be changed.
- Specified message is displayed only in online state under normal mode. When the printer is in offline or error state, the specified message does not appear.
- When undisplayable codes are included in the display message, they will be replaced with space (20H).
- When the control code (00H~1FH) is included in the display message, the printer processes it as control code. Because of this, the printer may not operate correctly. Be sure not to include any control codes in the display message.
- Label print quantity does not appear on the LCD screen by specifying the display message on the second row.

15.3 Advanced Function

Store Internal Buffer		ESC+IF	
HEX code	ESC <1B> ₁₆	IF <49> ₁₆ <46> ₁₆	Parameter aa,bb,cc,(ddd···d)
Initial value	None		

Validity and valid duration of command	When the power switch is off	The set parameter is not maintained.
	Validity in a job	The set parameter is valid until a new command is specified.
	Validity after a job	The set parameter is valid until a new command is specified.

[Function]

Stores specified data to internal buffer.

32-digit data can be stored up to 16-block in the internal buffer (RAM).

The stored data called by the Call Internal Buffer <IB> command can be used as print data.

[Format]

<IF>aa,bb,cc,(ddd···d)

• Parameter

- a [Internal buffer number] = 1 to 16
- b [Input digits] = 1 to 32
- c [Data] = Number of digits specified in [b] (All codes can be specified)
- d [Data item name] = 16-digit alphanumeric and symbols (Omissible)

[Example]

<A>

<IF>1,2,49,DATA1

<IF>2,6,123456,DATA2

<IF>3,4,1234,DATA3

<IF>6,4,0010,QTY

<Z>

Internal buffer			
No.	Item name	Digits	Data contents
01	DATA1	2	49
02	DATA2	6	123456
03	DATA3	4	1234
04		0	
05		0	
06	QTY	4	0010
07		0	
08		0	
09		0	
10		0	
11		0	
12		0	
13		0	
14		0	
15		0	
16		0	

[Note]

- The stored data can be deleted by turning off the printer.
- Omitting [Data item name] does not change [Item name].
- When the number of specified data exceeds the input digits, the specified data are stored to the buffer in order based on the specified input digits. In this case, the specified data beyond the input digits cannot be saved.
Example) <IF>1,5,12345678 → 5-digit data "12345" is stored
- When the number of specified data is smaller than the input digits, the consecutive parameter or the command sequence is processed as input data. This causes an error and the printer does not operate correctly.
Example) <IF>1,5,456,DATA1 → 5-digit data "456,D" is stored and nothing is saved in the item name.
- When the registered internal buffer number is specified, the registered data is over written and stored to the buffer.

15.4 Advanced Function

Call Internal Buffer		ESC+IB	
HEX code	ESC <1B> ₁₆	IB <49> ₁₆ <42> ₁₆	Parameter aa(,aa,aa···)
Initial value	None		

Validity and valid duration of command	When the power switch is off	The set parameter is not maintained.
	Validity in a job	The set parameter becomes invalid.
	Validity after a job	The set parameter becomes invalid.

[Function]

Obtains the stored data in the internal buffer and uses it as print data such as character string or a barcode.

[Format]

<IB>aa(,aa,aa···)

- Parameter
a [Internal buffer number] = 1 to 16
Use commas to data couple.

[Example] Prints out JAN13 using the internal buffer data

Original data

```
<A>
<V>100<H>100
<IB>1,2,3
<BD>304120
<IB>6
<Q>
<Z>
```

Process data

```
<A>
<V>100<H>100
<BD>304120491234561234
<Q>0010<
<Z>
```

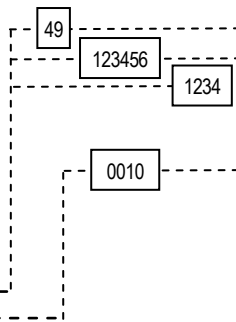

Internal buffer			
No.	Item name	Digits	Data contents
01	DATA1	2	49
02	DATA2	6	123456
03	DATA3	4	1234
04		0	
05		0	
06	QTY	4	0010
07		0	
08		0	
09		0	
10		0	
11		0	
12		0	
13		0	
14		0	
15		0	
16		0	

In the example above, the stored data of the internal buffer 1, 2, and 3 are combined to be used as barcode data.

[Note]

1. The stored data can be deleted by turning off the printer.
2. The commands that can be replaced with print data and parameters are shown in the table on the next page.
3. Specify this command prior to the command that is subject to data replacement.
4. This command is available only when the data or parameter of command that is subject to data replacement is not specified.
When the parameter is specified for the command of data replacement, data will not be replaced with the <IB> command.
5. Internal buffer data can be obtained up to 1024 bytes at a time.
6. The same internal buffer number can be repeatedly specified within the command

List of commands that can be specified for parameter

Category	Command	Command name	Replaceable parameter (Underlined)
Font	<X20>	X20 font	<X20> <u>n~n</u>
	<X21>	X21 font	<X21> <u>n~n</u>
	<X22>	X22 font	<X22> <u>n~n</u>
	<X23>	X23 font	<X23> <u>1n~n</u> * Smoothing enabled (Fixed)
	<X24>	X24 font	<X24> <u>1n~n</u> * Smoothing enabled (Fixed)
	<OA>	OCR-A font	<OA> <u>n~n</u>
	<OB>	OCR-B font	<OB> <u>n~n</u>
	<\$=>	Print outline font	<\$=> <u>n~n</u>
Barcode	<RD>	CG font	<RD>abb,ccc,ddd, <u>n~n</u>
		Barcode (Ratio 1 : 3)	ab cccc <u>n~n</u>
	<D>	Barcode (Ratio 1 : 2)	<D>ab cccc <u>n~n</u>
	<D><d>	Barcode (Selection of HRI)	<D>ab cccc <u>n~n</u> <d> <u>n~n</u>
	<BD>	Barcode (Ratio 2 : 5)	<BD>ab cccc <u>n~n</u>
	<BW>	Print variable ratio barcodes	<BW>a abbbb <u>n~n</u>
	<BI>	UCC/EAN128 for Standard carton ID	<BI>a abbbc <u>n~n</u>
	<BC>	CODE93	<BC>a abbbcc <u>n~n</u>
	<BG>	CODE128	<BG>a abbbb <u>n~n</u>
	<BZ>	Customer Barcode	<BZ> nnnnnnnn , <u>n~n</u>
	<BF>	UPC Add-on barcode	<BF>a abbb <u>n~n</u>
<EU>	EAN, UCC composite symbol	<EU>aabb(ccc) <u>n~n</u>	
2D code	<2D10>	PDF417	<DN>aaaa, <u>n~n</u>
	<2D12>	Micro PDF417	<DN> <u>n~n</u> * Only when binary mode specification is "0 = normal"
	<2D20>	MAXI code	<DN>aaaa, <u>n~n</u>
	<2D30>	QR code (Model 2)	<DS>k, <u>n~n</u> <DN>aaaa, <u>n~n</u>
	<2D31>	QR code (Model 1)	<DS>k, <u>n~n</u> <DN>aaaa, <u>n~n</u>
	<2D32>	Micro QR code	<DS>k, <u>n~n</u> <DN>aaaa, <u>n~n</u>
	<2D33>	SRQC code	<DR>k, <u>n~n</u> <DJ>aaaa, <u>n~n</u> <DS>k, <u>n~n</u> <DN>aaaa, <u>n~n</u>
<2D50>	Data Matrix (ECC200)	<DN>aaaa, <u>n~n</u>	
Control	<Q>	Print quantity	<Q> <u>n~n</u>
Intelligent	<IT>	Data transmission	<IT>aa,bb, <u>n~n</u>

[Important]

When specifying QR code, parameter replacement in the mixed designation of manual mode will be restricted to the cases listed below.

* Mixed number = 1 : Replacing normally.

* Mixed number > 1 : Print data obtained by the <IB> command that was specified prior to the designation of QR code print will be consecutively replaced according to the value of mixed number.

* When replacing the print data with the <IB> command, the use of automatic mode is recommended.

15.6 Advanced Function

Print Internal Buffer Data		ESC+I*	
HEX code	ESC <1B> ₁₆	I* <49> ₁₆ <2A> ₁₆	Parameter None
Initial value	None		

Validity and valid duration of command	When the power switch is off	The set parameter is not maintained.
	Validity in a job	The set parameter becomes invalid.
	Validity after a job	The set parameter becomes invalid.

[Function]

Prints the data stored in the internal buffer on a label.

[Format]

<I*>

[Example]

<A>
<I*>
<Z>

Internal buffer			
No.	Item name	Digits	Data contents
01	DATA1	5	12345
02	DATA2	5	12345
03	DATA3	8	12345678
04		0	
.	.	.	.
.	.	.	.
.	.	.	.
16		0	

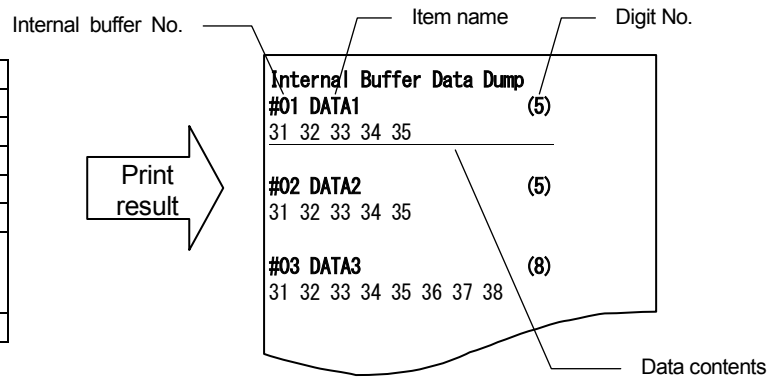

[Note]

1. Place this command between the Start Code <A> command and the Stop Code <Z> command.

15.7 Advanced Function

Exclusive Use of Key		ESC+l#	
HEX code	ESC <1B> ₁₆	l# <49> ₁₆ <23> ₁₆	Parameter a
Initial value	None		
Validity and valid duration of command	When the power switch is off	The set parameter is not maintained.	
	Validity in a job	The set parameter is valid until a new command is specified.	
	Validity after a job	The set parameter is valid until a new command is specified.	

[Function]

Temporarily invalidates routine operator panel key entries and allows operator control.
 When the key is exclusive to the user, all the key entry information will be saved to the key buffer.
 The key entry information is obtainable with the Acquisition of Key Information [SOH+KI] command.

[Format]

<l#>a

• Parameter

a [Initiation / Termination of exclusive key] = 1 : Start
 0 : End

[Example]

```
<A>
<l#>1
<IM>1,PRINT START
<IM>2,PUSH FEED KEY
<Z>
```

(Obtainable by the Acquisition of Key Information [SOH+KI] command.)

```
<A>
<l#>0
<IM>1
<Z>
```

(Obtainable by the Acquisition of Key Information [SOH+KI] command.)

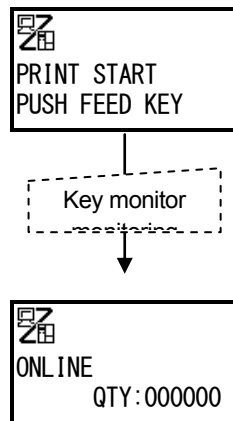

[Note]

1. This command is only enabled while online.
2. The key buffer size is 1KB. One key entry information requires 2 bytes and up to 512 information entries are available.
3. The key buffer acts as ring buffer. When the key entry exceeds the maximum entry capacity, the oldest entry information is overwritten.
4. When the exclusive use of key is initiated, the key buffer is initialized.
5. When the exclusive use of key is terminated, the key buffer is not initialized. As a result, key entry information is obtainable following this operation.
6. Label printing or label error detection is performed as usual even when the exclusive use of key is activated.
7. Error occurrence while the exclusive use of key is activated will release the exclusive state. After recovering from the error and going back online, the exclusive use of key becomes active again.
8. Exclusive use of key is initially off when powering on the printer.
9. The Key Entry <lZ> command is invalid when the exclusive use of key is activated.

1. Acquisition of key information command is as follows.

(1) Command

SOH + KI (01H 4BH 49H)

(2) Return status

[STX] + Number of key information + Key information string + [ETX]

1) The number of key information

Indicates the number of subsequent key information string (sequences).

The number of key information indicates the number of times the key is pressed.

Saved in ASCII decimal number, fixed 5-byte.

0	1	2	3	4
Ten-thousands place	Thousands place	Hundreds place	Tenths place	Unit digit

- Indicated by the numerical string from "00000" to "99999".
- When the number of key entry detection is under 5-digit, zero (0) is added to the start digit to indicate in 5-digit.

2) Key information string

The number of key information is indicated in a continuous format.

One key information is the binary value of 2-byte.

No.	Item	Description	No. of bytes
1	Key information	Key entry information Outputting the key ON/OFF state to bits corresponding to each key (See the following table). 0 : Key is not pressed. 1 : Key is pressed.	2

Bits corresponding to each key (2 bytes)

bit15	bit14	bit13	bit12	bit11	bit10	bit9	bit8	bit7	bit6	bit5	bit4	bit3	bit2	bit1	bit0
0	0	0	0	0	0	0	0	-	+	←	→	0	0	LINE	FEED

3) Acquisition sequence

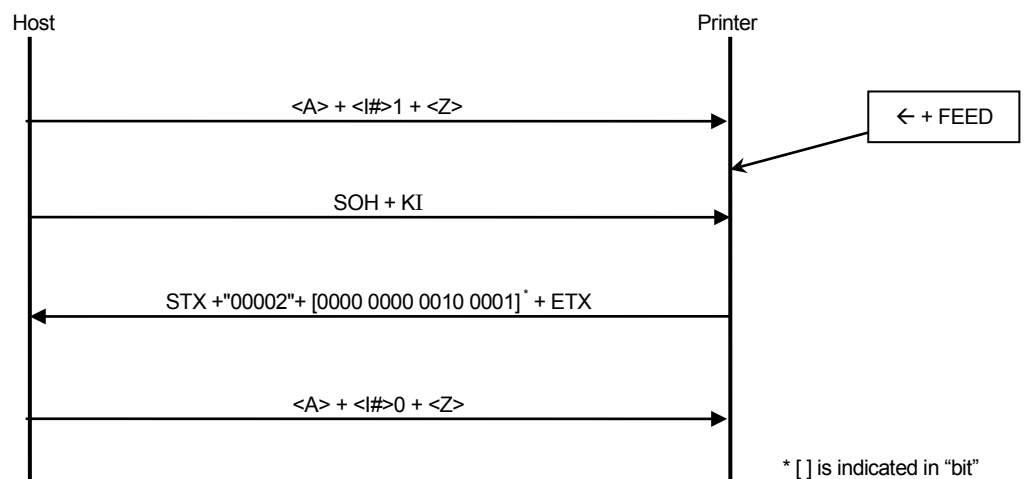

2. Key buffer initialization command can clear the stored key information in the key buffer.

(1) Command

SOH + KC (01H 4BH 43H)

(2) Return status

[STX] + 0 + [ETX] (02H 30H 03H)

0 is fixed.

15.8 Advanced Function

Key Entry			ESC+IZ
------------------	--	--	---------------

HEX code	ESC <1B> ₁₆	IZ <49> ₁₆ <5A> ₁₆	Parameter aa,bb,cc,ddd···d
Initial value	None		

Validity and valid duration of command	When the power switch is off	The set parameter is not maintained.
	Validity in a job	The set parameter becomes invalid.
	Validity after a job	The set parameter becomes invalid.

[Function]

Stores data entered through the operator panel in the internal buffer.

Use [+] and [-] keys to change data, [←] and [→] keys to move the cursor.

The FEED key determines the data input value to store in the buffer and change the screen image.

The input data will be retained up to 16 blocks of maximum 32-digit data on the internal buffer (RAM).

The Internal Buffer Call <IB> command can invoke the retained data to use as print data.

[Format]

<IZ>aa,bb,cc,ddd···d

• Parameter

a [Internal buffer number] = 1 to 16

b [Input digit number] = 1 to 32

c [Initial data] = Input digit number specified in "b" (Valid range: ASCII 20H ~ 7EH)

d [Data item name] = 16-digit of alphanumeric and symbol only

[Example]

<A>

<IZ>1,5,12345,DATA-

<IZ>2,4,0001,QTY

<Z>

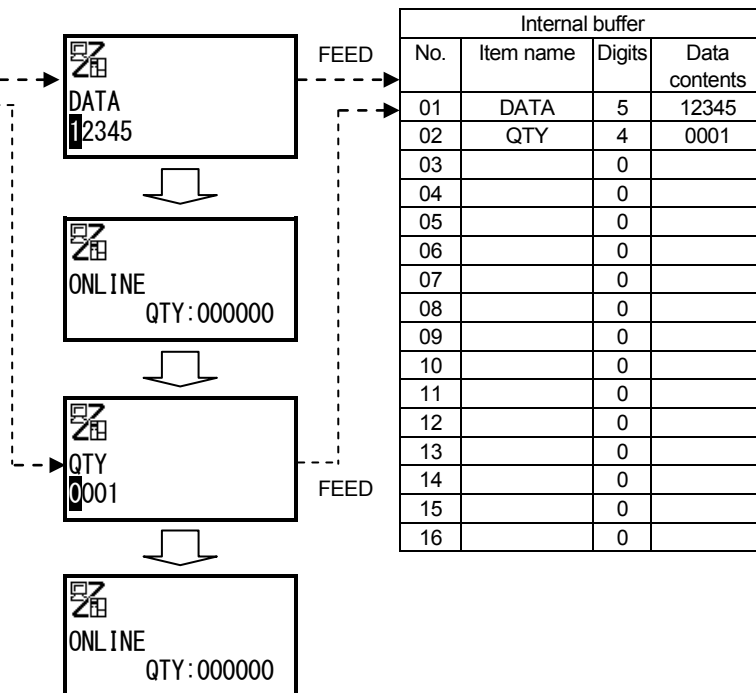

[Note]

1. Powering off the printer clears stored data.
2. Allows display input data up to 16-digit. When this limit is exceeded, [←] and [→] keys may be used to scroll to view the remaining.
3. The printer returns to the original screen following data input completion.
4. Data input and screen display is only available when online. In the offline or error state, the normal screen is displayed but data input is disabled.
5. The specified character string is left aligned for display. When less than 16 digits are used, space <20>₁₆ will be inserted.
6. The input digit number affects moving range of the cursor ([←] and [→] keys).
7. When the display data includes codes that cannot be displayed, it will be replaced by space <20>₁₆.
8. When changeable code range using [+] and [-] keys is from <20>₁₆ to <7E>₁₆ of ASCII.
9. When control codes such as <00>₁₆ to <1F>₁₆ of ASCII are included in the initial data, change cannot be made with key entry.
Even if changing codes with the input cursor, the relevant control code will be discarded when saving to the internal buffer.
10. A command error occurs when the input digit number and the initial data do not match.
11. The detection of a printer error while waiting for entry does not cause an error.
12. This <IZ> command is disabled when the exclusive use of key is activated by <I#>1.

15.9 Advanced Function

Internal Buffer Store (Receive Data)		ESC+IR	
HEX code	ESC <1B>16	IR <49>16<52>16	Parameter aa,bb(,cccc,d,eeee,ffff,gggg...g)
Initial value	None		

Validity and valid duration of command	When the power switch is off	The set parameter is not maintained.
	Validity in a job	The set parameter becomes invalid.
	Validity after a job	The set parameter becomes invalid.

[Function]

Stores data received from the sub port.

The obtained data will be retained up to 16 blocks of maximum 32-digit data on the internal buffer (RAM).

The Internal Buffer Call <IB> command can invoke the retained data to use as print data.

[Format]

<IR>aa,bb(,ccc,d,eee,ffff,gggg...g)

• Parameter

a	[Internal buffer number]	= 1 to 16
b	[Obtained digit number]	= 1 to 32
c	[Start position of receive data import]	= 0 to 9999 (Omissible)
d	[Terminate code digit number]	= 1 to 4 (Omissible)
e	[Terminate code]	= 4-digit without code range specification (Omissible)
f	[Timeout duration]	= 0 to 999999 (1 = 5ms) (Omissible)
g	[Data item name]	= 16-digit of alphanumeric and symbol (Omissible)

When omitting this parameter, the next command analysis does not start unless the specified number of data is received.

[Example 1] 6 bytes of receive data is stored in the internal buffer (Omitting start position, terminate code, timeout duration and data item name).

<A>
<IR>1,6
 <Z>

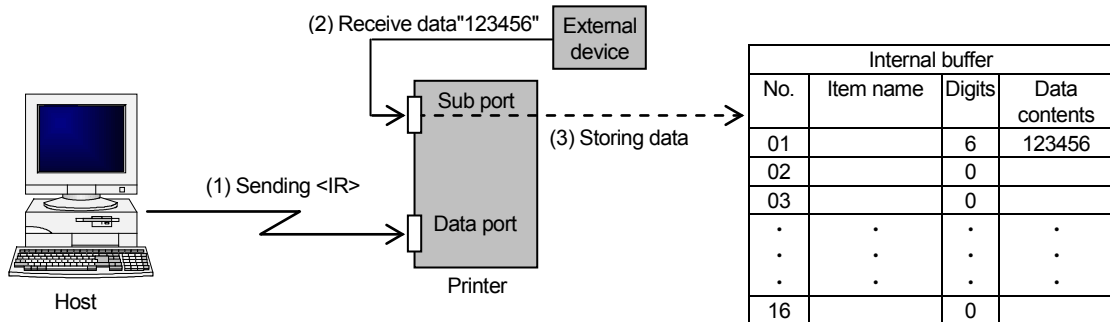

[Example 2] 6 bytes of receive data is stored in the internal buffer (Omitting start position and terminate code)

<A>
<IR>1,6,...,1000,ITEM_CODE
 <Z>

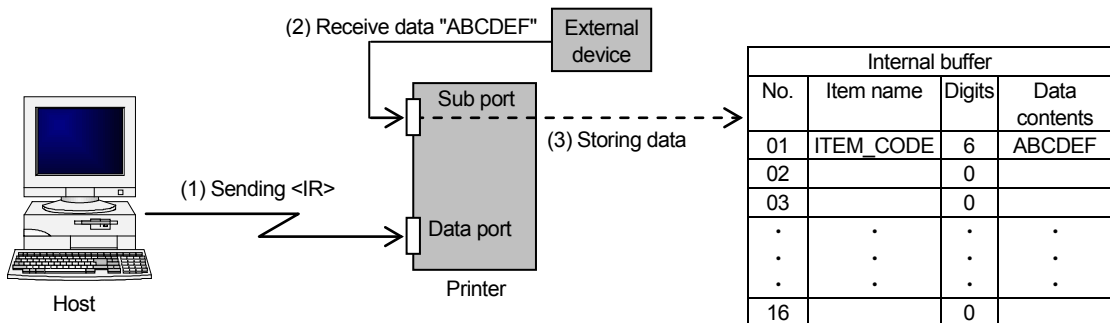

[Example 3] Specify start position of receive data import and terminate code and store them in the internal buffer
(Omits timeout duration and data item name).

```
<A>
<IR>1,32,1,2,*CR
<Z>
```

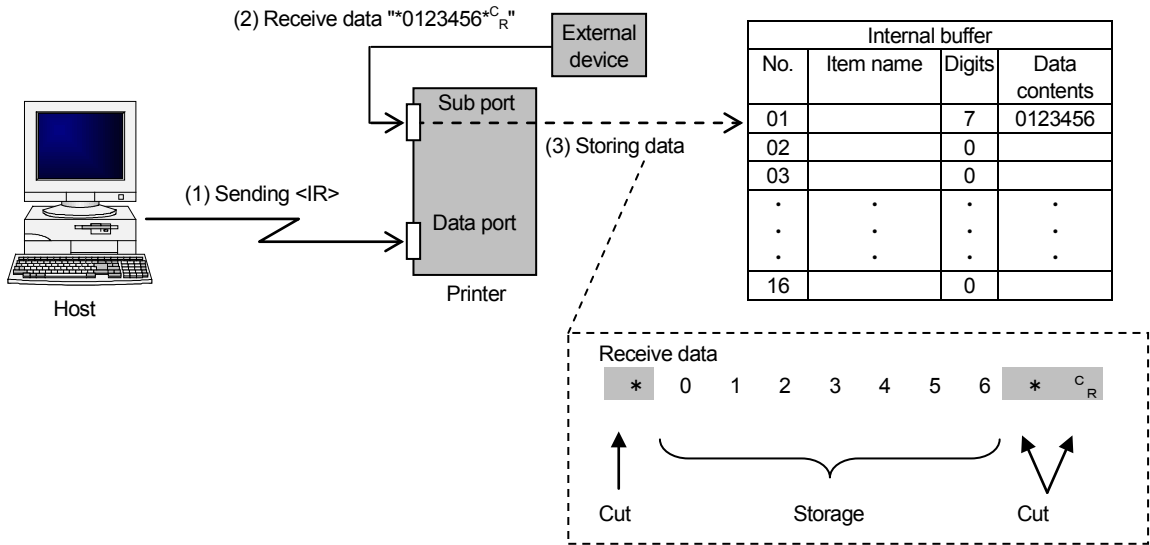

- * This method is suitable when the data to be discarded is placed before/after the receive data.
- * It is possible to omit either start position of receive data import or terminate code. Or both of them can be specified.
- * Digit number to be received is unknown, set 32 (Max. value) to the parameter of received digit number.

[Note]

1. Powering off the printer clears stored data.
2. This command cannot be used in combination with print data.
3. When receiving the data exceeding the specified digits, it will not be stored in the internal buffer.
4. Data port and sub port can be assigned depending on the interface mode setting of the LCD menu.
5. To obtain output data of the external device with this command, set sub port on the LCD to disable in advance.
6. To exit the standby state of data reception, try the following cancellation procedures.
 - (1) Send CAN to the data port
 - (2) Send Cancel Print Job through the LCD menu
7. When omitting terminate code after the digit number is specified, 00₁₆ will be recognized as terminate code and processed based on the specified digit number.
8. Timeout duration is the waiting time per 1 byte of receive data. Receiving every single byte will clear the monitoring time, and then the specified waiting time will be active based on the specified obtained digit number.
9. In case of timeout, the digit number of the internal buffer will be the byte quantity actually received and the command operation will be terminated.
10. In case of timeout, the command operation will be terminated normally with or without receiving the specified number of data.
11. In case of command termination due to timeout, part of the received terminate code may be stored in the buffer. In this case, set the extra time to the timeout duration.
12. When the received data is lower than the obtained digit number, it goes to the standby state for the specified timeout duration.
13. When the number of received data is beyond the obtained digit number, it is stored in the internal buffer and the rest will be left in the receive buffer of sub port.

15.10 Advanced Function

Data Transmission		ESC+IT	
HEX code	ESC <1B> ₁₆	IT <49> ₁₆ <54> ₁₆	Parameter a,b(.cccc,ddd···d)
Initial value	None		
Validity and valid duration of command	When the power switch is off	The set parameter is not maintained.	
	Validity in a job	The set parameter becomes invalid.	
	Validity after a job	The set parameter becomes invalid.	

[Function]

Sends data to the specified port.
Up to 1024-byte data can be sent.

[Format]

<IT>a,b(.cccc,ddd···d)

• Parameter

- a [Data transport port] = 1 : Data port
2 : Sub port
- b [Transmission text format] = 0 : No additional code
1 : Adds STX(02H) at the start and ETX(03H) at the end
2 : Adds CRLF(0D0AH) at the end
3 : Adds CR(0DH) at the end
- c [Transmission digit number] = 1 to 1024 (Omissible)
- d [Transmission data] = No code limitation for the digit number specified in "c" (Omissible)

[Example 1] Send the data from the host computer to the external device via the printer.

<A>
<IT>2,0,6,123456
<Z>

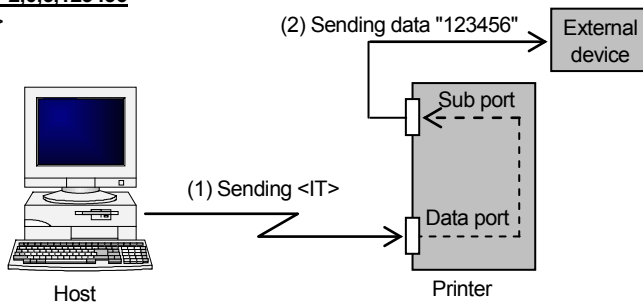

[Example 2] Uploads the internal buffer contents from the host computer.

<A>
<IB>1
<IT>1,2
<Z>

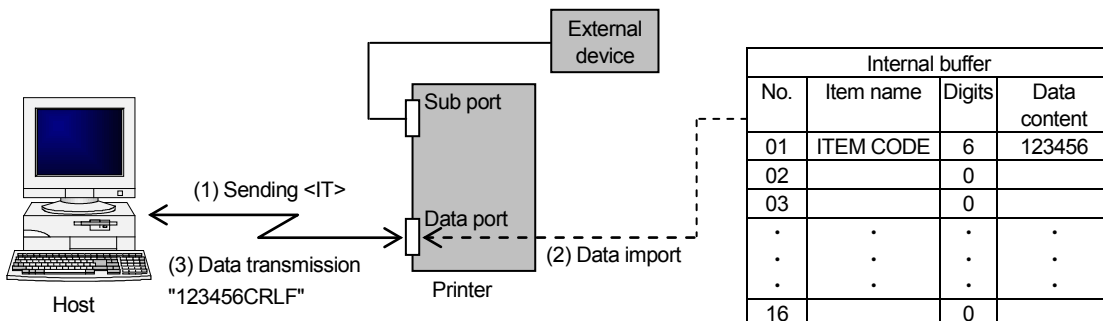

[Note]

- This command cannot be used in combination with print data.
- The data transmission is available only with bidirectional interface communication.
- Data port/Sub port can be assigned depending on the interface mode setting of the LCD menu.
- When the transmission digit number and the value of transmission data do not match, subsequent data may not be properly analyzed.
- When the cable for sub port is not connected, no data is sent to the external device.

6. To transfer the data to the external device, select sub port in [INTERFACE PORT] of interface mode, and then enable "EXTERNAL DEVICE". If not, this <IT> command causes a command error.
7. In [Example 2], it is necessary to invoke the internal buffer with the <IB> command.
8. Setting "PROTOCOL" for the data port returns ACK after processing a single item. In [Example 2], ACK(0x06) is sent immediately after uploading data based on the protocol rule.
9. As a similar command, the Request to Obtain Receive Data command is available.
With the reception of this command, the data received from the status port returns to the data port.

(1) Command
SOH(01H) + RD

(2) Return status
[STX] + Receive byte number, + Receive data + [ETX]

(3) List of return status

No.	Item	Description	No. of bytes
1	Received byte number	Received data number (0 to 10240)	5
2	Receive data	Data received from status port	Received byte number

(4) Sequence

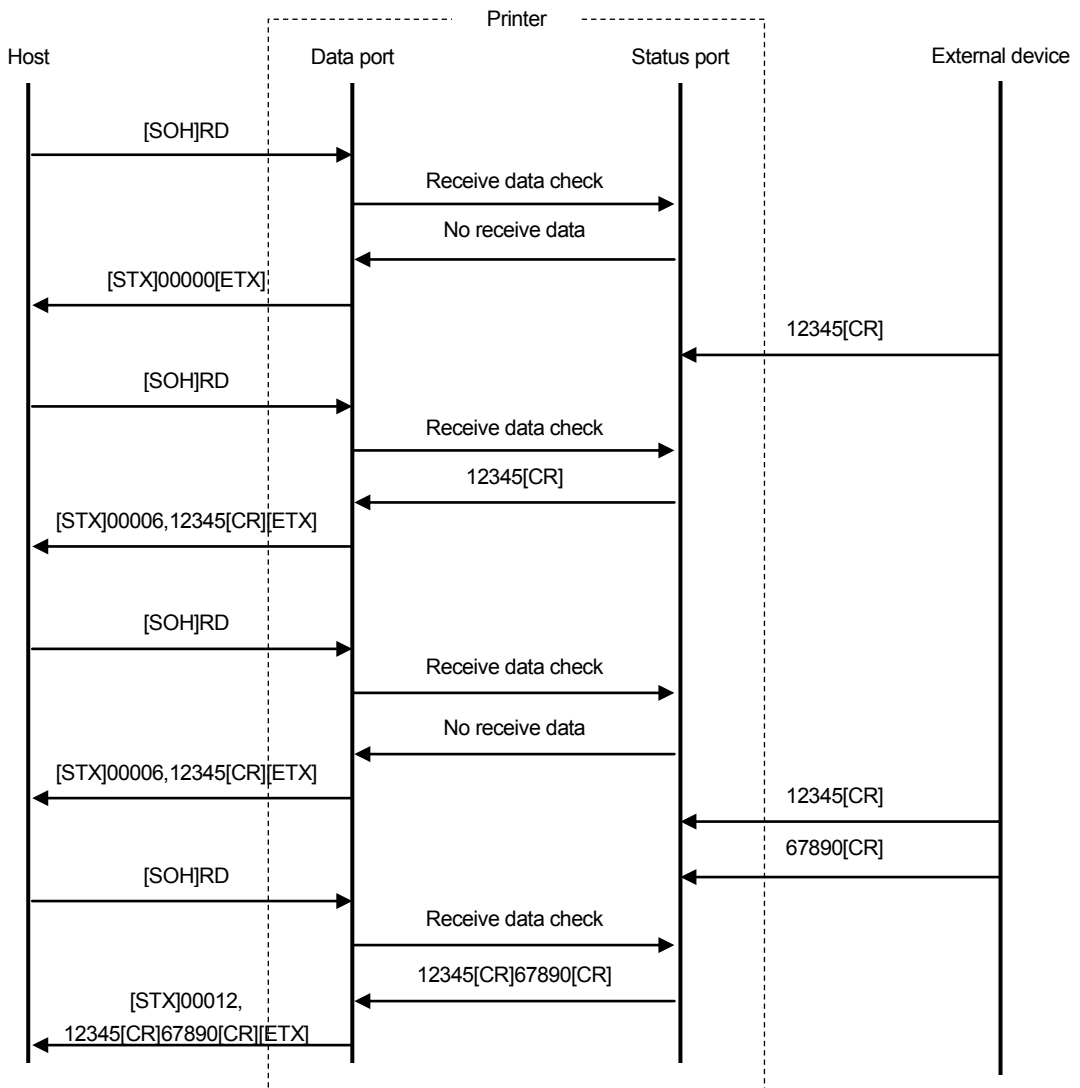

15.11 Advanced Function

External Signal Input / Output		ESC+IO	
---------------------------------------	--	---------------	--

HEX code	ESC <1B> ₁₆	IO <49> ₁₆ <4F> ₁₆	Parameter a,b,c,(dddd)
Initial value	None		

Validity and valid duration of command	When the power switch is off	The set parameter is not maintained.
	Validity in a job	The set parameter becomes invalid.
	Validity after a job	The set parameter becomes invalid.

[Function]

Specifies the input and output of pin number for external signals.

[Format]

<IO>a,b,c,(dddd)

• Parameter

- a [Input / Output direction] = 0 : Input
1 : Output
- b [Pin number] = 1 to 14
- c [Input / Output level] = 0 : LOW level
1 : HIGH level
- d [Timeout duration for input] = 0 to 999999 (1 = 5ms) (Omissible)
When [Input / Output direction] is set to [0: Input], this parameter sets the timeout duration for input.
If omitting this parameter, the next command analysis does not start unless there is an input from the specified port.
- [Output time] = 0 to 999999 (1 = 5ms) (Omissible)
When [Input / Output direction] is set to [1: Output], this parameter sets output time.
If specifying this parameter, the signal level goes back to the state before this command is specified after the specified time elapsed.
Omitting this parameter keeps outputting the signal at a specified output level.

[Example 1] Waiting for the input of HIGH level from EXT5 pin (Timeout duration is 5 seconds)

```
<A>
<IO>0,5,1,1000
<Z>
```

[Example 2] Outputting LOW level signal to EXT1 pin for 5 seconds (HIGH signal level before specifying this command)

```
<A>
<IO>1,1,0,1000
<Z>
```

[Note]

1. To use this command, set [EXTERNAL SIGNAL] to "DISABLE" in the Advanced Mode. Selecting "ENABLE" changes the signal regardless of this command specification because the signal output is performed on the printer side.
2. Signal output timing is nothing to do with the print operation. When the command is processed, the signal is output.
3. Refer to the table on the next page for input and output direction.
4. There may be approximately 5 ms difference between the specified output time and the actual signal output timing.
5. When the output level and the current output level are the same, the output level does not change even after the specified output time duration has elapsed.

[Input and output direction]

Pin No.	Input/Output	Pin No.	Input/Output
1	Output	11	Input
2	-	12	-
3	Output	13	-
4	Output	14	-
5	Input		
6	Output		
7	Input		
8	-		
9	* Input/Output		
10	Output		

* Pin No. 9 is switchable by jumper SW (SW3) on the external signal board.

15.12 Advanced Function

Print Time Delay		ESC+IW	
HEX code	ESC	IW	Parameter
	<1B> ₁₆	<49> ₁₆ <57> ₁₆	aaaaaa
Initial value	None		

Validity and valid duration of command	When the power switch is off	The set parameter is not maintained.
	Validity in a job	The set parameter becomes invalid.
	Validity after a job	The set parameter becomes invalid.

[Function]

Specifies the waiting time before starting to print.

[Format]

<IW>aaaaaa

• Parameter

a [Waiting time before starting to print] = 0 to 999999 (1 = 5ms)

[Example] Waits for 5 seconds

```
<A>
<IW>1000
Print data
<Q>1
<Z>
```

In the above example, there is a 5-second interval from the completion of print data editing to the start of print operation.

[Note]

1. When multiple print data items are continuously received, printing begins after the time lapse specified following the completion of the previous print item.
2. When a quantity of label is specified with the Print Quantity <Q> command, the delay is only valid for the first label and all others will be printed continuously without delay.
3. This command is invalid when the external signal is enabled.
4. Specify this command in combination with the print data. This command is invalid in the absence of print data.
5. If a print error occurs while waiting for print start or in offline state, the delay time specified when resuming to print becomes valid.
6. If printing is suspended with DLE (request command to pause printing) while waiting for print start, the waiting time will also be canceled. By resuming operation with DC1 (request command to resume printing), printing begins at the suspended point.
7. When reprinting with the Repeat <C> command and the function key, the delay time is ignored.

15.13 Advanced Function

Audible Buzzer		ESC+IU	
HEX code	ESC <1B> ₁₆	IU <49> ₁₆ <55> ₁₆	Parameter a
Initial value	None		

Validity and valid duration of command	When the power switch is off	The set parameter is not maintained.
	Validity in a job	The set parameter becomes invalid.
	Validity after a job	The set parameter becomes invalid.

[Function]

Activates the integrated printer buzzer.

[Format]

<IU>a

- Parameter

a [Tone specification] = 0 to 4

- 0 : One short sound
- 1 : One prolonged sound
- 2 : Two consecutively short sounds
- 3 : Two consecutively prolonged sound
- 4 : Three consecutively prolonged sound

[Example]

One short sound

```
<A>
<IU>0
<Z>
```

[Note]

1. The duration range is from 175ms to 400ms.
2. Increments of 5ms or more between each of the consecutive sounds (Tone 2, 3 and 4).
3. Analysis of the receive data is suspended during the sounding of the buzzer.
4. In multi buffer operation, timing of the buzzer may not be in exact timing with the item currently printing. To synchronize the two, obtain the printer status and create this command.

15.14 Advanced Function

Initialization of Internal Buffer

ESC+I@

HEX code	ESC	I@	Parameter
	<1B> ₁₆	<49> ₁₆ <40> ₁₆	(aa)
Initial value	None		

Validity and valid duration of command	When the power switch is off	The set parameter is not maintained.
	Validity in a job	The set parameter becomes invalid.
	Validity after a job	The set parameter becomes invalid.

[Function]

Initializes internal buffer.

[Format]

<I@>(aa)

• Parameter

a [Internal buffer No. to be initialized] = 1 to 16 (Omissible)

When buffer number is omitted, all buffers will be initialized.

[Example 1] Initialization of internal buffer number 6

<A>
<I@>06
<Z>

[Example 2] Initialization of all internal buffers

<A>
<I@>
<Z>

Internal buffer			
No.	Item name	Digits	Data contents
01	DATA1	2	49
02	DATA2	6	123456
03	DATA3	4	1234
04		0	
05		0	
06	QTY	4	0010
07		0	
08		0	
09		0	
10		0	
11		0	
12		0	
13		0	
14		0	
15		0	
16		0	

[Note]

1. Do not specify this command with the Data Reception <IR> command and Data Transmission <IT> command in the same job.
2. Once the internal buffer is initialized, it cannot be undone.
3. After initialization, the digits of corresponding buffer number becomes zero, and the character strings for item name and data contents are deleted.

Appendix Unicode Code Table (Special Kanji)

Refer to the table below for special Kanji JIS/Unicode.

(1) Ryobi font

Code	JIS	0	1	2	3	4	5	6	7	8	9	A	B	C	D	E	F	
13 区	2D2		①	②	③	④	⑤	⑥	⑦	⑧	⑨	⑩	⑪	⑫	⑬	⑭	⑮	
			2460	2461	2462	2463	2464	2465	2466	2467	2468	2469	246A	246B	246C	246D	246E	
	2D3	⑯	⑰	⑱	⑲	⑳	I	II	III	IV	V	VI	VII	VIII	IX	X		
		246F	2470	2471	2472	2473	2160	2161	2162	2163	2164	2165	2166	2167	2168	2169		
	2D4	ミリ	キロ	センチ	メートル	グラム	トン	アール	ヘクタール	リットル	フット	キロ	ドル	セント	パーセント	リットル	グー	
		3349	3314	3322	334D	3318	3327	3303	3336	3351	3357	330D	3326	3323	332B	334A	333B	
	2D5	mm	cm	km	mg	kg	cc	m ²										平成
		339C	339D	339E	338E	338F	33C4	33A1										337B
	2D6	”	”	No	KK	Tel	Ⓐ	Ⓑ	Ⓒ	Ⓓ	Ⓔ	(株)	(有)	(代)	明	大	和	
		301D	301F	2116	33CD	2121	32A4	32A5	32A6	32A7	32A8	3231	3232	3239	337E	337D	337C	
2D7	≡	≡	∫	φ	Σ	√	⊥	∠	L	△	∴	∩	∪					
	2252	2261	222B	222E	2211	221A	22A5	2220	221F	22BF	2235	2229	222A					

(2) NEC font

Code	JIS	0	1	2	3	4	5	6	7	8	9	A	B	C	D	E	F
13 区	2D2		①	②	③	④	⑤	⑥	⑦	⑧	⑨	⑩	⑪	⑫	⑬	⑭	⑮
			2460	2461	2462	2463	2464	2465	2466	2467	2468	2469	246A	246B	246C	246D	246E
	2D3	⑯	⑰	⑱	⑲	⑳	I	II	III	IV	V	VI	VII	VIII	IX	X	XI
		246F	2470	2471	2472	2473	2160	2161	2162	2163	2164	2165	2166	2167	2168	2169	216A
	2D4	ミリ	キロ	センチ	メートル	グラム	トン	アール	ヘクタール	リットル	フット	キロ	ドル	セント	パーセント	リットル	グー
		3349	3314	3322	334D	3318	3327	3303	3336	3351	3357	330D	3326	3323	332B	334A	333B
	2D5	mm	cm	km	mg	kg	cc	m ²	cm ²	Hz		キロメートル	キロワット	リットル	XII		
		339C	339D	339E	338E	338F	33C4	33A1	33A0	3390		3316	3315	3339	216B		
	2D6	㊦	㊧	No	KK	Tel							(株)	(有)	(代)		
		3004	E065	2116	33CD	2121						3231	3232	3239			
2D7	(社)	(資)	(財)	Xi	Xii	i	ii	iii	iv	v	vi	vii	viii	ix	x		
	3233	323E	3226	217A	217B	2170	2171	2172	2173	2174	2175	2176	2177	2178	2179		

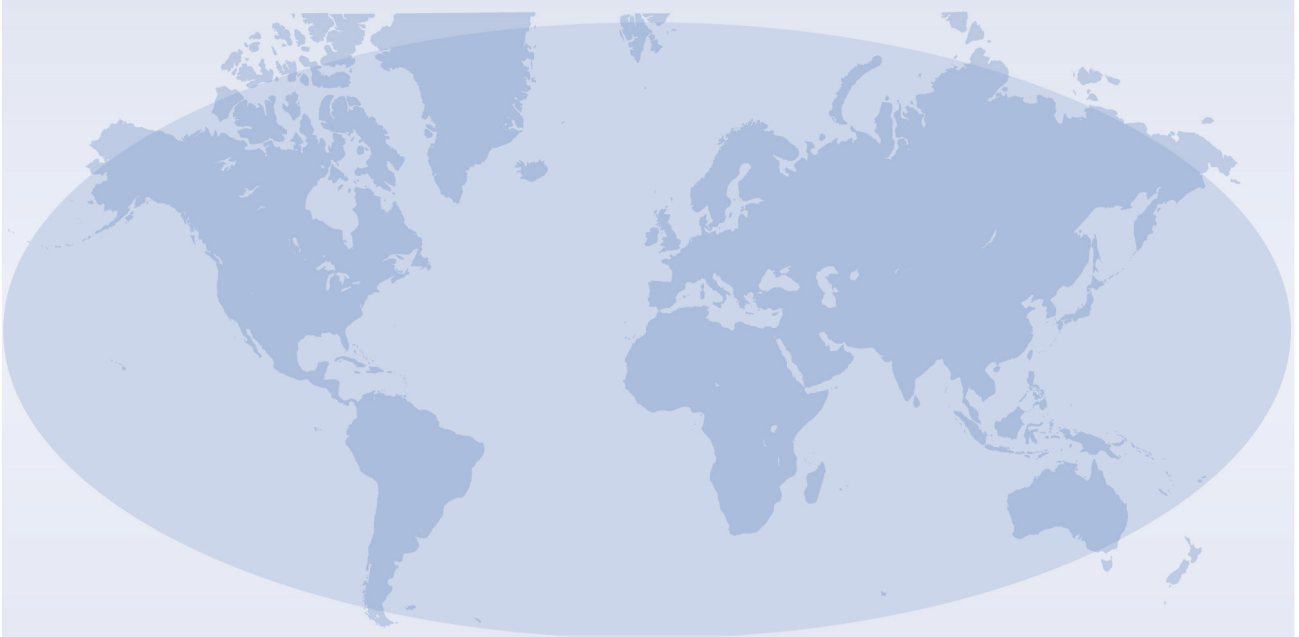

Extensive contact information of worldwide SATO operations can be found on the Internet at <http://www.satoworldwide.com>