

Quest rent

*Ser 1146
9/18/90
N-1814*

NCEL

Technical Note

May 1990

By T. Y. Richard Lee, Ph.D.

Sponsored By Office of
Naval Research

USER DATA PACKAGE (UDP) FOR PACKAGED COGENERATION SYSTEMS (PCS)

ABSTRACT The User Data Package (UDP) for the Packaged Cogeneration System (PCS) has been developed to facilitate the transition of small decentralized cogeneration technology into the Naval shore establishment.

The purpose of this UDP is to assist in the planning, design, procurement, operation, and maintenance phases for packaged cogeneration systems at Naval facilities. Several sources of information were used in the development of the UDP, including Navy documents, cogeneration industry reports, cogeneration literature, data from cogeneration installations, and electric and gas utility reports.

The information provided in this UDP will enable Navy engineers to consider cogeneration options for facility installations, assist in the evaluation of PCS options, and aid in the selection of the most cost-effective and practical system. The information in the UDP will also assist in the procurement and operation of the PCS. Data to improve the management of contracts for the installation, operation, or maintenance of the cogeneration unit are also provided.

NAVAL CIVIL ENGINEERING LABORATORY PORT HUENEME CALIFORNIA 93043-5003

METRIC CONVERSION FACTORS

| Approximate Conversions to Metric Measures | | | | Approximate Conversions from Metric Measures | | | |
|--|------------------------|----------------------------|---------------------|--|-----------------------------------|-------------------|------------------------|
| Symbol | When You Know | Multiply by | To Find | Symbol | When You Know | Multiply by | To Find |
| LENGTH | | | | | | | |
| in | inches | *2.5 | centimeters | mm | millimeters | 0.04 | inches |
| ft | feet | 30 | centimeters | cm | centimeters | 0.4 | inches |
| yd | yards | 0.9 | meters | m | meters | 3.3 | feet |
| mi | miles | 1.6 | kilometers | m | meters | 1.1 | yards |
| | | | | km | kilometers | 0.6 | miles |
| AREA | | | | | | | |
| in ² | square inches | 6.5 | square centimeters | cm ² | square centimeters | 0.16 | square inches |
| ft ² | square feet | 0.09 | square meters | m ² | square meters | 1.2 | square yards |
| yd ² | square yards | 0.8 | square meters | km ² | square kilometers | 0.4 | square miles |
| mi ² | square miles | 2.6 | square kilometers | ha | hectares (10,000 m ²) | 2.5 | acres |
| | acres | 0.4 | hectares | | | | |
| MASS (weight) | | | | | | | |
| oz | ounces | 28 | grams | g | grams | 0.035 | ounces |
| lb | pounds | 0.45 | kilograms | kg | kilograms | 2.2 | pounds |
| | short tons | 0.9 | tonnes | t | tonnes (1,000 kg) | 1.1 | short tons |
| | (2,000 lb) | | | | | | |
| VOLUME | | | | | | | |
| tsp | teaspoons | 5 | milliliters | ml | milliliters | 0.03 | fluid ounces |
| Tbsp | tablespoons | 15 | milliliters | l | liters | 2.1 | pints |
| fl oz | fluid ounces | 30 | milliliters | l | liters | 1.06 | quarts |
| c | cups | 0.24 | liters | l | liters | 0.26 | gallons |
| pt | pints | 0.47 | liters | m ³ | cubic meters | 35 | cubic feet |
| qt | quarts | 0.95 | liters | m ³ | cubic meters | 1.3 | cubic yards |
| gal | gallons | 3.8 | liters | | | | |
| ft ³ | cubic feet | 0.03 | cubic meters | °C | Celsius temperature | 9/5 (then add 32) | Fahrenheit temperature |
| yd ³ | cubic yards | 0.76 | cubic meters | | | | |
| TEMPERATURE (exact) | | | | | | | |
| °F | Fahrenheit temperature | 5/9 (after subtracting 32) | Celsius temperature | °C | Celsius temperature | | Fahrenheit temperature |

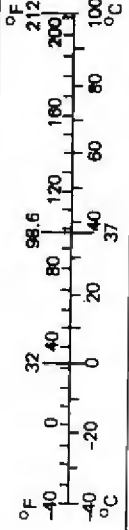
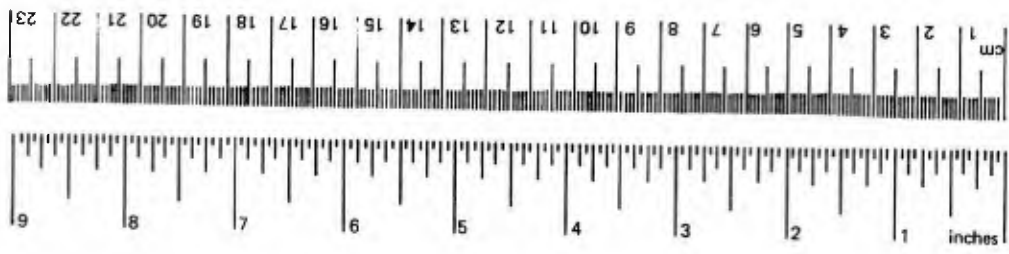

*1 in = 2.54 (exactly). For other exact conversions and more detailed tables, see NBS Misc. Publ. 286, Units of Weights and Measures, Price \$2.25, SD Catalog No. C13.10:286.

| REPORT DOCUMENTATION PAGE | | | Form Approved OMB No. 0704-018 | |
|---|--|---|---|--|
| Public reporting burden for this collection of information is estimated to average 1 hour per response, including the time for reviewing instructions, searching existing data sources, gathering and maintaining the data needed, and completing and reviewing the collection of information. Send comments regarding this burden estimate or any other aspect of this collection information, including suggestions for reducing this burden, to Washington Headquarters Services, Directorate for Information and Reports, 1215 Jefferson Davis Highway, Suite 1204, Arlington, VA 22202-4302, and to the Office of Management and Budget, Paperwork Reduction Project (0704-0188), Washington, DC 20503. | | | | |
| 1. AGENCY USE ONLY (Leave blank) | 2. REPORT DATE May 1990 | | 3. REPORT TYPE AND DATES COVERED Final - Dec 1988 - May 1990 | |
| 4. TITLE AND SUBTITLE User Data Package (UDP) for Packaged Cogeneration Systems (PCS) | | | 5. FUNDING NUMBERS PR - 371-804-141B WU - DN987115 | |
| 6. AUTHOR(S) T. Y. Richard Lee, Ph.D. | | | | |
| 7. PERFORMING ORGANIZATION NAME(S) AND ADDRESS(S) Naval Civil Engineering Laboratory Port Hueneme, CA 93043-5003 | | | 8. PERFORMING ORGANIZATION REPORT NUMBER TN - 1814 | |
| 9. SPONSORING/MONITORING AGENCY NAME(S) AND ADDRESS(S) Office of Naval Research 800 S. Quincy Street Alexandria, VA 22332 | | | 10. SPONSORING/MONITORING AGENCY REPORT NUMBER | |
| 11. SUPPLEMENTARY NOTES | | | | |
| 12a. DISTRIBUTION/AVAILABILITY STATEMENT Approved for public release; distribution is unlimited. | | | 12b. DISTRIBUTION CODE | |
| 13. ABSTRACT (Maximum 200 words) <p>The User Data Package (UDP) for the Packaged Cogeneration System (PCS) has been developed to facilitate the transition of small decentralized cogeneration technology into the Naval shore establishment.</p> <p>The purpose of this UDP is to assist in the planning, design, procurement, operation, and maintenance phases for packaged cogeneration systems at Naval facilities. Several sources of information were used in the development of the UDP, including Navy documents, cogeneration industry reports, cogeneration literature, data from cogeneration installations, and electric and gas utility reports.</p> <p>The information provided in this UDP will enable Navy engineers to consider cogeneration options for facility installations, assist in the evaluation of PCS options, and aid in the selection of the most cost-effective and practical system. The information in the UDP will also assist in the procurement and operation of the PCS. Data to improve the management of contracts for the installation, operation, or maintenance of the cogeneration unit are also provided.</p> | | | | |
| 14. SUBJECT TERMS Energy, cogeneration, generator, RAM, electricity, domestic hot water | | | 15. NUMBER OF PAGES 171 | |
| | | | 16. PRICE CODE | |
| 17. SECURITY CLASSIFICATION OF REPORT Unclassified | 18. SECURITY CLASSIFICATION OF THIS PAGE Unclassified | 19. SECURITY CLASSIFICATION OF ABSTRACT Unclassified | 20. LIMITATION OF ABSTRACT UL | |

Table of Contents

| | Page |
|---|------|
| I. General Overview | 1 |
| 1.1 Introduction | 1 |
| 1.2 Process Description | 3 |
| 1.3 Small Cogeneration System Efficiency | 8 |
| 1.4 Thermal Energy Storage (TES) | 9 |
| 1.5 PCS Applications and Market Potential | 11 |
| 1.5.1 Commercial Applications and Market Potential | 11 |
| 1.5.2 Navy PCS Applications and Market Potential | 14 |
| 1.5.3 Treasure Island Packaged Cogeneration System | 17 |
| 1.5.4 Camp Pendleton Packaged Cogeneration Systems | 17 |
| II. Planning | 19 |
| 2.1 Overview | 19 |
| 2.2 Recommended Modifications to NAVEAC P-Publications | 19 |
| 2.2.1 Input to NAVEAC P-72 | 19 |
| 2.2.2 Input to NAVEAC P-80 | 21 |
| 2.3 PCS Feasibility | 22 |
| 2.3.1 Technical Feasibility Assessment | 22 |
| 2.3.2 Economic Feasibility Assessment | 28 |
| 2.3.3 Computer Software | 30 |
| 2.3.4 Regulatory Considerations | 39 |
| 2.4 Financing Options | 43 |

Table of Contents (Cont)

| | Page |
|---|------|
| III. Design | 45 |
| 3.1 Recommended Modifications to NAVFAC Design Criteria | 45 |
| 3.2 Design Considerations | 46 |
| IV. Specifications | 49 |
| 4.1 Camp Pendleton Procurement Specifications | 49 |
| V. Construction/Procurement | 51 |
| 5.1 List of Potential PCS Vendors | 51 |
| 5.2 Cost Considerations | 55 |
| VI. Maintenance and Operation | 59 |
| 6.1 Overview | 59 |
| 6.2 Integrated Logistics Support for the PCS | 59 |
| 6.2.1 Maintenance | 59 |
| 6.2.2 Manpower | 60 |
| 6.2.3 Supply Support | 61 |
| 6.2.4 Test and Evaluation Equipment | 62 |
| 6.2.5 Training | 62 |
| 6.2.6 Technical Data | 63 |
| 6.2.7 Packaging, Handling, Storage, and Transportation | 63 |
| 6.3 Reliability, Availability, and Maintainability (RAM) for PCS | 64 |
| 6.3.1 Methodology Used in the Analysis | 65 |
| 6.3.2 RAM Data Base | 70 |
| 6.3.3 Summary of Major Findings | 86 |

Table of Contents (Cont)

| | Page |
|---|------|
| Acknowledgments | 89 |
| References | 89 |
| Appendixes | |
| A List of Candidate PCS Applications | A-1 |
| B Annual Performance Report for Naval Station, Treasure Island | B-1 |
| C Data Collection Forms | C-1 |
| D Camp Pendleton Procurement Specification | D-1 |

List of Tables

| | Page |
|--|------|
| 1.1 Small Cogeneration System Options | 4 |
| 1.2 Operating Efficiency Standards for PURPA Compliance | 10 |
| 1.3 Selected Commercial, Institutional, and Multi-unit Technically Feasible Sites | 11 |
| 1.4 Distribution of PCS Installations by Geographical Area | 12 |
| 1.5 Distribution of PCS Installations by Building Type . . | 13 |
| 1.6 Distribution of PCS Installations by Capacity | 13 |
| 1.7 Distribution of PCS Installations by Manufacturer/Packager | 14 |
| 1.8 Number of PCS Candidates by Facility Type | 15 |
| 1.9 Additional Facility Types Appropriate for PCS | 16 |
| 2.1 Data Requirements for Feasibility Analysis | 23 |
| 2.2 Cogeneration Analysis Software | 30 |
| 2.3 Emission Levels Considered Significant Under PSD Regulations | 40 |
| 2.4 Potential Environmental Approvals For Packaged Cogeneration Systems | 42 |
| 5.1 Packaged Cogeneration System (PCS) Suppliers and Related Information | 51 |
| 5.2 Integration (Soft) Cost Labor | 57 |
| 6.1 Estimated Hours Needed for PCS Service | 61 |
| 6.2 U.S. Naval Station Treasure Island Drawings | 63 |
| 6.3 Distribution of Systems by Facility Type | 70 |
| 6.4 Distribution of Systems by Manufacturer | 71 |
| 6.5 Distribution of Systems by Size and Number of Units | 71 |

List of Tables (Cont)

| | Page |
|---|------|
| 6.6 Availability and Service Factor by Emission Controls and by Absorption Chillers | 73 |
| 6.7 Average Availability and Service Factor of PCS by Presence of Maintenance Contract | 74 |
| 6.8 Average Availability and Service Factor by Power Interchange with the Utility | 75 |
| 6.9a Average Availability of Small Cogeneration Systems by System Operating Mode | 76 |
| 6.9b Average Service Factor of Small Cogeneration Systems by Operating Mode | 77 |
| 6.10a Average Availability of Small Cogeneration Units by Year of Operation by Calendar Year | 78 |
| 6.10b Average Service Factor of Small Cogeneration Systems by Year of Operation by Calendar Year | 79 |
| 6.11a Scheduled Outage Factor Data | 80 |
| 6.11b Forced Outage Factor Data | 81 |
| 6.12 Failure Analysis-Number of Sites Reporting Failures.. | 82 |
| 6.13 Impact of Size of Unit on RAM | 84 |
| 6.14 Subsystems Requiring Frequent Repair | 85 |

List of Figures

| | Page |
|---|------|
| 1.1 Packaged Cogeneration System Acquisition/Implementation Process | 2 |
| 1.2 Efficiencies for Cogeneration and Power Generation Plants | 3 |
| 1.3a Reciprocating-Engine Cogeneration System | 5 |
| 1.3b Gas Turbine With Heat Recovery Cogeneration System | 5 |
| 1.4 Schematic of a Typical PCS Application | 6 |
| 5.1 Correlation of Total Installed Costs (\$/kW) with Site Installed kW | 56 |
| 6.1 IEEE Standard 762 RAM Definition | 68 |
| 6.2 Standard DOD 3235.1 RAM Definition | 69 |

I. General Overview

1.1 Introduction

The User Data Package (UDP) for the Packaged Cogeneration System (PCS) has been developed to facilitate the transition of small decentralized cogeneration technology into the Naval shore establishment. The specific data and information needed to support the implementation of PCS are documented in the following sections of this report:

- * Planning (Section II)
 - Recommended Modifications to NAVFAC P-Publications Feasibility
 - Technical
 - Economic
 - Regulations
- * Design (Section III)
 - Recommended Modifications to NAVFAC Design Criteria
- * Specifications (Section IV)
 - Camp Pendleton Procurement Specifications
- * Construction/Procurement (Section V)
 - List of Potential PCS Vendors
- * Maintenance and Operation (Section VI)
 - Integrated Logistics Support for the PCS
 - Reliability, Availability, and Maintainability (RAM) for PCS

Figure 1.1 shows a network diagram of the acquisition and implementation process for PCS applications. Responsibilities for the primary implementation functions are also defined.

The purpose of this UDP is to assist in the planning, design, procurement, operation, and maintenance phases for packaged cogeneration systems at Naval facilities. Several sources of information were used in the development of the UDP, including Navy documents, cogeneration industry reports, cogeneration literature, data from cogeneration installations, and electric and gas utility reports.

The information provided in this UDP will enable Navy engineers to consider cogeneration options for facility installations, assist in the evaluation of PCS options, and aid in the selection of the most cost-effective and practical system. The information in the UDP will also assist in the procurement and operation of the PCS. Data to improve the management of contracts for the installation, operation, or maintenance of the cogeneration unit are also provided.

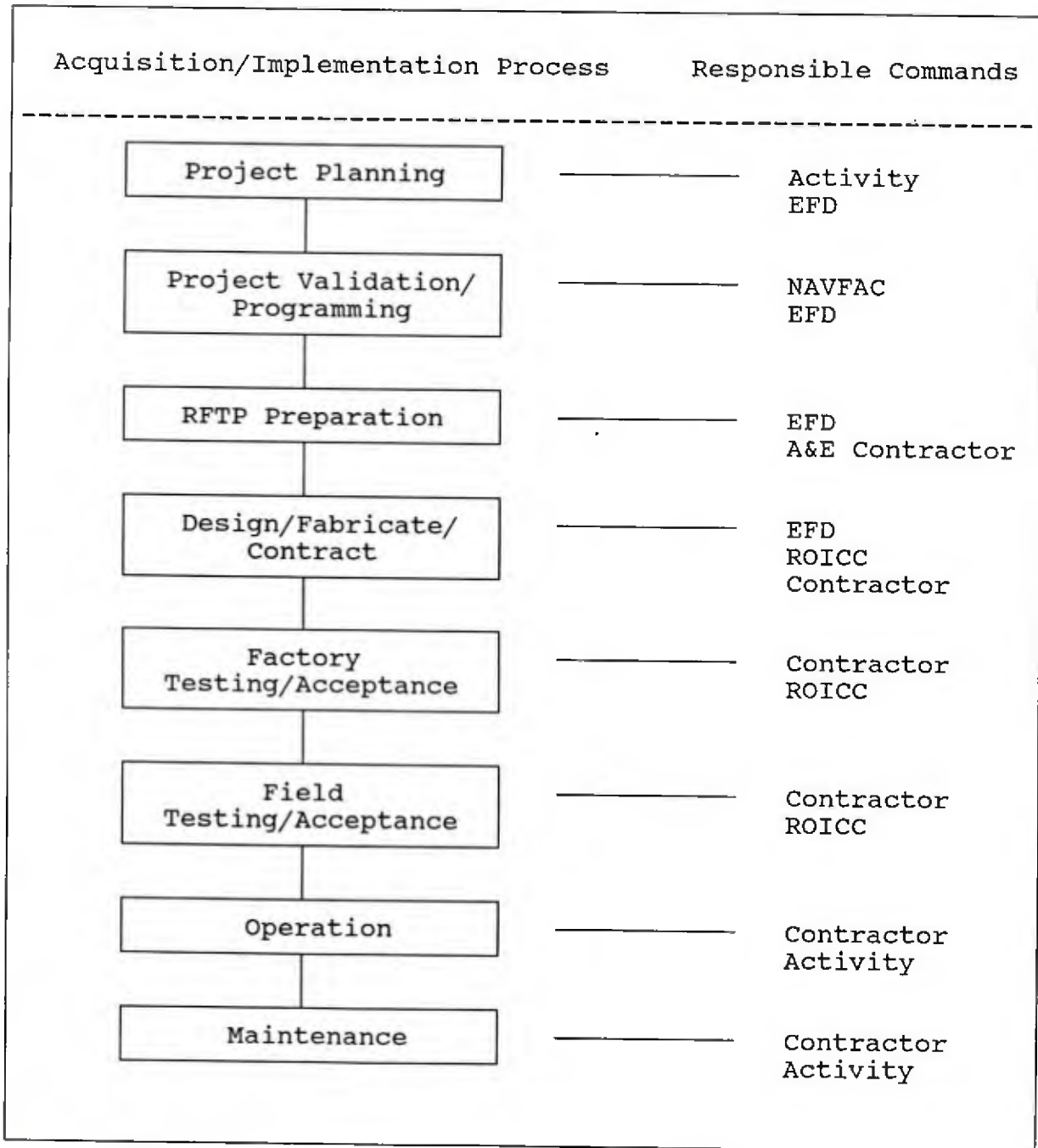

Figure 1.1 Packaged Cogeneration System
Acquisition/Implementation Process

1.2 Process Description

Cogeneration is the simultaneous generation of electricity and thermal energy from a single energy source such as natural gas, fuel oil, coal, or waste fuel such as wood refuse. However, the most popular energy sources for cogeneration are natural gas and diesel fuel. The cogeneration systems are more efficient than conventional energy systems because both the electric and thermal outputs are utilized. In conventional energy systems, the steam or hot water is produced in a boiler and the electricity is produced or purchased separately. The efficiency of a cogeneration unit is over 80 percent, compared with efficiencies in the range of 35 percent for a typical power generation plant (see Figure 1.2). Cost reductions associated with high efficiencies make packaged cogeneration systems economically attractive for Navy facilities where there is a thermal demand for domestic hot water (DHW), process steam, heating and cooling, and electrical consumption.

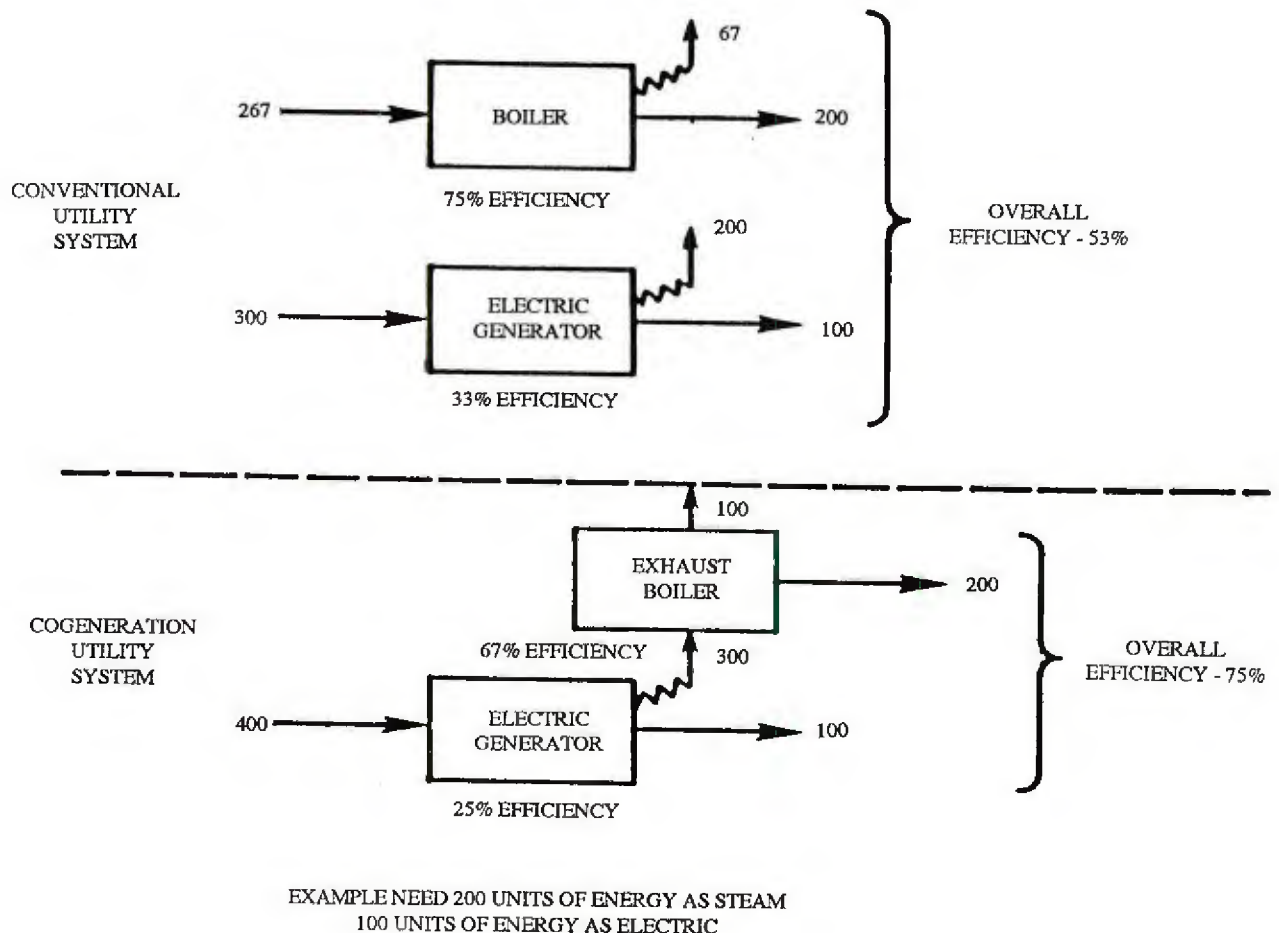

Figure 1.2 Efficiencies for Cogeneration and Power Generation Plants

The term "Packaged Cogeneration System (PCS)" refers to cogeneration systems which are pre-engineered and factory assembled and tested. PCSs are skid-mounted and are generally below 500 kW in capacity. PCSs have proved to be reliable because they are factory assembled from components that are manufactured in large quantities. Because the system is completely packaged at the factory, the installation cost is low compared with site-specific cogeneration systems. PCSs are also more compact and require less space than field-erected systems. All of these features have made PCS increasingly attractive to commercial and industrial users.

A PCS usually consists of a prime mover, such as a reciprocating engine or gas turbine, and heat recovery equipment that generates steam or hot water for domestic hot water, space heating, absorption cooling, or industrial process heat. A thermal energy storage device may also be added to the system to better utilize the waste heat and improve the cost savings.

A variety of hardware configurations are commercially available, as shown in Table 1.1. The internal combustion engines are designed to use either No. 2 diesel fuel or natural gas. Most of the natural gas-fired engines will also run on propane. The reciprocating engines used in cogeneration systems are generally very similar to automobile, marine, and truck engines. The experience gained from the manufacture of these engine types has led to the development of reliable, compact, and economical cogeneration systems. A schematic diagram of a typical cogeneration package with a reciprocating engine, synchronous generator, and heat recovery equipment is shown in Figure 1.3a. A gas turbine system with heat recovery is shown in Figure 1.3b. In Figure 1.4, a schematic of a typical PCS application is depicted.

Table 1.1 Small Cogeneration System Options

| Prime Movers | Fuels | Generator Sets | Heat Recovery |
|-----------------------|-------------|----------------|---------------------|
| Reciprocating Engines | Natural Gas | Induction | Heat Exchangers |
| Gas Turbines | Diesel Fuel | Synchronous | Driers |
| Steam Turbines | Gasoline | | Waste Heat Boilers |
| | Propane | | Absorption Chillers |

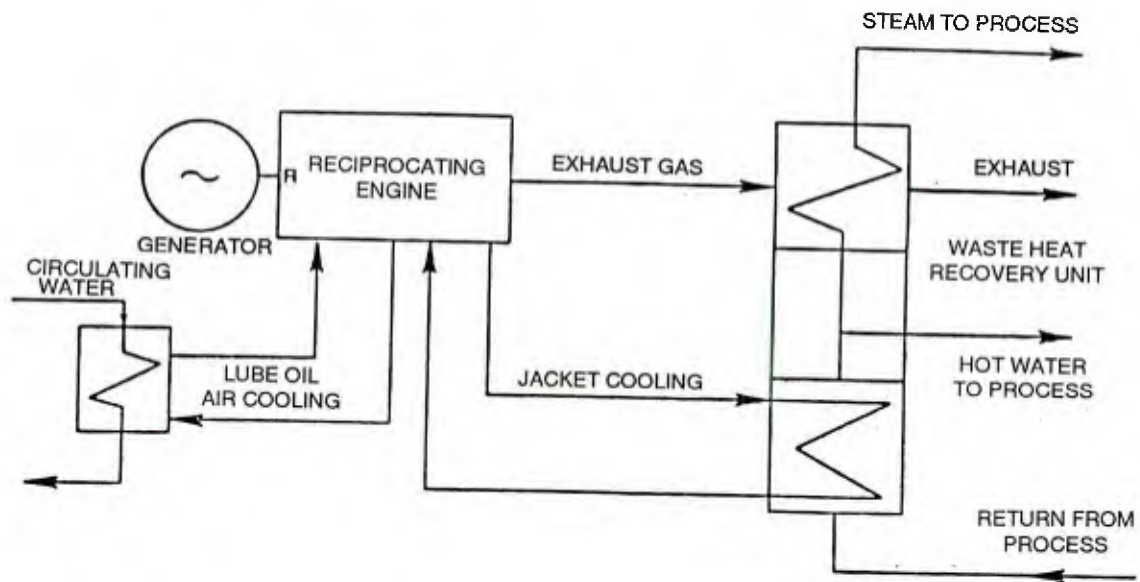

Figure 1.3a Reciprocating-Engine Cogeneration System

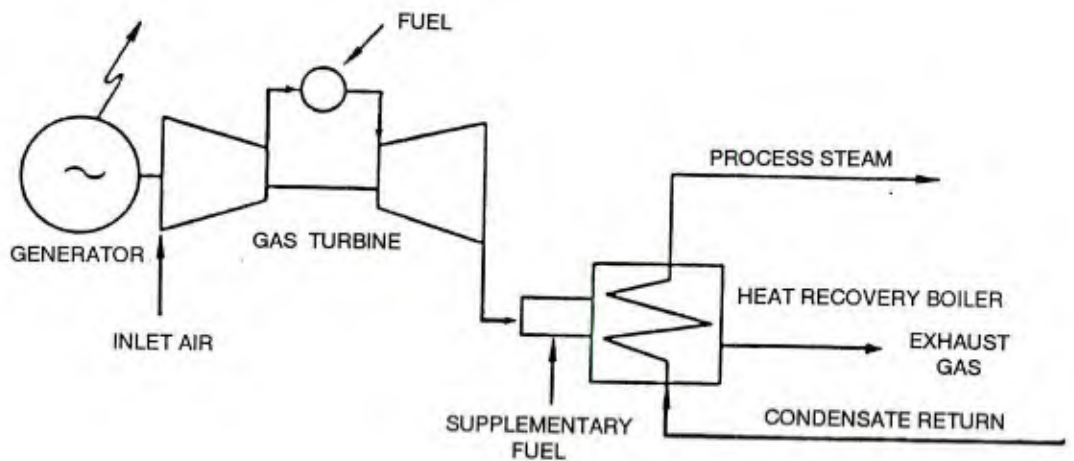

Figure 1.3b Gas Turbine With Heat Recovery Cogeneration System

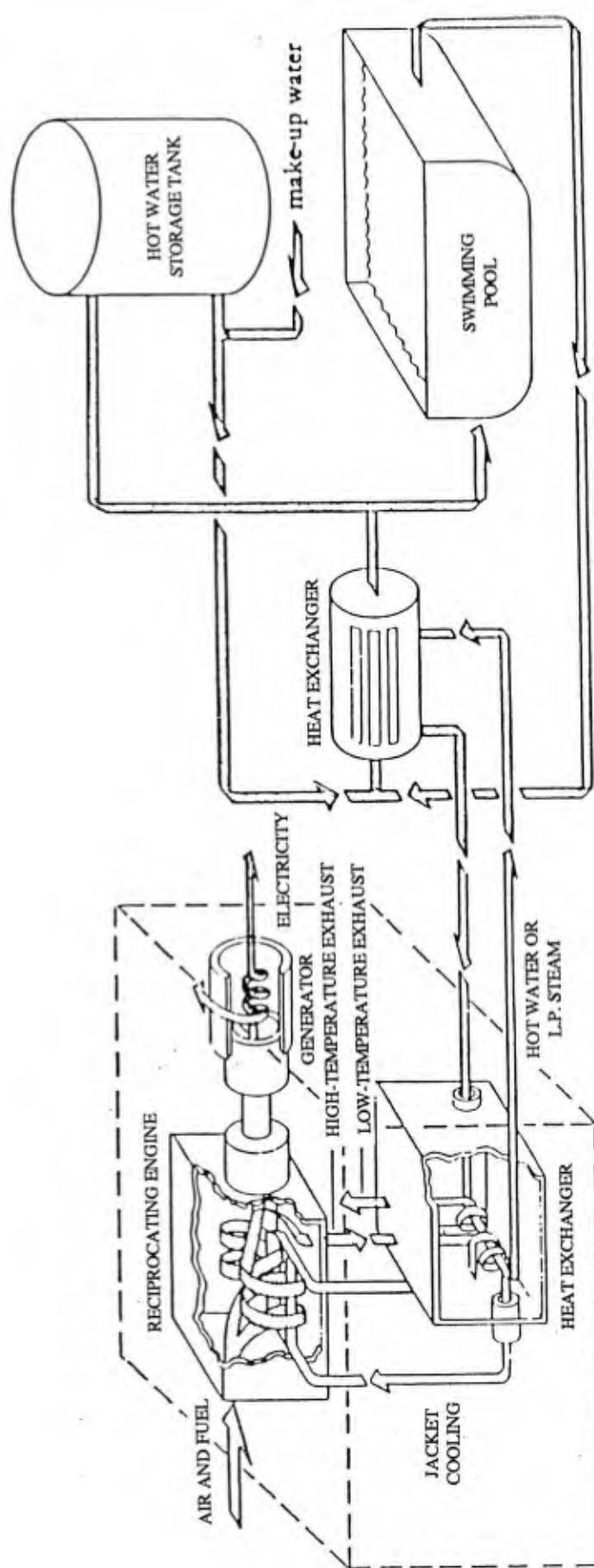

Figure 1.4 Schematic of a Typical PCS Application

The packaged cogeneration system (PCS) can be viewed as four interconnected submodules, as shown in Figure 1.4. The Engine Generator Submodule (EGS) consists of a reciprocating engine which drives a generator through a flywheel-mounted coupling. The engine drives the generator slightly above 1800 rpm, at which speed the generator starts delivering electricity to the Electrical Interface Submodule (EIS).

The main function of the EIS is to control the flow of electric power between the cogeneration unit and the electrical system of the facility where it is installed. The module also provides a number of other safety and control-related functions, such as engine cranking control, engine ignition control, battery charging, and natural gas valve control.

The Heat Transfer Submodule (HTS) includes equipment for recovering heat from the engine exhaust, jacket water, and lubricating oil. The return water from the thermal load flows first to the lube oil cooler because it is the lowest-temperature heat source. Next, it flows to the engine jacket cooler, then to the engine exhaust gas cooler, and finally through the exhaust manifolds before going to the external load. The heat exchanger used in the lube oil and the jacket water heat recovery are of the shell-and-tube type, whereas for the exhaust gas recovery a finned coil of copper tubing in a steel cylinder is used.

The Control Submodule (CS) (not shown in Figure 1.4) is a microprocessor-based system which starts the system when there is a demand for heat (or electricity) and shuts it down when the demand is satisfied. In addition, the CS monitors the output of a large number of sensors and shuts the system down if preset limits are exceeded.

Both induction and synchronous electrical generators are commercially available in packaged small cogeneration modules. Those systems with induction generators must rely on the electric utility line to supply power for excitation. The synchronous generator systems have the advantage of operation in a stand-alone mode. These generators operate in parallel with the electrical line frequency, are self-exciting, and can provide emergency power in the event of a blackout. The thermal output from the cogeneration unit can be used for providing domestic hot water, space heating, driving an absorption air-conditioning unit, or heating a swimming pool. The cogeneration unit can be thermally dispatched (thermal following mode) so that it will shut down automatically when there is no demand for hot water. The cogeneration unit can also be run at full capacity, in which case any excess thermal output is dumped to ambient in a radiator. The third mode in which a cogeneration unit can run is the electric following mode. In this case the cogeneration unit follows the electrical load; however, PCSs are not usually operated in this mode.

There is limited commercial experience with gas turbines in the power range of interest. This experience has been primarily with auxiliary power units used in airplanes and military generator sets. The advantages of using a gas turbine are as follows:

- a. Small size and weight
- b. Modularity/ease of maintenance
- c. High reliability

A list of the manufacturers of gas turbines for small cogeneration systems is given in Section V.

A third type of packaged cogeneration system (PCS) uses a steam turbine as the prime mover. There are very few applications of this type of system because steam turbines are not very efficient at the capacity range of interest. In addition, most small cogeneration system applications do not usually have a need for high-pressure steam. However, steam turbine cogeneration systems may be better suited than the other two types of systems to applications that require low-to-moderate-pressure steam (10 to below 100 psig). The steam turbine system can be used as a topping cycle with the exhaust steam being used for the thermal needs.

Steam turbine packaged systems come with both synchronous and induction generators. Like the gas engine driven PCS, the steam turbine PCS is integrated with control and utility tie-in modules. There is only one packager of this type of system, and the details are provided in Section V.

1.3 Small Cogeneration System Efficiency

The efficiency of a PCS is typically measured in one of the following three ways:

- Electric generating efficiency
- Heat production efficiency
- Overall efficiency

The electric generating efficiency is a measure of the engine efficiency. The thermal efficiency depends on the temperature at which the engine rejects its heat and the efficiency of the heat recovery equipment. These two efficiencies are inversely related; as the electric generating efficiency increases, the amount of recoverable heat decreases. The third number, the overall efficiency, is the sum of the electric and heat production efficiencies and can be as high as 85 percent.

Consider a hypothetical reciprocating engine-drive cogeneration module fed by 100 units/hour of fuel. The shaft output (to generator) is assumed to be 27 units/hour and the heat recovery (hot water) yields 54 units/hour. By the classic

definition of engine efficiency, this hypothetical module would be 27-percent efficient. However, the cogeneration efficiency equals the sum of both the shaft and heat outputs, or 81 percent.

The Federal Energy Regulatory Commission (FERC), in accordance with Section 201 of the Public Utility Regulatory Policies Act (PURPA) of 1978, requires an average, year-round efficiency of ≥ 42.5 percent (see Chapter 2, Regulatory Considerations). However, the FERC rules also require that the efficiency be calculated according to the relationship shown in Equation 1-1.

$$E = EE + (TE/2) \quad (1-1)$$

where E is the FERC-defined cogeneration efficiency,
EE is the electrical output as a percentage of
fuel energy input,
and TE is the used heat output as a percentage of fuel
energy input.

For the example described above, the cogeneration module would yield an efficiency of 54 percent ($E=27\%+54\%/2$) if the thermal output was used year-round. To solve for the fraction of time (F) that full heat recovery would have to be in effect to attain FERC qualifying status, Equation 1-2 would be used.

$$F = (42.5-EE) \times 2 / TE \quad (1-2)$$

For the previously described example, the module would satisfy FERC requirements if the available heat were fully used at least 57 percent of the time the engine was running, or if 57 percent of the recovered engine heat were stored.

Additional requirements for PURPA efficiency that pertain to topping and bottoming cycles are shown in Table 1.2.

1.4 Thermal Energy Storage (TES)

In many cases the economic viability of a small decentralized PCS depends on full utilization of the cogenerated heat. Because of the relatively low temperature of the heat produced by most small cogeneration systems, the heat must be used by the building at which the PCS is located. Except for cases in which the heat load is fairly constant, a thermal energy storage device is needed to act as a buffer between the steady output of the PCS and the variable heat load of the building.

Table 1.2 Operating Efficiency Standards for
PURPA Compliance

| Type of Facility | Operating Standards | Efficiency Standards |
|------------------|---|---|
| Topping Cycle | 5% of total energy output must be useful thermal energy | If thermal output is > 15%, power output plus one-half of thermal output must be at least 42.5% of annual oil and gas inputs. |
| | | If thermal output is < 15%, power output plus one-half of thermal output must be at least 45% of annual oil and gas inputs. |
| Bottoming Cycle | No operating standard | Useful power output must be at least 45% of annual oil and gas used for supplementary firing. |

Hot-water storage tanks are used to store the thermal energy. These tanks are available in a variety of sizes. The price of the tank is greatly influenced by whether or not the tank is pressurized or insulated. Most small cogeneration systems produce hot water at temperatures lower than 205 degrees F. Typical DHW applications require hot water at temperatures of 190 degrees F or lower. For this reason, vented nonpressurized tanks are adequate in most cases. Small cogeneration systems operate most efficiently with a thermal storage system equal to approximately three times the hourly thermal output of the cogeneration unit.

The thermal energy storage capacity of the hot-water storage tank is determined from the volume of the tank and the temperature differential between the stored water and the water supplied to the PCS. Approximately, one gallon of water can store 8.34 Btu for rising one degree F of water temperature. For example, if the water were supplied to the PCS at a temperature of 60 degrees F and stored at 180 degrees F, a 1000 gallon hot-water storage tank would have a capacity of approximately 1 MBtu (8.34 Btu/gal-F x 120 deg-F x 1000 gal).

1.5 PCS Applications and Market Potential

There are many applications in commercial and Navy sectors that have sufficient electric and thermal loads to make packaged cogeneration attractive. Since 1982, Gas Research Institute (GRI) has been working on developing and commercializing PCS technology for these applications (Ref 1). Several packaged systems ranging from 30 to 300 kW have been developed and tested for various applications. For applications where the hot-water demand is not large, the PCS can be integrated with an HVAC system, supplying electricity, heating, cooling, and domestic hot water simultaneously. The cooling provided by the PCS is generated by a hot-water-driven absorption chiller. As an HVAC option, cogeneration is particularly attractive in the new and retrofit markets where the cost of displaced HVAC equipment may be taken as a credit.

1.5.1 Commercial Applications and Market Potential

Some of the applications in the commercial sectors include apartment buildings, supermarkets, restaurants, hotels/motels, and hospitals. In all these applications there is sufficient thermal load (primarily hot water) and electric demand to make PCS economically feasible. In Table 1.3, a list of commercial PCS markets and an estimate of the number of potential applications is listed. This estimate was developed by the Gas Research Institute (GRI) from detailed research of the markets. Taken into account were various factors affecting the feasibility of cogeneration at a particular site, such as hours of operation per year, the heating, cooling, and electrical system efficiencies at various loads, the quality of heat, gas and electric prices, and grid interconnection requirements.

Table 1.3 Selected Commercial, Institutional, and Multi-unit Technically Feasible Sites (Ref 1)

| Applications | Potential Sites | Approximate kW Range |
|------------------------|-----------------|----------------------|
| Hospitals | 8,000 | 300 - 1000 |
| Restaurants | 20,000 | 50 - 80 |
| Supermarkets | 28,000 | 90 - 120 |
| Multifamily Dwellings | 50,000 | 50 - 100 |
| Hotels/Motels | 7,000 | 100 - 2000 |
| Shopping Centers | 8,000 | 500 - 1500 |
| Educational Facilities | 13,000 | 500 - 1500 |
| Large Offices | 25,000 | 500 - 2000 |
| Total | 159,000 | |

Several PCSs were specifically developed for particular commercial applications. GRI has developed and tested three packages for hospitals, supermarkets, and restaurant applications. The one for hospitals is a 500 kW cogeneration package with a 150 ton absorption chiller. The restaurant package is a 70 kW unit with a 35 ton chiller. The supermarket unit is a 97 hp gas engine driving a 10 ton mechanical chiller.

A recent study by the Electric Power Research Institute (EPRI) showed that there are over 600 applications where small PCSs are being used (Ref 2). A distribution of these by geographical regions is shown in Table 1.4. A facility type distribution of these systems is shown in Table 1.5. A majority of these systems are under 500 kW; however, about 150 systems are over 500 kW. The systems that are over 500 kW are mostly multiple-unit systems, with each unit being under 500 kW in capacity. A distribution of the system capacity and the number of systems is shown in Table 1.6. There are over a dozen packagers represented among these 600 systems; a list of these is shown in Table 1.7.

Table 1.4 Distribution of PCS Installations by Geographical Area (Ref 2)

| State | Number of Systems |
|--|-------------------|
| California | 306 |
| Massachusetts | 56 |
| New Jersey | 51 |
| New York | 34 |
| Connecticut | 30 |
| Michigan | 18 |
| Pennsylvania | 16 |
| Hawaii | 10 |
| Maine | 9 |
| Iowa, Texas | 8 each |
| Arizona | 7 |
| Ohio, Utah | 6 each |
| Rhode Island | 5 |
| Florida, Vermont | 4 each |
| Illinois, Kansas, Nebraska, Virginia | 3 each |
| New Hampshire, New Mexico | 2 each |
| Arkansas, Colorado, Mississippi, Missouri | 1 each |
| Nevada, Puerto Rico, South Carolina, Tennessee | 1 each |
| Total | 602 |

Table 1.5 Distribution of PCS Installations by Building Type (Ref 2)

| Type of Facility | Number of Systems |
|--------------------------|-------------------|
| Apartment | 32 |
| College | 38 |
| Farm | 9 |
| Gov/Pub/Mun/Sewage-Plant | 39 |
| Hospital | 48 |
| Hotel | 60 |
| Industrial | 98 |
| Laundry | 19 |
| Nursing Home | 39 |
| Office | 17 |
| Recreational | 51 |
| Restaurant | 18 |
| Retail | 3 |
| Residential | 9 |
| School | 41 |
| Supermarket | 1 |
| Unknown | 79 |
| Total | 602 |

Table 1.6 Distribution of PCS Installations by Capacity (Ref 2)

| Capacity (kW) | Number of Systems |
|---------------|-------------------|
| 1 - 10 | 48 |
| 11 - 50 | 42 |
| 51 - 100 | 178 |
| 101 - 200 | 93 |
| 201 - 500 | 88 |
| 501 - 1000 | 67 |
| Over 1000 | 62 |
| Unknown | 21 |
| Total | 602 |

Table 1.7 Distribution of PCS Installations by
Manufacturer/Packager (Ref 2)

| Manufacturer/Packager | Number of Systems |
|-----------------------|-------------------|
| American M.A.N. | 9 |
| ASK, Inc. | 3 |
| Caterpillar | 23 |
| CFM | 5 |
| Cogenic | 28 |
| Cummins | 2 |
| Hawthorne | 25 |
| ICC | 5 |
| Martin Cogeneration | 4 |
| Micro Cogen | 10 |
| Solar Turbine | 2 |
| Tecogen | 161 |
| Thermex | 26 |
| Waukesha | 33 |
| Other | 48 |
| Unknown | 218 |
| Total | 602 |

1.5.2 Navy PCS Applications and Market Potential

There are several types of Navy facilities where PCS can be beneficial, including bachelor officer/enlisted quarters, dining facilities, hospitals, laundry facilities, and industrial facilities. Any facility that meets the following conditions is considered as a possible candidate for small cogeneration:

- Relatively high electric-to-fuel cost differential of \$15/MBtu or higher
- A thermal load of at least 100,000 Btu/hr (equivalent to the electrical output of a 20kW cogeneration unit) for a minimum of 4,000 hours of operation per year

The electric-to-fuel cost differential is calculated as shown in the following example:

Electricity at \$0.10/kWh is equal to \$29.3/MBtu
(using 3413 Btu/kWh).

Natural gas at \$0.60/therm is equal to \$6/MBtu
(using 100,000 Btu/therm).

The cost differential between electricity and fuel is therefore

$$\$29.3/\text{MBtu} - \$6/\text{MBtu} = \$23.3/\text{MBtu}$$

The market potential for many Navy facilities is excellent. A recently completed survey of over 600 Naval activities identified 507 PCS candidate facilities. Data for the survey were obtained from the Naval Facilities Assets and Master Activity General Information Code (NFA/MAGIC) data bases and the Defense Energy Information System (DEIS II). An analysis was performed for all Navy offices, stores, hospitals, educational facilities, multifamily residences, BOQ/BEQ, laundries, dining facilities, and swimming pools. PCS candidate facilities were determined based on the following criteria:

- A thermal load of at least 100,000 Btu/hr
- An electric-to-fuel cost differential of \$15/MBtu or higher

The results of the PCS candidate analysis by facility type are shown in Table 1.8. A complete listing of facility candidates is provided for reference in Appendix A.

Table 1.8 Number of PCS Candidates by Facility Type

| Facility Type | Number of Facilities |
|-----------------------------|----------------------|
| Offices | 150 |
| Stores | 0 |
| Hospitals | 23 |
| Educational Facilities | 67 |
| Multifamily Residences | 145 |
| Enlisted Personnel Quarters | 38 |
| Laundries | 0 |
| Dining Facilities | 81 |
| Swimming Pools | 3 |
| Total | 507 |

Facility types that should be considered as potential candidates for PCS are listed in Table 1.9. Additional considerations that should be evaluated are also shown for each type of facility. The thermal consumptions per unit area for each facility were obtained from an EPRI study (Ref 3) and are also shown in Table 1.9.

Table 1.9 Additional Facility Types Appropriate for PCS

| Facility Type | Considerations | Thermal Use (kBtu/ft ²) |
|--|---|-------------------------------------|
| Hospital | New or renovated facilities. | 110 |
| College/University | Should be operated year-round to be considered. | 34 |
| BOQ/BEQ | Need good year-round occupancy. Facilities with laundries, air conditioning, or other thermal load requirements are best candidates. | 64 |
| Commissary | Must have continuous thermal load to be cost effective. | 47 |
| Office | Facilities with large computers are generally good candidates. | 32 |
| Mess Halls/ Officers Clubs | The following conditions must be met: (1) two or three meals are served a day; (2) the restaurant is operated six or seven days per week; (3) the restaurant is busy year-round. | 108 |
| Laundry | Small facilities may not have a large enough electric demand to be cost effective. | 50 |
| Multifamily Housing | New apartments are good candidates in areas with continuous thermal loads. Older buildings with individual DHW heaters, space heating, and cooling systems are generally not good candidates. | 55 |
| Recreational Facility | Facilities with a heated pool or spa are excellent candidates. | 400 |
| Industrial Facility | Any industrial shop with a continuous thermal requirement (e.g., process steam and hot water). | (1) |
| (1) Depends on type of industrial facility | | |

The Navy is currently involved with three PCS applications; one is located at the U.S. Naval Station Treasure Island, CA and two are currently being installed at the Marine Corps Base, Camp Pendleton, CA.

1.5.3 Treasure Island Packaged Cogeneration System

A small cogeneration unit has been installed in Building 261 at Naval Station Treasure Island, CA for use in heating a swimming pool and shower storage tank. The system was purchased and installed by Pacific Gas and Electric Company under an agreement with the Navy as part of a three-year research and development program. The performance of the cogeneration system is being monitored by the Department of Engineering Research of PG&E through a microprocessor remote monitoring system.

The cogeneration module monitored at Treasure Island is a 60kW unit commercially manufactured by TECOGEN. The thermal output of the unit is rated at 440,000 Btu/hr. Performance data for the first twelve months of operation showed that the unit operated at an electrical efficiency of between 26 and 27 percent. The thermal efficiency was between 54 and 58 percent. A net annual energy saving of 2,805 MBtu was realized, which resulted in a net annual cost saving of about \$8,000 (assuming a maintenance cost of \$1 for every hour of operation). Detailed information on this PCS and operational data during the period from September 1987 to August 1988 are provided in Appendix B.

1.5.4 Camp Pendleton Packaged Cogeneration Systems

Two 30kW PCS units commercially manufactured by TECOGEN are currently being installed at the Marine Corps Base Camp Pendleton, CA. These prepackaged natural-gas-driven cogeneration systems have thermal delivery rates of 219,000 Btu/hr and will be used in BEQ buildings 1396, 1397, and 1398 and in Mess Hall 13100 to supply domestic hot water.

II. Planning

2.1 Overview

This chapter contains recommended changes to NAVFAC Planning (P) Publications, including "Department of the Navy Facility Category Codes" (P-72) and "Facility Planning Factor Criteria for Navy and Marine Corps Installations" (P-80). These documents are used by Navy planners to estimate the Basic Facility Requirement at an activity.

This chapter also includes information to assist planners evaluate the technical and economic feasibility of PCSs at Navy facilities. A methodology is provided which can be used to estimate the following information:

- Average daily and hourly DHW load
- Total cogeneration heat used
- Total cogeneration heat vented
- Fraction of the thermal load met by cogeneration
- Electrical savings
- Annual cost savings for PCS operation
- Savings-to-investment ratio
- Simple payback period

Computer programs that will assist the planner with the technical and economic feasibility evaluation are also discussed in detail.

In addition to establishing technical and economic feasibility, Navy planners must consider permit requirements for PCS installation. The Planning Chapter also contains a discussion of local building code permits, state permits, the Federal Regulatory Commission's (FERC's) Qualified Facility (QF) form, and environmental permits for pollution abatement.

The final section of this chapter provides information about financing options available to Navy planners. A discussion of the following is included:

- Navy owned and operated
- Third-party development and operation
- Navy owned/third-party built and operated

2.2 Recommended Modifications to NAVFAC P-Publications

2.2.1 Input to NAVFAC P-72

The following addition to page 77 of NAVFAC P-72, "Department of the Navy Facility Category Codes," April 1984, is recommended:

CATEGORY CODES FOR MILITARY REAL PROPERTY

| CATEGORY CODE | FAC TYPE | UNITS OF MEASURE | | NOMENCLATURE (AND DESCRIPTIVE NOTES) | MAINT COST ACCT | INVST CAT | FAC REQ REPORT INDICA |
|---------------|----------|------------------|-----------|---|-----------------|-----------|-----------------------|
| | | AREA | OTHER ALT | | | | |
| 800 | | | | UTILITIES AND GROUND IMPROVEMENTS | | | |
| 810 | | | | ELECTRIC POWER | | | |
| 811 | | | | ELECTRIC POWER SOURCE | | | |
| | | | | Plant building and equipment including generating units and prime mover (turbines/engines), condensers, auxiliary equipment, plant switching stations and transformers (in/adjacent/near and directly connected to plant), and connected tanks/bins holding day-to-day fuel requirements. Do not report KW for buildings. | | | |
| 811 - 00 | | | (KW) | ELECTRIC POWER, SOURCE | | 17 | |
| | | | | This is a pseudo category code. Do not use for inventory purposes. Use only for BFR purposes to indicate the seven-year projection of peak demand for electric energy to satisfy the mission of the activity responsible for providing electricity. | | | |
| 811 - 09 | BLDG | (SF) | | ELECTRIC POWER PLANT BUILDING | 7610 | 17 | |
| 811 - 10 | UTIL | | (KW) | ELECTRIC POWER PLANT-DIESEL | 7610 | 17 | NO |
| 811 - 25 | UTIL | | (KW) | ELECTRIC POWER PLANT-STEAM | 7610 | 17 | NO |
| 811 - 30 | UTIL | | (KW) | PACKAGED COGENERATION SYSTEM (PCS) | 7610 | 17 | NO |
| 811 - 45 | UTIL | | (KW) | ELECTRIC POWER PLANT-GAS TURBINE | 7610 | 17 | NO |
| 811 - 59 | BLDG | (SF) | | STAND-BY GENERATOR BUILDING | 7610 | 7 | NO |
| 811 - 60 | UTIL | | (KW) | STAND-BY GENERATOR PLANT | 7610 | 17 | NO |

2.2.2 Input to NAVFAC P-80

The recommended addition to section 811 of NAVFAC P-80, "Facility Planning Factor Criteria for Navy and Marine Corps Installations," October 1982, is as follows:

811 10 - 811 45 ELECTRIC POWER PLANTS

Consideration as to whether an electric power generating plant is to be planned will depend on the station's geographical location, the availability of a reliable, uninterrupted adequate power supply from a local electric utility, the economics of using by-product steam for space heating and industrial process work, and the availability of the required fuel. Consideration should also be given to the use of packaged cogeneration systems (PCSs) which satisfy both electric and thermal requirements in individual facilities or small building complexes. PCS units can supply excess electricity back to the grid. When planning a PCS installation, facilities with high electric-to-thermal cost differentials and a consistent year-round thermal requirement should be considered. The electric generating plant (diesel or steam) shall have a total installed capacity equal to the station's total kilowatt demand. In the case of diesel generators, there must be one additional standby generating unit with a capacity equal to the largest unit on line. In the planning and determination of power plant capacity, due consideration should be given to the estimated demand of all of the station's consumption, both electrical and industrial, plus the anticipated load growth. The estimated structures are shown on the definitive drawings in Definitive Designs, NAVFAC P-272. For initial planning purposes, power plant capacity may be computed by either (1) utilizing the factors indicated under 810 above, or (2) totaling all of the estimated demands in kilowatts of all existing and proposed station buildings, as shown on the definitive drawings, and multiplying this total by an appropriate diversity factor. Where a diversity factor is not provided, a factor of eighty percent (80%) may be used. The resultant total is the estimated power plant capacity, or the estimated amount of electrical power needed by the station facilities. See Definitive Designs, NAVFAC P-272, Part 2 for various types and sizes of electrical power plants. See NAVFAC DM-4, Electrical Engineering for design information.

2.3 PCS Feasibility

A successful feasibility analysis will consider all of the major engineering elements, including thermal and electrical use, sizing of basic plant configuration, utility availability, regulatory considerations, and economics.

All the components used in packaged cogeneration systems are of proven technology. These systems have been used successfully at over 600 sites during the last five years. Therefore, the primary issues of concern during the PCS feasibility study are site-related, regulatory, economic, and RAM related.

2.3.1 Technical Feasibility Assessment

The thermal load is the primary determining factor for establishing the feasibility of using a PCS in a building or complex. Rough engineering estimates can be established using accepted engineering data such as ASHRAE Standards. More actual information may be obtained through the direct metering of the candidate facilities. Although the thermal energy produced by a PCS unit may be used for space heating, space cooling, and domestic hot water (DHW), the consistent and relatively large thermal load profile associated with DHW makes it the best use of cogenerated heat. Also, the cost of the auxiliary equipment needed to produce and store DHW is generally less expensive than the equipment associated with space heating and cooling. For these reasons, the technical and economic assessment method discussed in this chapter assumes that the cogenerated heat will be used for DHW.

The technical assessment procedure for small cogeneration involves data collection, DHW load analysis, and system selection. In the first step, the individual performing the analysis is required to collect information such as DHW usage, fuel type availability, water temperatures, and thermal efficiency. The data shown in Table 2.1 are required to perform the PCS feasibility analysis. Data collection forms are included in Appendix C.

In the second step, the DHW load profile is determined from data collected at the facility. Once load patterns are established for the facility, energy calculations are performed for a one-week period and the following values are estimated:

- a. Average daily and hourly DHW load
- b. Total cogeneration heat used
- c. Total cogeneration heat vented
- d. Fraction of the thermal load met by cogeneration

The DHW load calculations involve a simulation of the hourly DHW usage and cogenerated heat supply. The cogenerated heat that is

not needed for DHW is stored. When the hot-water storage tank is at capacity, the cogenerated heat is vented. Following the thermal calculations, a PCS is selected for economic analysis.

Table 2.1 Data Requirements for Feasibility Analysis

| Description | Variable Name |
|--|--------------------|
| DHW Usage Weekday, gal/hr Weekend, gal/hr | DHWwd DHWwe |
| Fuel Type and Rate Natural Gas (cuft/hr) Diesel Fuel (gal/hr) | RATEng RATEdf |
| Water Temperatures Minimum Hot Water, °F Maximum Hot Water, °F Cold Water, °F | Tmin Tmax Tc |
| Thermal Storage Capacity, gal | GAL |
| Annual Operating Hours, hr | ANOPHRS |
| Existing Thermal Efficiency, % | SYSEFF |

The simulation requires an estimate of the DHW load profile for a typical weekday and weekend. Using the form in Appendix C, average hourly DHW data for the facility being analyzed should be measured and totaled for a typical weekday and weekend for a 24-hour period.

Once the hourly DHW load profiles have been estimated, the average hourly thermal load must be estimated using the weekday and weekend DHW totals and Equations 2-1 and 2-2. The weekday and weekend DHW usage daily totals are estimated by summing the hourly values as shown in Appendix C.

$$\text{DHWTOT} = 5 \cdot \text{DHWTOTwd} + 2 \cdot \text{DHWTOTwe} \quad (2-1)$$

$$\text{DHWAVG} = (\text{DHWTOT} \cdot ((\text{Tmax} - \text{Tmin}) / 2 - \text{Tc}) \cdot 8.34) / (168000) \quad (2-2)$$

where DHWTOT is the total weekly DHW usage in gallons,
 DHWTOTwd is the total weekday DHW usage in gal/day,
 DHWTOTwe is the total weekend DHW usage in gal/day,
 DHWAVG is the average hourly DHW load in kBtu/hr,
 Tmax is the maximum hot-water temperature in deg F,
 Tmin is the minimum hot-water temperature in deg F,
 and Tc is the inlet cold water temperature in deg F.

Once the average hourly DHW load (DHWAVG) has been estimated, a small cogeneration system may be selected for analysis. Any of the units shown in Table 5.1 or any unit for which the following information is available may be selected for the economic analysis:

- a. PCS Module Performance Data
 - Thermal Output, CGHO (kBtu/Hr)
 - Maintenance Factor, MNTFAC (decimal)
 - Fuel Rate, RATE (cuft/hr for natural gas, gal/hr
for diesel fuel or propane)
 - Generator Type
- b. PCS Module Cost Data
 - Maintenance Cost, MNTCST (\$/kWh)

A system should be selected that has the correct fuel type and generator type and has a thermal output less than or equal to the average hourly thermal load (DHWAVG). The system with the largest thermal output that is less than or equal to the average hourly thermal load will generally yield the best return on investment and should be selected. The data for the selected PCS unit to be analyzed may be entered in the data collection forms shown in Appendix C.

Small cogeneration systems operate most efficiently with a thermal storage system equal to approximately 3 times the hourly thermal output of the cogeneration unit (CGHO). Use Equations 2-3, 2-4, and 2-5 to estimate the additional storage required.

$$\text{HRS} = (\text{GAL} * 8.34 * ((\text{Tmax} + \text{Tmin}) / 2 - \text{Tc})) / (\text{CGHO} * 1000) \quad (2-3)$$

If HRS is greater than or equal to 3;

$$\text{ADDTS} = 0. \quad (2-4)$$

If HRS is less than 3;

$$\text{ADDTS} = ((3 - \text{HRS}) * \text{CGHO} * 1000) / (8.34 * ((\text{Tmax} + \text{Tmin}) / 2 - \text{Tc})) \quad (2-5)$$

where HRS is the number of hours of existing storage (hr.),
 GAL is the existing hot-water storage capacity (gal),
 Tmax is the maximum hot-water temperature (deg F),
 Tmin is the minimum hot-water temperature (deg F),
 Tc is the inlet cold-water temperature (deg F),
 CGHO is the cogeneration unit thermal output (kBtu/hr),
 and ADDTS is the additional thermal storage required (gal).

Once the additional storage capacity is determined, the total capacity of the hot-water storage system is determined using Equation 2-6.

$$MCST = GAL + ADDTS \quad (2-6)$$

where MCST is the total capacity of the storage (gal),
 GAL is the existing hot-water storage capacity (gal),
 and ADDTS is the additional thermal storage required (gal).

After the storage capacity (MCST), cogeneration unit thermal output (CGHO), and hourly DHW load profiles have been estimated, the total cogenerated heat used, the total cogenerated heat vented, the total backup heat required, and the fraction of load met by cogenerated heat are calculated.

The simulation is performed for seven 24-hour periods; in the first five periods, weekday DHW profiles are used and in the last two periods the weekend DHW profiles are used. By following Steps 1 through 5, the cogeneration system's weekly performance will be simulated.

Step 1 - Calculate the average temperature differential (TDIF).

$$TDIF = (Tmin+Tmax)/2-Tc \quad (2-7)$$

where TDIF is the average storage temperature differential,
 TDIF (deg F),
 Tmax is the maximum hot-water temperature (deg F),
 Tmin is the minimum hot-water temperature (deg F),
 and Tc is the inlet cold-water temperature (deg F).

**Step 2 - Initialize TS equal to Tmin; QBU and QLOST equal to 0;
 Day equal to 1 (Monday); Hour equal to 1 (2400 to 0100).**

TSold = Tmin
 QBUold = 0
 QLOSTold = 0
 Day = 1
 Hour = 1

where TSold is the initial thermal storage temperature (deg F),
 QBUold is the initial auxiliary heat required to maintain
 the storage tank at a temperature above Tmin
 (kBtu/wk),
 QLOSTold is the initial amount of vented cogenerated heat
 required to limit the storage tank at a temperature
 below Tmax (kBtu/wk),
 Day is the day of the simulation (e.g., Day 1 is Monday),
 and Hour is the hour of the simulation (e.g., Hour 1 is
 2400-0100 hours)

Step 3 - Calculate the hot-water storage temperature (TS).

$$TS_{\text{new}} = TS_{\text{old}} + (CGHO - DHW(\text{Day}, \text{Hour}) * TDIF * 8.34 / 1000) / (MCST * 8.34 / 1000) \quad (2-8)$$

where TSnew is the new thermal storage temperature after the
 hour is completed (deg F),
 TSold is the old thermal storage temperature at the start
 of the hour (deg F),
 CGHO is the cogeneration module heat output (kBtu/hr),
 DHW(Day, Hour) is the DHW used on the given day for the
 specified hour (gal),
 TDIF is the average temperature differential (deg F),
 and MCST is the total capacity of the thermal storage tank
 (gal).

If TSnew is less than Tmin, go to Step 4.
 If TSnew is greater than Tmax, go to Step 5.

**Step 4 - Calculate the auxiliary heat required to maintain the
 thermal storage tank at a temperature above Tmin (QBU).**

$$QBUnew = QBUold + MCST * (Tmin - TSnew) * 8.34 / 1000 \quad (2-9)$$

where QBUnew is the new total auxiliary heat required to
 maintain the thermal storage tank at a temperature
 above Tmin (kBtu/wk),
 QBUold was the previous total auxiliary heat required to
 maintain the thermal storage tank at a temperature
 above Tmin (kBtu/wk),
 MCST is the total capacity of the thermal storage tank
 (gal),
 Tmin is the minimum hot water temperature (deg F),
 and TSnew is the thermal storage tank temperature (deg F).

Continue to Step 6.

Step 5 - Calculate the amount of vented cogenerated heat required to limit the temperature of storage to Tmax, QLOST.

$$QLOST_{new} = QLOST_{old} + MCST \cdot (TS_{new} - T_{max}) \cdot 8.34 / 1000 \quad (2-10)$$

where $QLOST_{new}$ is the new total vented cogenerated heat (kBtu/wk),
 $QLOST_{old}$ is the previous total vented cogenerated heat (kBtu/wk),
 $MCST$ is the total capacity of the thermal storage tank (gal),
 T_{max} is the maximum hot water temperature (deg F),
and TS_{new} is the thermal storage tank temperature (deg F).

Step 6 - Increment the hour and day if needed and proceed to Step 3 to continue the simulation for the next hour.

Increment Hour by 1.

If Hour is greater than 24, set Hour equal to 1 and increment Day by 1. If the new value of Day is equal to 8, discontinue simulation and proceed to Step 7. Otherwise, return to Step 3 and continue the simulation with the new values of Hour and Day.

Step 7 - Calculate the total backup heat required (QBU), the total cogenerated heat used (QUCGHT), the total cogenerated heat vented (QLOST), and the fraction of the load met by cogenerated heat (LFCG).

$$QBU = QBU_{new}$$

$$QLOST = QLOST_{new}$$

$$QUCGHT = CGHO \cdot 168 - QLOST \quad (2-11)$$

$$LFCG = 1 - QBU / (DHWTOT \cdot TDIF \cdot 8.34) \quad (2-12)$$

where QBU is the total backup heat required per week (kBtu/wk),
 QBU_{new} is the backup heat value taken from the result of Step 4 (kBtu/wk),
 $QLOST$ is the total vented cogenerated heat per week (kBtu/wk),
 $QLOST_{new}$ is the value for vented cogenerated heat taken from the result of Step 5 (kBtu/wk),
 $QUCGHT$ is the usable heat output by the cogeneration module per week (kBtu/wk),
 $CGHO$ is the cogeneration module thermal output (kBtu/hr),
 $LFCG$ is the fraction of thermal load met by cogeneration,
 $TDIF$ is the average thermal storage temperature differential (deg F),
and $DHWTOT$ is the total DHW usage for a week (gal/wk).

2.3.2 Economic Feasibility Assessment

In addition to the results of the simulation, the following data are needed to perform an economic analysis for the small cogeneration system:

- a. Electrical demand cost, DEMCST (\$/kW)
- b. Electrical energy cost, ELECST (\$/kWh)
- c. Anticipated annual operating hours, ANOPHR (hr)
- d. Heating system fuel cost, SFCST (\$/MBtu)
- e. Heating system thermal conversion efficiency, SYSEFF (decimal)
- f. Heating system fuel cost, SFCST (\$/MBtu),
- g. Cogeneration module maintenance cost, MNTCST (\$/kWh)
- h. Cogeneration module maintenance factor, MNTFAC (decimal)

The following data are also necessary for performing the economic analysis; however, methods for estimating these values are provided in the event that actual data are not available.

- a. Electrical output of the cogeneration module, CGEO (kW)
- b. Cogeneration module fuel consumption, FULCON (kBtu/hr)
- c. Cogeneration module capital cost (including equipment, installation, and thermal storage costs), CAPCST (\$)
- d. Uniform present worth discount factors (adjusted for fuel price escalation), UPW (-)
- e. Discount rate, R (%)
- f. Useful life, N (yr)

The tables in Appendix C are useful for organizing the information needed in the final calculations of the economic analysis. Methods for estimating unknown values are also discussed in appendix C. Once the data are assembled, the calculations shown in Equations 2-13 through 2-21 are performed to complete the analysis. A simplified procedure for determining a rough estimate for the economic parameters is also provided in Appendix C.

$$\text{OPHRS} = \text{ANOPHR} * (1 - \text{MNTFAC}) \quad (2-13)$$

$$\text{ELES AV} = \text{DEMCST} * \text{CGEO} * 12 + \text{ELECST} * \text{OPHRS} * \text{CGEO} \quad (2-14)$$

$$\text{FULSAV} = (\text{QUCGHT} * \text{OPHRS} * \text{SFCST}) / 168000 \quad (2-15)$$

If the fuel type is natural gas;

$$\text{FULCON} = \text{RATE} * 1.06 \quad (2-16a)$$

If the fuel type is diesel fuel;

$$\text{FULCON} = \text{RATE} * 137.31 \quad (2-16b)$$

If the fuel type is propane;

$$\text{FULCON} = \text{RATE} * 95.5 \quad (2-16c)$$

$$\text{FULLOS} = \text{FULCON} * \text{CFCST} * \text{OPHRS} / 1000 \quad (2-17)$$

$$\text{MNTLOS} = \text{MNTCST} * \text{CGEO} * \text{OPHRS} \quad (2-18)$$

$$\text{OPMTC} = \text{FULLOS} + \text{MNTLOS} \quad (2-19)$$

$$\text{ANSAV} = \text{ELES AV} + \text{FULSAV} - \text{OPMTC} \quad (2-20)$$

$$\text{SIR} = (\text{ELES AV} * \text{UPWe}(\text{R}, \text{N}) + (\text{FULSAV} - \text{FULLOS}) * \text{UPWf}(\text{R}, \text{N}) - \text{MNTLOS} * \text{UPW}(\text{R}, \text{N})) / \text{CAPCST} \quad (2-21)$$

$$\text{SPB} = \text{CAPCST} / \text{ANSAV} \quad (2-22)$$

where ANOPHR is the anticipated annual number of operating hours before maintenance (hrs),
 ANSAV is the total annual savings incurred for cogeneration module operation (\$/yr),
 CAPCST is the capital cost of the cogeneration equipment, including installation and the cost for additional thermal storage (\$),
 CFCST is the cogeneration module fuel cost (\$/MBtu),
 CGEO is the electrical output (kW),
 DEMCST is the electrical demand cost (\$/kW),
 ELECST is the electrical energy cost (\$/kWh),
 ELES AV is the total annual electrical savings from the operation of the cogeneration module (\$/yr),
 FULCON is the cogeneration module fuel consumption rate (kBtu/hr),
 FULLOS is the annual cogeneration module fuel cost (\$/yr),
 FULSAV is the displaced fuel cost of existing heating system resulting from cogeneration module operation (\$/yr),
 MNTCST is the cogeneration module maintenance cost (\$/kWh),
 MNTFAC is the maintenance factor (e.g., A factor of 0.10 implies that the unit is being serviced 10% of its operating life.)
 MNTLOS is the annual maintenance cost (\$/yr),
 OPHRS is the annual number of operating hours after downtime due to maintenance (hrs),
 OPMTC is the cogeneration O&M cost (\$/yr),
 QUCGHT is the usable heat output by the cogeneration module (kBtu/wk),
 RATE is the cogeneration module fuel consumption rate (cuft/hr for natural gas or gal/hr for diesel fuel or propane),
 SFCST is the existing heating system fuel cost (\$/MBtu),
 SIR is the savings-to-investment ratio,
 SPB is the simple payback period for the cogeneration module (yr),
 UPW(R,N) is the Uniform Present Worth Discount Factor for discount rate R and useful life N,
 UPWe(R,N) is the Uniform Present Worth Discount Factor adjusted for electricity price escalation for discount rate R and useful life N,
 and UPWf(R,N) is the Uniform Present Worth Discount Factor adjusted for fuel price escalation for discount rate R and useful life N.

2.3.3 Computer Software

A variety of software products are available to assist the planner in evaluating the performance and economic savings potential of cogeneration energy systems. Table 2.2 lists the programs and provides a point of contact and pricing information.

Table 2.2 Cogeneration Analysis Software

| Program Name | Point of Contact | Price |
|---|---|-------------------|
| Small Cogeneration Analysis Program (SCAP) | Dr. Richard Lee Naval Civil Engineering Laboratory, Code L74 Port Hueneme, CA 93043 (805)982-1670 (Comm) 551-1670 (Autovon) | Public Domain |
| Civil Engineering Laboratory Cogeneration Analysis Program (CELCAP) | Dr. Richard Lee Naval Civil Engineering Laboratory, Code L74 Port Hueneme, CA 93043 (805)982-5426 (Comm) 551-1670 (Autovon) | Public Domain |
| Dual Energy Use Systems (DEUS) | National CSS Marina Playa Executive Park 1333 Lawrence Expressway Santa Clara, CA 95051 (408)249-9500 | Nominal |
| Cogeneration Options Evaluation (COPE) Program | EPRI Palo Alto, CA 94303 (415)855-2420 | Nominal |
| Associated Cogeneration Analysis (ACE) | William Stieglemann Associated Utilities Services, Inc. 155 Gaither Drive P. O. Box 650 Moorestown, NJ 08057 (609)234-9200 | \$800- \$1,300 |
| Cogeneration Feasibility Analysis Model (CFAM) | Paul Hutchins Reynolds, Smith and Hills P. O. Box 4850 Jacksonville, FL 32201 (904)739-2000 | \$1,700 |

Table 2.2 Cogeneration Analysis Software (Cont.)

| Program Name | Point of Contact | Price |
|---|---|------------------|
| Cogeneration Feasibility Analysis System (CFAS) | David Koenigfisher Integrated Energy Systems 307 N. Columbia Street Chapel Hill, NC 27514 (919)942-2007 | \$1,250 |
| COGENMASTER | Hans Gransell EPRI Palo Alto, CA 94304 (415)855-2411 | Nominal |
| Cogeneration Assessment Program (CAP) | Russell Williams Insights West, Inc. 13293 Courtland Terrace San Diego, CA 92310 (619)259-0661 | \$495 |
| COGENOPT | Gary Ackerman Decision Focus Inc. 4984 El Camino Real Los Altos, CA 94022 (415)960-3450 | \$6,500 |
| Modular Stream System Analyzer (MESA) | The MESA Co. 22 Golden Shadow Circle The Woodlands, TX 77381 (713)363-3133 | \$15,000 |
| PG&E Financial Analysis Program | CDC Cybernet | Use Dependent |
| COGEN | M. Williams Software Systems Corp. 5766 Balcones Drive Austin, TX 78731 (512)451-8634 | \$495 |
| Cogenerator I | Don Roberts Energy Conversion Corp. 1310 Industrial Avenue Escondido, CA 92015 (619)746-8390 | \$495 |
| Cogeneration and Energy Planning Program (CEPP) | John M. Daniels ENCOTECH Inc. Box 174 Schenectady, NY 12301 (518)374-0924 | \$495 |

Table 2.2 Cogeneration Analysis Software (Cont.)

| Program Name | Point of Contact | Price |
|--|---|----------|
| Optimization and Simulation of Integrated Systems (OASIS) | Dorothy Bingamen Argonne National Lab. 9700 Cass Avenue Argonne, IL 60439 (312)972-3978 | Nominal |
| SYSTEMS & COGENERATION (SYSCOGEN) | Don Pedreyra Energy Systems Engineers 8000 E. Girard Ave. Suite 508 Denver, CO 82031 (303)696-6241 | \$895 |
| Dynalytic's Cogeneration Permitting Assessment (DYNCOPERM) | Herbert W. Cooper Dynalytics Corp. 260 No. Broadway Hicksville, NY 11801 (516)822-1760 | \$15,000 |
| Electric Load Following (ELF) | Hank Jackson RC&I Engineering Services, Inc. 3042 Courtney Drive Marietta, GA 30060 (404)435-4831 | Nominal |
| Cogeneration Trending (COGENT) | Philip Levine Fern Engineering, Inc. 1235 Route 28-A P.O. Box 655 Cataumet, MA 02534 (617)563-7181 | \$10,000 |

Small Cogeneration Analysis Program (SCAP)

The Small Cogeneration Analysis Program (SCAP) was developed by the Naval Civil Engineering Laboratory (NCEL) in 1987. The program will perform an economic analysis of potential PCS applications based on user-defined domestic hot water (DHW) curves or default DHW patterns for hospitals, barracks, and dining facilities. The program inputs for the default mode include the facility occupancy, fuel type (natural gas, propane, or diesel fuel), annual operating hours, water temperatures, and fuel costs. The user may specify a PCS design and input the associated capital and maintenance costs for that system, or use default design and cost values in the economic analysis. The user must also input discount and escalation

rates. The program outputs include the average hourly DHW load, energy usage and savings values, savings-to-investment ratio, and simple payback period.

Civil Engineering Cogeneration Analysis Program (CELCAP)

The original mainframe version of CELCAP was developed by the Naval Civil Engineering Laboratory in 1981 to analyze the performance of cogeneration systems. A microcomputer version of CELCAP was developed in 1987, and both versions are available for use.

CELCAP can analyze cogeneration systems comprised of gas turbines, diesel engines, extraction steam turbines, and back-pressure steam turbines. In the program, a waste heat boiler model is included in both the gas turbine and diesel engine models. CELCAP can analyze a system consisting of any combination of these four types, for a maximum of five engines. The input to the program consists of the design point and part-load performance of the engines, utility rate structure, fuel costs and escalation rates, operation and maintenance costs, and escalation rates for the engines. The electric and steam load is input as two 24-hour profiles for a typical working and non-working day for each month of the year. CELCAP calculates hourly values for the operating capacity of engines and boilers. Also, the electric and steam demand and supply for two days of each month are determined and listed as output. A monthly summary of the on-site electricity and steam generation is produced. Similarly, a monthly summary of the purchased electricity is displayed. CELCAP also lists the life-cycle fuel, operation and maintenance, and purchased power costs.

CELCAP runs on an IBM-XT/AT or compatible PC with a hard disk. A minimum of 400 kilobytes of RAM is required. A user-friendly data input program is provided with CELCAP to assist the user in preparing the data in the correct format.

Dual Energy Use System (DEUS)

DEUS was developed in 1981 to evaluate industrial cogeneration applications from a utility perspective. The program evaluates the potential benefits to a utility for site-specific industrial cogeneration applications.

Thermal and electrical loads are specified by the user for 36 time periods per year. For example, the 36 periods might consist of three time periods per day for three days per week for each of four seasons. Utility rates for each period must

be input by the user. Process heat for thermal loads may consist of a maximum of three streams of steam at different conditions. The program also allows for a waste energy utilization system to supplement process energy requirements. The cogeneration equipment can include steam turbines, coal-fired gassifiers, fuel cells, gas turbines, and diesel engines. The DEUS program sizes cogeneration equipment in one of two ways: either the thermal output of the cogeneration unit is matched to the thermal load or the user specifies the desired electrical output. The program allows for two sale/purchase agreements with the utility if the cogeneration system is owned by the industry.

The economic analysis can be performed for ownership by the industry, third party, or utility. Industrial and third-party ownerships are evaluated using discounted cash flow methods. For utility ownership, the revenue requirements necessary to achieve a specified return on investment are calculated.

DEUS required an IBM-XT/AT or compatible PC with a minimum RAM of 384 kilobytes, one fixed disk, and one 360-kilobyte floppy-disk drive.

Cogeneration Options Evaluation (COPE) Program

COPE is a cogeneration options evaluation program developed in 1983 to address the institutional and regulatory issues raised by cogeneration. The program evaluates different ownership structures and operating modes. Cost and performance information for the option being evaluated are specified, and the program performs an analysis of the impact on the utility, the industry, and a third party. For each option evaluated, the following information must be supplied by the user:

- a. Project timing
- b. Fuel use data
- c. Building and equipment costs
- d. Tax data
- e. Performance data
- f. Discount factors and escalation rates

Performance data for gas turbines, steam turbines, combined cycles, fuel cells, and diesel heat pumps are stored in the program. The outputs consist of cash flow data, cost savings, and payback parameters.

COPE runs on an IBM or compatible PC with a single 360-kilobyte disk drive and DOS 2.0 or later version.

Associated Cogeneration Analysis (ACE)

ACE was designed to assess the technical and economic feasibility of packaged cogeneration system installations in commercial and institutional buildings. It permits the user to consider the economic impact for various ownership options.

Electrical and thermal loads are specified by the user for four time periods for an average day in each month. The program will accommodate up to three thermal streams for devices such as boilers and chillers. Electricity prices can be selected from a preprogrammed utility structure or by inputting the average unit price with and without cogeneration. Cogeneration equipment types that can be evaluated by ACE include reciprocating engines, gas turbines, and steam turbines with or without an absorption chiller and thermal energy storage device. Thermal and electrical performance data are displayed by ACE on a monthly basis. The following five economic parameters are also calculated:

- a. Simple payback period
- b. Discounted payback period
- c. Internal rate of return
- d. Differential net present value
- e. Discounted savings percentage

The microcomputer system requirements to run the ACE program are IBM-PC compatibility and 256 kilobytes of RAM.

Cogeneration Feasibility Analysis Model (CFAM)

CFAM was developed for analyzing cogeneration energy systems for commercial and institutional applications. The program has the ability to perform a building energy analysis in addition to its primary function.

The CFAM program models building electrical, heating, and cooling loads using ASHRAE procedures and weather data. The user can select ten weather locations from a list of 60 possible locations. A typical weekday and weekend load profile for each month is used in the analysis. CFAM performs an analysis for the following four system configurations:

- a. Total electric (no utility interconnection)
- b. Total thermal
- c. Base electric
- d. Peak shaving

The cogeneration equipment consists of gas turbines or gas engines with heat recovery equipment and an absorption chiller if desired. The number of units and size of the equipment may be either specified by the user or designed by CFAM. The

program outputs include a monthly energy use summary, a cash-flow analysis, and estimates for the net present worth and internal rate of return for the four operational configurations.

CFAM system requirements are an IBM or compatible PC with 256 kilobytes or RAM, MS-DOS 2.10 operating system, and two disk drives.

Cogeneration Feasibility Analysis System (CFAS)

In the CFAS program, the weather data may be entered by the user or selected from a data file. Electricity and heating requirements can be entered directly into CFAS or from a Lotus 1-2-3 spread sheet. Utility rates are selected from a menu. Cogeneration equipment can include steam turbines, gas turbines, or reciprocating engines. CFAS calculates the system monthly thermal and electrical performance and performs an economic analysis for the first year of operation. An IBM or compatible PC is required to run the CFAS program.

COGENMASTER

COGENMASTER is a PC-based computer model developed in 1986 for EPRI to evaluate alternative cogeneration systems and options. The program analyzes the cogeneration option relative to a standard system in which electricity is purchased from the utility and thermal energy is generated on-site using a boiler. Options that may be analyzed include different technologies and operating strategies, as well as different ownership structures. COGENMASTER can evaluate alternative sizing criteria and operating modes for a facility. Also the effects of scheduled and unscheduled maintenance on the overall economics of the project can be assessed with the program.

Cogeneration Assessment Program (CAP)

The CAP software performs an hourly simulation of potential cogeneration candidates. The program is designed for use by utilities and includes a data base with process, space, and water heating energy use profiles for 25 different commercial and industrial facilities. User-specified profiles may also be used. Fuel and electric cost data and capital cost information are required to perform the analysis. The program also has an option for analyzing an application using an absorption chiller.

The program is designed to run on an IBM or compatible PC with MS/DOS and 256-K memory. The installation procedure requires approximately 1.5 hours, and the program takes 20 minutes to run.

COGENOPT

COGENOPT is an optimization model which evaluates industrial cogeneration systems based on net present value. Inputs to the program include load profiles, system sizes, equipment sizes, fuel and energy prices, and capital cost data. COGENOPT runs on an IBM or compatible PC with 256-K memory.

Modular Steam System Analyzer (MESA)

MESA models an existing or proposed steam system. Inputs to the program include:

- a. Steam temperatures, pressures, and flows
- b. Boiler, generator, and steam turbine characteristics
- c. Fuel and electric costs

The program is written in FORTRAN and requires an IBM or compatible PC with 384-K memory and a math coprocessor.

PG&E Financial Analysis Program

This program analyzes steam turbine-based cogeneration systems based on user-supplied data regarding the technical and cost characteristics. Outputs from the program include a 20-year cash flow, internal rate of return, net present value, and simple payback. Data input requirements include the seasonal peak, partial peak, and off-peak data, utility rates, fuel costs, equipment performance and costs, and financial assumptions. To run the program, a remote terminal capable of communicating with the CDC Cybernet Center is required.

COGEN

COGEN evaluates the thermodynamic and economic performance of a cogeneration system that uses backpressure steam turbine technology. The program is written in MBASIC and requires an IBM or compatible PC with 64-K memory.

Cogenerator I

Cogenerator I is an interactive tool for evaluating cogeneration feasibility. The data inputs include three years of previous electric billings and rates, fuel consumption and cost data, equipment choices, performance data, capital costs, and financial data. The program requires dBASE II and runs on any PC with MS/DOS, CP/M 80 or 86.

Cogeneration and Energy Planning Program (CEPP)

The CEPP software consists of five modules, including a

main program which simulates plant operations, a financial model, and three output programs. The user must input load profiles, equipment sizes and performance data, cost data, financing and tax information. The program will accept load performance data and will output system operating data including machine loading. To run the program, a Diablo, Xerox, or DEC terminal is required to communicate with the ENCOTECH computer. The program is also available in an IBM or compatible PC version.

Optimization and Simulation of Integrated Systems (OASIS)

OASIS was developed by Argonne National Laboratories to assist in the analysis and design of community energy systems. The program inputs include user-defined demands, operating strategies, weather data, equipment types, and performance data. A life-cycle cost analysis is performed based on the results of an hourly simulation.

SYSTEMS & COGENERATION (SYSCOGEN)

SYSCOGEN determines the actual energy consumption by various types of central plant equipment to meet the hourly requirements of a building or site. Hourly energy use is simulated by the program from actual monthly utility data or other program. The operating characteristics of the generator and auxiliary equipment are inputs to the system. The program prints a monthly summary of the gas, auxiliary fuel, and electricity consumed and generated. The peak electrical demand, operating hours, and evaluation of the thermal energy usage are also listed.

Dynalytic's Cogeneration Permitting Assessment (DYNCOPERM)

This program is an expert system that contains experience gathered while obtaining environmental permits. It can be used to evaluate the nature of the site and the types of drives and fuels being considered, as it lists the required permits and recommendations on control technologies. The program requires an IBM or compatible PC with MS/DOS and 640-K memory.

Electric Load Following (ELF)

This program is a SYMPHONY template that screens the economic potential for commercial or institutional cogeneration systems using the electric load-following approach. The effects of utility demand charges and declining block rate structures are included in the analysis. Outputs include the monthly comparison of before and after cogeneration cash flows and a life-cycle cost analysis. An IBM or compatible PC with 512-K

memory is required to run the program. Additionally, the program requires Lotus SYMPHONY to run, and in the present configuration some familiarity with the spreadsheet package is necessary to effectively use the template.

Cogeneration Trending (COGENT)

COGENT is applicable to the analysis of gas turbine cogeneration and combined cycle systems. It can be used to configure the gas turbine, boiler, and instrumentation to model the site. The outputs from the program include performance measures and diagnostics. This information can be used to schedule cleaning and maintenance to achieve maximum efficiency.

The program will run on a PC with an 80286 or 80386 processor and a math coprocessor. A hard disk with 512-K memory is required.

2.3.4 Regulatory Considerations

The four primary permit requirements for PCS installation include local building code permits, state permits, the Federal Regulatory Commission's (FERC's) Qualified Facility (QF) form, and environmental permits for pollution abatement.

Local area codes may require electrical utility, gas utility, and building department permits. State Implementation Plans (SIP) should be reviewed for PCS installation requirements. States may require environmental permits in addition to permits from the architects, engineering, or planning office. Both the local and state governments should be consulted to determine the requirements for PCS installation.

To attain a qualifying status with the Federal Energy Regulatory Commission, the QF application must be completed and a notice must be listed in the Federal Register. The QF application requires the following information:

- Name, Address, Location
- Facility and Cogeneration System Description
- Primary Energy Source
- Power Production Capacity
- Ownership
- Cogeneration System Efficiency Calculation
- Date of Installation

As discussed in Section 1.3, the Federal Energy Regulatory Commission in accordance with Section 201 of the Public Utility Regulatory Policies Act (PURPA) of 1978 requires an average, year-round efficiency of 42.5 percent. The efficiency must be calculated according to the relationship shown in Equation 1-1. To determine the fraction of time (F) that full heat recovery

would have to be in effect to attain FERC qualifying status, Equation 1-2 would be used.

The Environmental Protection Agency (EPA) office for the area in which the PCS is to be located should be contacted to determine the required pollution control equipment and regulatory steps for federal and state environmental approval. Air pollution resulting from the diesel or natural gas combustion is the primary source of pollution. The PCS combustion process may also produce water pollution and solid waste, but generally these wastes are insignificant. Acceptable emission levels are found in the 1980 Prevention of Significant Deterioration (PSD) regulations found in the Code of Federal Regulations (CFR) under Title 40, CFR 52.21. The EPA reviewing officials responsible for PSD regulations should be contacted to determine whether a PSD application will be required. Table 2.3 lists the emission levels considered significant under PSD regulations.

Table 2.3 Emission Levels Considered Significant Under PSD Regulations (Ref 4) (a)

| Pollutant | Emissions Rate (tons/year) |
|------------------------------|----------------------------|
| Carbon monoxide | 100 |
| Nitrogen oxides | 40 |
| Sulfur dioxide | 40 |
| Particulate matter | 25 |
| Ozone | 40 (b) |
| Lead | 0.6 |
| Asbestos | 0.007 |
| Beryllium | 0.0004 |
| Mercury | 0.1 |
| Vinyl chloride | 1 |
| Fluorides | 3 |
| Sulfuric acid mist | 7 |
| Hydrogen sulfide | 10 |
| Total reduced sulfur (c) | 10 |
| Reduced sulfur compounds (c) | 10 |

(a) In spite of the above values, any major source or modification located within 10 km of a Class I area that causes an increase of at least $1 \mu\text{g}/\text{m}^3$ in the ambient air condition (over the Class I area) for a regulated pollutant (i.e., a pollutant for which an emission or air quality standard has been established) is regarded as emitting significant amounts of that pollutant.

(b) Volatile organic compounds.

(c) Including hydrogen sulfide.

The primary air pollutants contributed by PCSs are particulates, sulfur dioxide (SO₂), and nitrogen oxides (NO_x). Carbon monoxide (CO) and hydrocarbons (HC) are of secondary concern.

Federal water pollution standards apply to facilities that generate electricity for distribution and sale. Facilities with a capacity rated less than 25 MW are exempt from these standards unless they are part of an electric utility system with a total net capacity greater than 150 MW (Ref 4).

In most cases, the amounts of water pollutants and solid waste generated from natural gas or diesel-fired engines are insignificant, provided that a low-sulfur fuel is burned. PCS facilities can generally dispose of any water used for cooling into the municipal sewer. For these facilities, a municipal sewer permit is required. However, some states require that noncontaminated cooling water be discharged into the storm sewer. The discharge of wastewater into a storm sewer requires that a National Pollution Discharge Elimination System (NPDES) permit be obtained.

Any facility which requires an oil storage tank capacity in excess of 1,320 gallons above ground or 40,000 gallons below ground will require a Spill Prevention, Control and Countermeasure (SPCC) Plan.

A list of potential environmental permit requirements is shown in Table 2.4 (Ref 5). In most instances, packaged cogeneration systems will require only air and water pollution permits. However, if the PCS is constructed in a wetlands or has an exceptionally tall stack, additional permits may be required. To determine which permits are applicable, the following data should be collected and analyzed:

- Facility description and location (plot plans, drawings, technical information, etc.)
- PCS description and method of operation
- Fuel type, quantity, usage and combustion efficiency
- Pollution emission levels
- Water requirements and effluent discharges
- Stack height, diameter, and velocity

Table 2.4 Potential Environmental Approvals
for Packaged Cogeneration Systems

| Description | Agency |
|---|-------------------|
| AIR POLLUTION | |
| Prevention of Significant Deterioration | EPA/State |
| Nonattainment Review | EPA/State |
| Permits to Construct/Operate | EPA/State |
| WATER POLLUTION | |
| Process & Stormwater Discharge | EPA/State |
| National Pollutant Discharge Elimination System (NPDES) | EPA/State |
| Sewer Use | State/Local |
| 401 Water Quality Certificate | EPA/State |
| Water Diversion | State |
| SPCC | EPA/State |
| SITE-RELATED | |
| Wetlands | Corps/Local/State |
| Stream Encroachment | State |
| Soil Erosion/Earth Disturbances | State |
| Flood Plain | State |
| Coastal Zone Management | State |
| Drainage | State/Local |
| MULTIMEDIA | |
| Environmental Assessment (EA) | Federal/State |
| Environmental Impact Statement (EIS) | Federal/State |
| Facility Siting Evaluations | State |
| OTHER | |
| FAA Obstruction Evaluation | Federal |
| Dredge & Fill | Corps/State |
| Bridge Permit | Coast Guard |
| Cooling Tower Impacts | State |
| Solid Waste Processing/Disposal | State |

2.4 Financing Options

The three broad categories for PCS financing are as follows:

- Navy-owned and operated
- Third-party (including Shared Savings) development and operation
- Navy owned/third-party built and operated

For a Navy-owned and operated PCS, the Navy has responsibility for all costs associated with design, construction, maintenance, and operation of the PCS. One benefit from owning the system is that the Navy receives all of the energy and cost savings. This may be the least expensive financing method because benefits are not shared with another party. This financing structure is the most simple; it is a traditional, well-established method of operating. However, the Navy assumes all of the risk associated with the expected energy and cost savings. Similarly, the Navy must raise all of the capital necessary to fund the project.

In the case of a third-party developed and operated PCS, the cogeneration developer assumes all responsibility for the cogeneration project, including design, construction, operation, and maintenance. The developer may guarantee the Navy a savings (e.g., savings of at least 15 percent on annual energy bills). In return the developer receives a share of the project savings. The advantages to this type of financing are that the risks to the Navy are minimized, energy savings may be guaranteed, and no capital expenditures are required. However, the maximum possible savings the Navy can realize will not be as great as with a Navy-owned system. The contractual arrangement is generally more complicated and is in effect for relatively long periods of time (typically 5 to 15 years). At the end of the contractual arrangement, the Navy will purchase the PCS at a fair market value.

For a Navy-owned/third-party-built and operated financing arrangement, the PCS developer will design, construct, and assist in the operation and maintenance of the system. The Navy will own the unit and help with the operation and maintenance. This form of financing allows the Navy to obtain many of the advantages of a Navy-owned and operated system without much of the associated risk. However, in exchange for the developer's taking a significant amount of the risk, the maximum potential savings realized by the Navy will be reduced.

Previous studies of cogeneration systems with maintenance contracts showed an increased average availability of 19.3 percent over those without (Ref 6). Systems with maintenance contracts were maintained at a lower cost and achieved higher efficiencies. The average maintenance cost for systems with contracts was \$0.0153/kWh, compared with \$0.0312/kWh for systems that were owner-maintained. The average electric efficiency for

third-party-maintained systems was 25.8 percent as opposed to 24.5 percent for owner-maintained systems. Because the third-party maintenance contracts have shown to be both efficient and cost-effective, a financing arrangement in which the maintenance is performed by the PCS developer is recommended.

III. Design

3.1 Recommended Modifications to NAVFAC Design Criteria

It is recommended that the following PCS information be added to NAVFAC DM-3 (Design Manual; Mechanical Engineering) in Chapter 9 (Power Plants), Section 3 (Internal Combustion Engine Power Plants), part 2 (Nonstandard Plants):

. COGENERATION; PACKAGED COGENERATION SYSTEMS (PCS)

a. Description. Packaged Cogeneration Systems consist of systems with electric generating capacities below 500 kW which use prime movers such as reciprocating engines or gas turbines. Heat recovery equipment is added to the system to generate steam or hot water for domestic hot water, space heating, absorption cooling, and industrial process heat. See Figures 9-13A and 9-13B.

b. Applications. PCS applications include BOQ/BEQs, dining facilities, laundries, multifamily housing, computer facilities, industrial facilities, and hospitals where the following conditions are met: (1) a thermal load of at least 100,000 Btu/hr (equivalent electrical output of a 20 kW cogeneration unit) for a minimum of 6,000 hours per year and (2) a relatively high electrical-to-fuel cost differential of \$15/MBtu or higher.

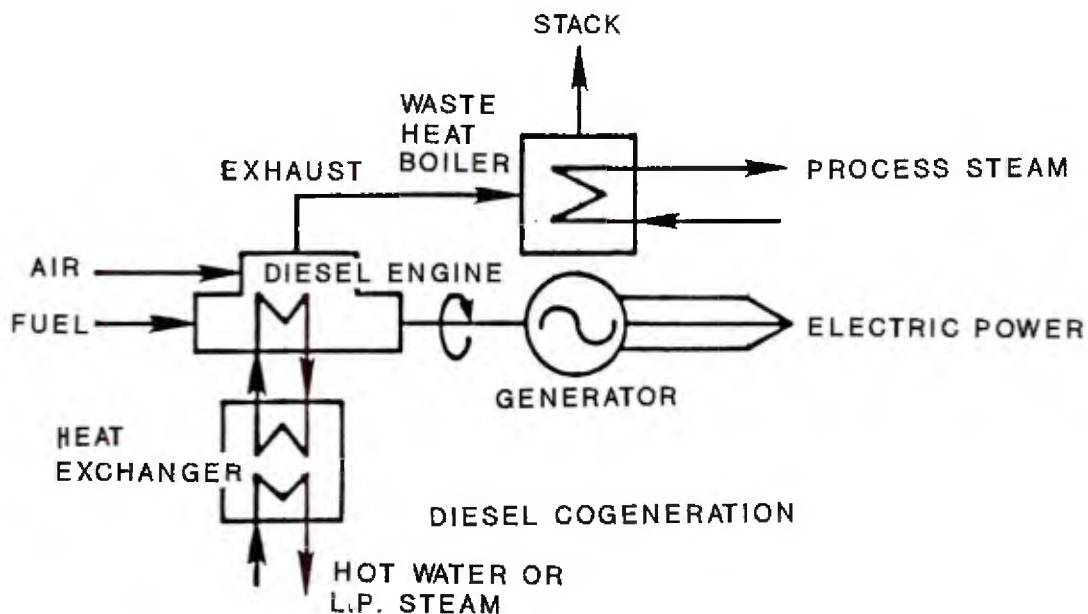

Figure 9-13A. Reciprocating-Engine PCS

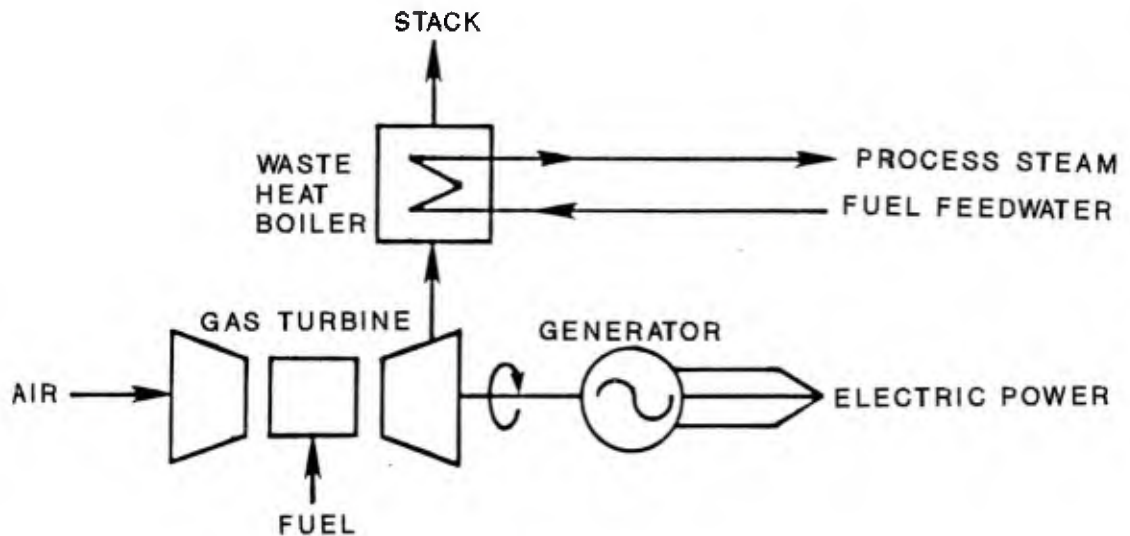

Figure 9-13B. Gas-Turbine PCS with Heat Recovery

3.2 Design Considerations

The design procedure for a PCS is generally much simpler than that for site-specific cogeneration systems because of the packaged nature of the PCS. There are many PCS manufacturers who offer packaged units of standard sizes; therefore, designing essentially consists of selecting a correctly sized unit.

In addition to sizing the system, several design and technical variables should be considered during the design process. Some of the design variables are as follows:

- Single-unit system or multiple-unit system
- Industrial or automotive-type engine
- Induction or synchronous generator
- Standard or optional radiator
- Microprocessor or relay controls
- Factory assembled and tested or site assembled
- Location of the unit at the site and the proximity of electrical and thermal equipment to the unit
- Electrical or absorption chiller or both
- Hot water or low-pressure steam
- Type and availability of fuel

Some of the operational variables that should be considered during the design phase are as follows:

- Continuous or intermittent operation
- Manual or automatic operation
- Thermal load following or operation at peak electrical capacity

The industrial engines used in PCSs are essentially diesel engines converted to run on natural gas. They operate 24,000 to 36,000 hours between major overhauls. The automotive engines used in PCSs are modified with special valves and heads to prolong life. They operate 8,000 to 12,000 hours between major overhauls.

The synchronous generators are self-exciting, compatible with the utility grid, and produce power in case of outages. However, they are more expensive than induction generators. The induction generators rely on utility line frequency and cannot operate without utility power. They are less expensive and are used in most PCS applications.

IV. Specifications

4.1 Camp Pendleton Procurement Specifications

A few selected pages of the procurement specification for the installation of two packaged cogeneration units at the Marine Corps Base, Camp Pendleton, CA are included in Appendix D for reference. Although the energy and maintenance requirements detailed in this document are specific to the Camp Pendleton applications, this document can be used as a reference for development of other procurement specifications for PCS installations.

V. Construction/Procurement

5.1 List of Potential PCS Vendors

A variety of pre-engineered, prepackaged small cogeneration systems are commercially available. These systems include but are not limited to the PCS manufacturers listed in Table 5.1. This list changes frequently due to the rapidly expanding small cogeneration market. Electrical and thermal outputs, engine properties, fuel requirements, and maintenance information for each PCS are shown in Table 5.1. Points of contact and addresses for each supplier are also included for reference.

Table 5.1 Packaged Cogeneration System (PCS) Suppliers and Related Information

| Manufacturer | ELECTRICAL | | ENGINE | | FUEL | | | THERMAL | | | MAINTENANCE | | | | |
|--|------------|-------|-----------|------|------|-----|----------|---------|------|--------|----------------|--------------------|------|----------------|-----------------|
| | kW | Volts | Gen. Type | Type | hp | RPM | Noise Db | Nat Gas | Prop | Diesel | Wat Output GPM | Steam Output KBtuH | PSIG | Basic Serv Hrs | Minor Ovrhl Hrs |
| Fermont 141 North Ave. Bridgeport, CT 06606 | 330 | | IC | | | | | | | | 3243 | 1347 | | | |
| Contact: (203)366-5211 | | | | | | | | | | | | | | | |
| MAN GHM Corp. 50 Broadway New York, NY 10004 | 100 | | IC | | | | | 1125 | | | | 650 | | | |
| Contact: | 125 | | IC | | | | | | | | 1165 | 575 | | | |
| | 200 | | IC | | | | | 2045 | | | | 1145 | | | |
| | 225 | | IC | | | | | | | | 2170 | 1050 | | | |
| Contact: | 300 | | IC | | | | | 3450 | | | | 2030 | | | |
| (212)363-2637 | 375 | | IC | | | | | | | | 3100 | 1250 | | | |
| Teledyne Total Power 3409 Democrat Rd. Memphis, TN 38118 | 22 | | IC | | | | | 320 | | | | 187 | | | |
| Contact: (901)365-3600 | | | | | | | | | | | | | | | |

Table 5.1 Packaged Cogeneration System (PCS) Suppliers and Related Information (Cont)

| Manufacturer | ELECTRICAL | | ENGINE | | | | | FUEL | | | THERMAL | | MAINTENANCE | | | |
|---|------------|-------|-----------|------|-----|------|----------|-----------------|--------------|---------------|----------------|----------------------|-------------|----------|------------------|------------------|
| | kW | Volts | Gen. Type | Type | lip | RPM | Noise Db | Nat Gas KBtu/HR | Prop KBtu/HR | Diesl KBtu/HR | Wat Output GPM | Steam Output KBtu/HR | PSIG | Serv Hrs | Basic Ovrhrl Hrs | Minor Ovrhrl Hrs |
| TECOGEN Inc. 45 First Ave. Waltham, MA 02254 | 25 | 1 | I | IC | 33 | 1800 | 70 | 320 | | | | 190 | | 750 | n/a | n/a |
| Contact: Robert Sliwoski (805)527-4107 | 60 | 1 | I | IC | 40 | 1800 | 70 | 390 | | | | 219 | | 750 | n/a | n/a |
| | 75 | 1 | I | IC | 80 | 1800 | 70 | 776 | | | | 440 | | 750 | n/a | n/a |
| | 200 | 1 | I | IC | 100 | 1800 | 70 | 910 | | | | 490 | | 750 | n/a | n/a |
| | 500 | 1 | I | IC | 268 | 1200 | 70 | 2430 | | | | 1182 | | 750 | n/a | n/a |
| | | | | | 670 | 1200 | 70 | 7850 | | | | | 125 | 750 | n/a | n/a |
| Hawthorne Engine Systems 8050 Othelo Ave San Diego, CA 92112 | 60 | | E | IC | | | | SAC | | | | 427 | | | | |
| Contact: George W. Martin (619)279-4330 | 80 | | E | IC | | | | SAC | | | | 630 | | | | |
| | 54 | | E | IC | | | | SAC | | | | 373 | | | | |
| | 68 | | E | IC | | | | SAC | | | | 419 | | | | |
| | 90 | | E | IC | | | | SAC | | | | 568 | | | | |
| | 90 | | E | IC | | | | SAC | | | | 547 | | | | |
| | 113 | | E | IC | | | | SAC | | | | 605 | | | | |
| Babcock and Wilcox Cogen Pak 20 S. Van Buren Ave Barberton, OH 44203 | 65 | | | IC | | | | 800 | | 800 | | 470 | | | | |
| Contact: David Keller (216)860-2060 | 110 | | | IC | | | | 1200 | | 1200 | | 705 | | | | |
| | 148 | | | IC | | | | 1500 | | 1500 | | 880 | | | | |
| | 208 | | | IC | | | | 2200 | | 2200 | | 1300 | | | | |
| Double Energy Systems 1120 Industrial Ave Escondido, CA 92025 | 6 | | | IC | | | 62 | 85 | | | | 74 | | | | |
| Contact: Chuck Sorter (619)489-9212 | 6 | | | IC | | | 71 | | | 81 | | 72 | | | | |
| | 7.5 | | | IC | | | 62 | 88 | | | | 79 | | | | |
| | 7.5 | | | IC | | | 71 | | | 93 | | 71 | | | | |
| | 10 | | | IC | | | 68 | 160 | | | | 121 | | | | |
| | 10 | | | IC | | | 79 | | | | | 90 | | | | |
| | 15 | | | IC | | | 68 | 172 | | 139 | | 121 | | | | |
| | 15 | | | IC | | | 80 | | | 163 | | 101 | | | | |
| | 20 | | | IC | | | 68 | 216 | | | | 136 | | | | |
| | 20 | | | IC | | | 80 | | | 234 | | 146 | | | | |
| | 30 | | | IC | | | 68 | 327 | | | | 196 | | | | |
| | 30 | | | IC | | | 80 | | | 447 | | 207 | | | | |
| Intellicon Inc. 7750 Daggett St. Suite 201 San Diego, CA 92111 | 65 | | | IC | | | 778 | | | | | 366 | | | | |
| Contact: Jim Ring (619)569-7141 | 100 | | | IC | | | 1137 | | | | | 595 | | | | |
| | 230 | | | IC | | | 2516 | | | | | 1297 | | | | |

Table 5.1 Packaged Cogeneration System (PCS) Suppliers and Related Information (Cont)

| Manufacturer | ELECTRICAL | | ENGINE | | | | FUEL | | | THERMAL | | MAINTENANCE | | | | |
|---|------------|-------|-----------|------|----|------|----------|----------------|-------------|--------------|----------------|---------------------|------|----------------|-----------------|-----------------|
| | kW | Volts | Gen. Type | Type | hp | RPM | Noise Db | Nat Gas KBTU/H | Prop KBTU/H | Diesl KBTU/H | Wat Output GPM | Steam Output KBTU/H | PSIG | Basic Serv Hrs | Minor Ovrhl Hrs | Major Ovrhl Hrs |
| Cogeneration Engineering | 20 | | S | IC | | | | 250 | | 250 | 150 | | 1700 | N/A | 32000 | |
| 660 W Baltimore Ave. Media, PA. 19063 | 55 | | S | IC | | | | 594 | | 594 | 356 | | 1700 | N/A | 32000 | |
| | 75 | | S | IC | | | | 810 | | 810 | 486 | | 1700 | N/A | 32000 | |
| | 100 | | S | IC | | | | 1080 | | 1080 | 648 | | 1700 | N/A | 32000 | |
| | 200 | | S | IC | | | | 2160 | | 2160 | 1296 | | 1700 | N/A | 32000 | |
| Contact: | | | | | | | | | | | | | | | | |
| Ernest Abell | | | | | | | | | | | | | | | | |
| (215)566-0564 | | | | | | | | | | | | | | | | |
| TELEDYNE Total Power | 22 | 2 | I | IC | 61 | 1200 | 72 | 307 | | 307 | 187 | | | | | |
| 3409 Democrat Rd. | | | | | | | | | | | | | | | | |
| P.O. Box 181160 | | | | | | | | | | | | | | | | |
| Memphis, TN 38181 | | | | | | | | | | | | | | | | |
| Contact: | | | | | | | | | | | | | | | | |
| Ron Gregory | | | | | | | | | | | | | | | | |
| (901)369-4007 | | | | | | | | | | | | | | | | |
| Martin Cogeneration | 65 | 1 | | IC | | | | 887 | | | 412 | | 750 | 10000 | 20000 | |
| 1637 S.W. 42nd St. P.O. Box 1698 Topeka, Kansas 66601 | 100 | 1 | | IC | | | | 1291 | | | 620 | | 750 | 10000 | 20000 | |
| | 150 | 1 | | IC | | | | 1838 | | | 833 | | 750 | 10000 | 20000 | |
| Contact: | | | | | | | | | | | | | | | | |
| Mike Gudenkauf | | | | | | | | | | | | | | | | |
| (913)266-5784 | | | | | | | | | | | | | | | | |
| Micro Cogen Systems | 20 | 1 | I | IC | | 1800 | 70 | 280 | | | 170 | | | | | |
| 16795 Von Karman | | | | | | | | | | | | | | | | |
| Irvine, CA 92714 | | | | | | | | | | | | | | | | |
| Contact: | | | | | | | | | | | | | | | | |
| Mr. Lynch | | | | | | | | | | | | | | | | |
| (714)863-7000 | | | | | | | | | | | | | | | | |
| Cogenic Energy Systems | 65 | 1 | E | IC | | 1800 | SAC | 800 | | | 450 | | 500 | n/a | 30000 | |
| 9929 Hibert Street Suite A San Diego, CA 92131 | 100 | 1 | E | IC | | 1800 | SAC | 1200 | | | 630 | | 500 | n/a | 30000 | |
| | 120 | 1 | E | IC | | 1800 | SAC | | | 1330 | 680 | | 500 | n/a | 30000 | |
| | 150 | 1 | E | IC | | 1800 | SAC | 1783 | | | 831 | | 500 | n/a | 30000 | |
| | 185 | 1 | E | IC | | 1800 | SAC | | | 1676 | 925 | | 500 | n/a | 30000 | |
| | 200 | 1 | E | IC | | 1800 | SAC | 2377 | | | 1148 | | 500 | n/a | 30000 | |
| | 290 | 1 | E | IC | | 1800 | SAC | 3566 | | | 1710 | | 500 | n/a | 30000 | |
| Contact: Richard Davidson (619)695-3760 | 325 | 1 | E | IC | | 1200 | SAC | 3831 | | | 1672 | 15 | 500 | n/a | 30000 | |
| | 350 | 1 | E | IC | | 1200 | SAC | 4079 | | | 2110 | 15 | 500 | n/a | 30000 | |
| | 450 | 1 | E | IC | | 1200 | SAC | 5600 | | | 2482 | 15 | 500 | n/a | 30000 | |

Table 5.1 Packaged Cogeneration System (PCS) Suppliers and Related Information (Cont)

| Manufacturer | ELECTRICAL | | ENGINE | | | | FUEL | | | THERMAL | | | MAINTENANCE | | | |
|---|------------|-------|-----------|------|------|-----|----------|---------------|------------|--------------|----------------|--------------------|-------------|----------------|-----------------|-----------------|
| | kW | Volts | Gen. Type | Type | hp | RPM | Noise Db | Nat Gas KBTuH | Prop KBTuH | Diesel KBTuH | Wat Output GPM | Steam Output KBTuH | PSIG | Basic Serv Hrs | Minor Ovrhl Hrs | Major Ovrhl Hrs |
| KW Energy Systems P.O. Box 566 South Deerfield, MA 01373 | 75 | | E | SI | 3650 | | SAC | | | | | | 125 | 2200 | 8700 | 26000 |
| | 500 | | E | SI | 3650 | | SAC | | | | | | 125 | 2200 | 8700 | 26000 |
| Contact: Lynn DiTullio (413)665-7081 | | | | | | | | | | | | | | | | |
| Onan Corporation 1400 73rd Ave. NE Minneapolis, MN 55432 | 50 | | | IC | | | | | | 585 | | 161 | | | | |
| | 100 | | | IC | | | | | | 1215 | | 238 | | | | |
| | 200 | | | IC | | | | | | 2219 | | 409 | | | | |
| | 500 | | | IC | | | | | | 5698 | | 1505 | | | | |
| Contact: Jerry Bristol (612)574-8143 | | | | | | | | | | | | | | | | |
| ICC Technologies 441 N. Fifth St. Philadelphia, PA 19123 | 75 | | | IC | | | | 926 | | | | 467 | | | | |
| | 150 | | | IC | | | | 1852 | | | | 540 | | | | |
| Contact: (215)592-8299 | | | | | | | | | | | | | | | | |
| Alturdyne 8050 Armour San Diego, CA 92111 | 450 | | | IC | | | | 5879 | | | | 2700 | | | | |
| Contact: (619)565-2131 | | | | | | | | | | | | | | | | |
| ASK Corporation PO Box 2512 700 W. Loop 340 Waco, TX 76702 | 35 | | | IC | | | | 465 | | | | 240 | | | | |
| | 60 | | | IC | | | | 769 | | | | 450 | | | | |
| Contact: (817)776-3860 | | | | | | | | | | | | | | | | |
| Symtec Inc. 220 Metro Center Blvd. Warwick, RI 02888 | 50 | | | IC | | | | 619 | | | | 300 | | | | |
| | 55 | | | IC | | | | 676 | | | | 324 | | | | |
| | 75 | | | IC | | | | 940 | | | | 461 | | | | |
| | 102 | | | IC | | | | 1289 | | | | 607 | | | | |
| | 185 | | | IC | | | | 2289 | | | | 1079 | | | | |
| Contact: (401)738-1670 | 335 | | | IC | | | | 4339 | | | | 2196 | | | | |
| | 450 | | | IC | | | | 5490 | | | | 2710 | | | | |

Table 5.1 Packaged Cogeneration System (PCS) Suppliers and Related Information (Cont)

| Manufacturer | ELECTRICAL | | ENGINE | | | | FUEL | | | | THERMAL | | | MAINTENANCE | | |
|-------------------|------------|-------|--------|------|------|------|----------|-----------|------------|-------------|------------|------------|----------|-------------|-----------------|--|
| | kW | Volts | Gen. | | lip | RPM | Noise Db | Nat | | | Wat Output | Steam PSIG | Serv Hrs | Ovrhl Hrs | Major Ovrhl Hrs | |
| | | | Type | Type | | | | Gas KBTuH | Prop KBTuH | Diesl KBTuH | | | | | | |
| WESI/PAMCO | 100 | | IC | | 1800 | | 1200 | | | | 630 | | | | | |
| 17803 S. Santa Fe | 120 | | IC | | 1800 | | 1330 | | | | 680 | | | | | |
| Rancho Dominguez, | 145 | | IC | | 1800 | | 1670 | | | | 830 | | | | | |
| CA 90221 | 145 | | IC | | 1800 | | 1670 | | | | 810 | | | | | |
| | 350 | | IC | | 1200 | | 4000 | | | | 2000 | | | | | |
| Contact: | 500 | | IC | | 1200 | | 6000 | | | | 3000 | | | | | |
| Wm. J. Hughes | 500 | | IC | | 1200 | | | | | 5500 | 2700 | | | | | |
| (414)547-3311 | 500 | | IC | | 1200 | | | | | 5500 | 2500 | | | | | |
| ENERCO, Inc. | 6 | 3 | E | IC | 8 | 1200 | 80 | | | | | | | | | |
| P.O. Box 7811 | 10 | 3 | E | IC | 14 | 1200 | 80 | | | | | | | | | |
| Murry, Utah 84107 | 12 | 3 | E | IC | 17 | 1200 | 80 | | | | | | | | | |
| | 21 | 2 | E | IC | 29 | 1200 | 80 | | | | | | | | | |
| Contact: | 25 | 2 | E | IC | 34 | 1800 | 80 | | | | | | | | | |
| Carl Clark | 34 | 2 | E | IC | 47 | 1800 | 80 | | | | | | | | | |
| (801)566-7744 | 50 | 2 | E | IC | 70 | 1800 | 80 | | | | | | | | | |
| | 75 | 2 | E | IC | 104 | 1800 | 80 | | | | | | | | | |
| | 125 | 2 | E | IC | 173 | 1800 | | | | | | | | | | |
| | 250 | 2 | E | IC | 345 | 1200 | | | | | | | | | | |

Voltage:
 1 = 240/480, 60 hz, 3 phase 2 = 120/240, 60 hz, 3 phase 3 = 120/240, 60 hz, single phase

Generator Type:
 I = Induction S = Synchronous E = Either

Noise Db:
 SAC = Sound Attenuation Cabinet

5.2 Cost Considerations

The Gas Research Institute (GRI) recently completed a study of 53 natural-gas-fired PCS sites (Ref 8). The results of this study showed the average manufacturing and installation cost of a gas-fired unit was \$1,344/kW with a range of \$600 to \$2,800/kW. Figure 5.1 shows the relationship between the total installed costs (\$/kW) and electrical output (kW).

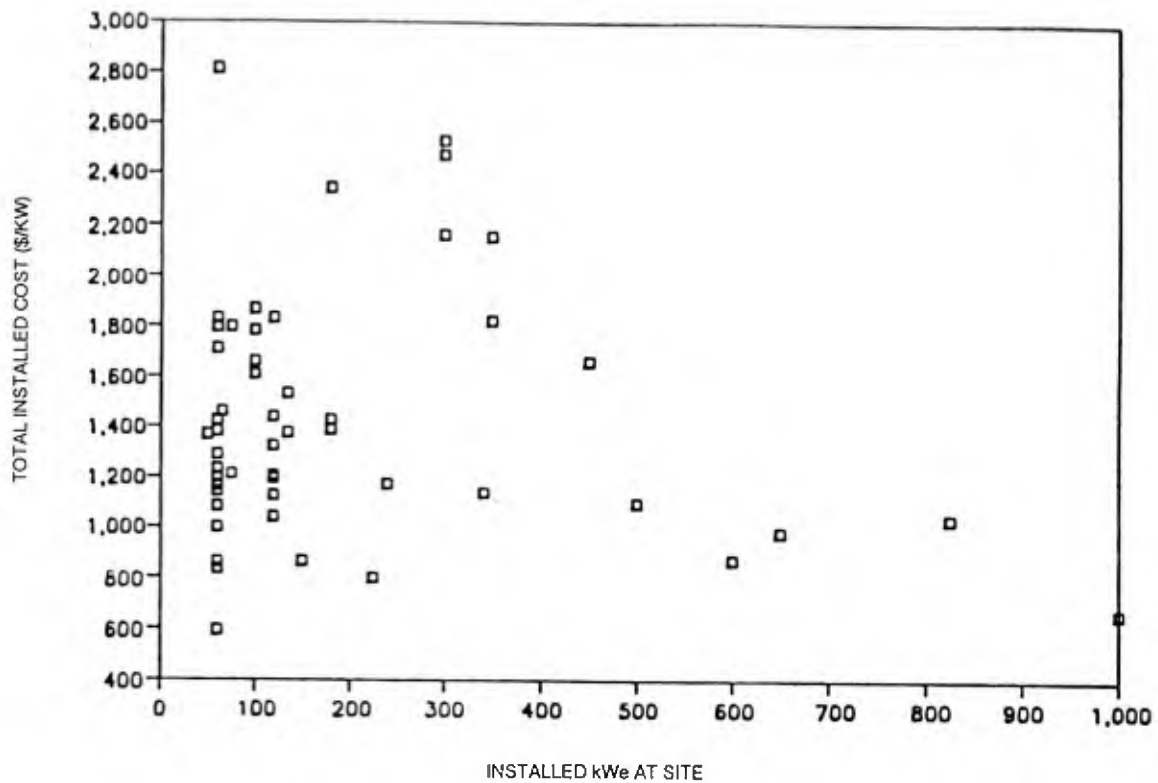

Figure 5.1 Correlation of Total Installed Costs (\$/kW) with Site Installed kW (Ref 8)

Two cost figures for diesel-fired PCSs were available. The Cogenic Energy Systems 120 kW model (M-120DWS) was priced at approximately \$100,000, or \$830/kW for purchase, delivery, and installation (Ref 9). Similarly, the purchase price of the Onan Corporation 200 kW unit (model number 200 DFY) was \$135,000 or \$675/kW. The installation cost for the Onan unit was 50 percent of the purchase price, for a total cost of \$1,010/kW for purchase, delivery, and installation (Ref 9).

Although no cost data were available for gas turbine PCSs, a value of \$800/kW may be used as a rough guideline for estimating the costs of purchase, delivery, and installation.

In addition to the costs mentioned above, the integration labor requirements for a 100 kW PCS installation are shown in Table 5.2.

Table 5.2 Integration (Soft) Cost Labor (Ref 10)

| Integration Cost Category | Man-Days of Effort |
|-----------------------------------|-----------------------|
| Feasibility Study | 1 |
| Utility Interface Negotiations | 4 |
| Permitting | 4 |
| Legal/Financial/Technical Support | 1 |
| Design Engineering | 2 |
| Bid and Award Cycle | 1 |
| Construction Oversight | 3 |
| Startup | 2 |
| Other | 4 |
| Total | 22 |

VI. Maintenance and Operation

6.1 Overview

The purpose of this chapter is to provide integrated logistics support (ILS) information and reliability, availability, and maintainability (RAM) data for packaged cogeneration systems (PCSs). The information provided can assist maintenance personnel to develop optimal service schedules for PCSs based on extensive commercial experience. The supply support, test and evaluation equipment, training, technical data, and packaging, handling, storage and transportation information details are provided to assist in the implementation procedure. The RAM information for PCS units is provided to ensure that PCS operators will obtain the maximum benefit from the unit with the lowest operating cost and minimum disruption in operation.

6.2 Integrated Logistics Support for the PCS

6.2.1 Maintenance

As discussed in Chapter 2 (Planning), PCSs with a maintenance contract were maintained at a lower cost and achieved higher efficiencies. These systems also benefited from an increased average availability (Ref 6). Because the third-party maintenance contracts have shown to be both efficient and cost-effective, a maintenance agreement with the PCS vendor is recommended.

In case the PCS is to be Navy operated and maintained, Table 5.1 lists the recommended operational hours between a basic service, minor overhaul, and major overhaul for specific systems. In general, the following schedule (Ref 6 and 7) is recommended:

Basic service (Daily-500 service hours)

- Sample crankcase oil
- Measure oil level
- Change oil and oil filter
- Clean air filter
- Visually inspect belts, hoses, plugs, and plug wires for wear
- Check battery and coolant levels
- Check for oil and coolant leaks
- Clean crankcase breather assembly

Minor overhaul (1000-2000 service hours)

- Check ignition timing
- Perform timed consumption test (to check electrical efficiency)
- Inspect exhaust system and under-hood wiring harness for signs of heat stress
- Check and record vibration (IRD analysis)
- Check and adjust valves
- Check valve rotators
- Check exhaust emissions
- Replace rotor and brushes
- Service magneto
- Lubricate tachometer angle drive fitting

Major overhaul (Annually)

- Grease generator bearings
- Perform compression tests
- Inspect and lubricate generator and feeder circuit breakers
- Check and calibrate metering system
- Check for and repair any engine exhaust leaks
- Inspect generator cooling passages for blockage
- Inspect all rubber hoses and fittings for cracks
- Inspect entire module for damage and corrosion
- Check setting of radiator fan thermostats

The maintenance schedules for the heat recovery and other auxiliary equipment should be included in the service manual for the equipment.

6.2.2 Manpower

The PCS can be operated with the same personnel that operate the basic power plant. Additional personnel are not required.

A majority of the regular maintenance tasks do not require significant manpower. The daily inspection takes about an hour, and monthly service takes about 4 hours. Some of the typical service periods and maintenance tasks, along with an estimate of the number hours needed, are shown in Table 6.1.

Table 6.1 Estimated Hours Needed for PCS Service

| Service Period | Maintenance Task | Estimated Hours needed |
|------------------|---|------------------------|
| Daily | 1. Visual inspection | 1/2 |
| | 2. Check oil level, oil pressure, coolant temperature | 1/4 |
| | 3. Check battery charge rate | 1/4 |
| Every 500 hours | 1. Check air filters; change as required | 1/2 |
| | 2. Check electrolyte level of batteries; adjust as required | 1/4 |
| | 3. Collect lube oil sample for analysis | 1/4 |
| | 4. Conduct an analysis of lube oil | 1/2 |
| | 5. Change oil and filters | 1 |
| Every 1000 hours | 1. Clean and gap spark plugs; replace as required | 2 |
| | 2. Check operation of shutoff switches | 1/2 |
| | 3. Check and record vibration | 1/2 |
| | 4. Check generator commutator sliprings; clean as required | 1 |
| Every 2000 hours | 1. Check and adjust valves | 2 |
| | 2. Check valve rotators | 1/2 |
| | 3. Check and adjust ignition timing | 1/2 |
| | 4. Check exhaust emissions | 1/2 |

6.2.3 Supply Support

It is recommended that all recommended maintenance be covered in the service agreement with the vendor; thus, all spare parts will be vendor supplied.

If the unit is to be Navy maintained, a Recommended Spare Parts List (RSPL) for parts that are to be replaced on a yearly or more frequent basis should be obtained from the PCS supplier and submitted to NAVFAC for review and approval. The approved spare parts list will be forwarded to the designated lead NAVFAC Engineering Field Division (EFD) for procurement action. When the procurement action is initiated, the approved spare parts list will be used as the provisioning technical documentation (PTD), which will be furnished to the contractor in accordance with MIL-STD-1552 and MIL-STD-1561.

Following receipt of the PTD and related technical manuals, the Ships Control Center (SPCC) will develop data files to

support the inventory management process, including stock control and allowance determination.

At the time of procurement of the PCS, actions to procure the necessary support equipment will be initiated. The support list will be provided to the appropriate EFD. A list of required special-purpose tools and test equipment will be made available from the appropriate EFD and used as line items in the applicable production contracts. To avoid unnecessary procurement, activity personnel will compare the listing with existing assets and request only the general-purpose tools and test equipment needed to support the PCS maintenance and operation.

6.2.4 Test and Evaluation Equipment

As a minimum, the following test and evaluation equipment should be provided:

- Fuel meter (for natural gas, diesel, or propane)
- Btu meter or hot-water meter
- Industrial thermometer
- Watt-hour meter
- Microprocessor controls for all engine functions (optional)

6.2.5 Training

It is recommended that the PCS be operated and maintained by the supplier. No specialized training of Navy personnel will be required in this case. However, for a Navy-operated and maintained PCS, the following training is recommended:

- A system training and orientation course conducted by the PCS equipment supplier
- Training courses for PCS operators conducted by the Naval Civil Engineering Laboratory (NCEL) and the Naval Energy and Environmental Support Activity (NEESA)

A program will be developed by NCEL/NEESA to train personnel to operate and maintain PCS equipment after a decision is made to procure the system. This program will consist of an on-site NEESA operation and maintenance course.

NEESA instructors will receive the factory-level training from the PCS equipment supplier. The operator training course will be divided into lessons for each subsystem of the PCS. The course consists of prepared lesson plans, lesson outlines, lectures, and quiz material for each subsystem.

6.2.6 Technical Data

The technical logistics data include engineering drawings from the PCS installation at the U.S. Naval Station Treasure Island and technical manuals for the Tecogen PCS units at Treasure Island and Camp Pendleton. The drawings are listed in Table 6.2.

Table 6.2 U.S. Naval Station Treasure Island Drawings

| Title | Drawing Number | Sheet |
|--------------------------------------|----------------|-------|
| Plan and Section Views | 14-27 | 1/3 |
| Mechanical and Electrical Schematics | 14-27 | 2/3 |
| Maps and Details | 14-27 | 3/3 |

The only known technical manuals for PCS are:

- Tecogen Incorporated, Equipment Parameters and System Design Data, CM-200, CM280D, CM-600, CM-600D, Modular Cogeneration Systems, Thermo Electron Corporation
- Tecogen CM-60, Cogeneration Module System Design Manual, Thermo Electron Corporation

The above technical manuals provide information on the equipment parameters, including a general description of the system, component description, performance specifications, maintenance data, and related piping and instrumentation diagrams. These are the only available manuals at this time; however, other PCS suppliers should be consulted to determine the availability of similar manuals for other PCS units.

6.2.7 Packaging, Handling, Storage, and Transportation

PCS equipment will be packaged according to best commercial practice, handled by commercial carriers, and transported by commercial carriers. The manufacturer will be responsible for the integrity of the PCS until it is installed on site and operational. Therefore, there is no need for the imposition of packaging, handling, storage, and transportation (PHS&T) requirements normally associated with equipment that will be eventually deployed with the fleet or Fleet Marine Forces.

Certain hazardous materials are used to operate and maintain the PCS. These include the following:

- Lubricant, Mobil DTE Heavy, Medium
- Lubricant, Type A, Automatic Transmission
- Sealant, Loctite
- Antiseize Compound
- Silicone Grease, Dow-Corning-4
- Thread Compound, Teflon
- Diesel Fuel
- Natural Gas
- Propane
- Antifreeze Coolant
- Battery Acid
- Refrigerant

The requirements for PHS&T of these materials may be extracted from the Code of Federal Regulations (CFR), Part 49.

6.3 Reliability, Availability, and Maintainability (RAM) for PCS

One of the key measures of PCS performance during its life is the RAM of the unit. It is important that, before selecting a PCS unit for an application, the RAM information on that class (size and type) of PCS be known to the engineer. This information will facilitate obtaining the maximum output from the unit with the lowest operating cost and minimum disruption in operation.

For large-sized cogeneration units (over 1000 kW), a large amount of information on the operation of the units already exists (Ref 11). The RAM information is also available for these units. However, for a small PCS, the RAM information is almost nonexistent. This is primarily because small PCSs have been developed only in the last four to five years. They are becoming more popular, especially among the small institutional and commercial building operators, small industrial users, and on military bases. Many people who have to make decisions on selecting and sizing PCSs do not have the capability or the resources to learn, collect, and use RAM information on the PCS. As a result there is a concern that they may make decisions on PCS which will lead to poor RAM for the unit later. The main purpose of this analysis is to provide RAM information to this segment of the cogeneration community.

For the reasons given above, a RAM analysis was performed for PCSs which have been in actual operation. Several sites were selected where PCSs were in operation providing electricity and thermal output. The cogeneration units at these sites consisted of various sizes, types of engines (industrial and automotive), manufacturers, and applications. Data on the operation of the units were collected from the maintenance log books of the units. Additional data collected by EPRI/SRC on the operation of the small cogeneration units have also been used in this analysis.

6.3.1 Methodology Used in the Analysis

A. Approach

This analysis includes a PCS RAM data base that can be used by Navy engineers in the selection and operation of a PCS. The RAM of a PCS depends on several configuration and operating parameters. Important among these are the size, complexity of the unit, duty cycle, operation and maintenance schedule, and usage pattern. To insure a thorough analysis, it is necessary to collect data for these parameters.

In order to perform the RAM analysis for the UDP, two RAM data bases were developed. The first data base contained general specification-type information, and the second data base consisted of detailed operation and maintenance information. This information was analyzed to develop guidelines for the Navy in the selection, operation, and maintenance of small packaged cogeneration systems.

B. Data Sources

The data used in the RAM analysis were collected primarily during site visits. A total of 91 sites were visited by the Navy and EPRI. A majority of these sites had cogeneration units with a capacity under 500 kW. However, there were units as large as 800 kW at some sites. In addition, data from earlier EPRI (Ref 6), NCEL (Ref 13), and other (Ref 12) cogeneration studies were also used.

The cogeneration operation data were collected from the sites by interviewing the operators, examining the unit specifications, and reviewing the logbook maintained at the site. One of the important pieces of information was on the scheduled and unscheduled breakdown of the unit. Information on the various subsystems that needed more frequent repairs was also collected.

The first RAM data base has information on 91 cogeneration sites. The data include:

- General information
- Site-related data
- Cogeneration system data
- Operating data
- Maintenance and cost data
- Major reasons for failures

The second RAM data base has detailed information on the operation and maintenance of 18 cogeneration sites consisting of 27 cogeneration units. The key information consisted of the following:

- Preventive maintenance record
- Parts changed or cleaned during maintenance, hours spent
- Unscheduled maintenance record
- Subsystems repaired, hours spent

C. RAM Definitions

There are two standard techniques for defining RAM parameters. The IEEE Standard 762 definition is most commonly used by the utility industry. This definition is used by the North American Electric Reliability Council (NERC) in their Generating Availability Data System (GADS). The second standard is the Department of Defense Standard DOD 3235.1-H RAM Handbook. These definitions are shown in Figures 6.1 and 6.2. These RAM parameters are used by the industry for evaluating the reliability, availability, and maintainability of the cogeneration systems.

The definitions of the various RAM parameters according to the IEEE Standard 762 are given below (see Figure 6.1):

Availability is defined as the ratio of the available hours (service hours plus standby hours) to the period hours. Period hours are those hours where the unit is in an active state.

Service Factor is defined as the ratio of service hours, i.e., those hours when the system is operating under load, to the period hours.

Net Capacity Factor is the ratio of the total generated kWh to the kWh that could be generated if the system were operating at its rated capacity for all hours of the period.

Scheduled Outage Factor is the ratio of the scheduled maintenance time to the period hours.

Forced Outage Factor is the ratio of the unscheduled maintenance time to the period hours.

The definitions of RAM parameters defined by the Standard DOD 3235.1-H Handbook are very similar to the ones in the IEEE 762 handbook. These definitions are given below (see Figure 6.2):

Availability is defined as the ratio of the available hours (operating plus standby hours) to the potentially available hours.

Utilization Factor is the ratio of operating hours to the calendar hours.

Mean Time Between Failures (MTBF) is the total operating hours divided by total number of unscheduled outages.

Mean Time Between Maintenance (MTBMA) is the total operating hours divided by total number of scheduled outages.

Reliability for 720 hours is expressed as $\exp(-720/MTBF)$.

The RAM definitions based on Standard IEEE 762 handbook were used in the analysis of the annual data from the 91 sites, whereas the definitions based on DOD 3235.1 were used for the detailed monthly analysis.

The IEEE scheduled and unscheduled outage factors can be related to the DOD MTBMA and MTBF if the number of scheduled and unscheduled outages during the potentially available hours (also called Period Hours) are known. The relation between these two standard definitions are given below:

$$\text{Scheduled Outage Factor} = 1/MTBMA * \text{Scheduled Outage Hr} / N_{pm} * 100$$

$$\text{Unscheduled Outage Factor} = 1/MTBF * \text{Unscheduled outage Factor} / N_{cm} * 100$$

where N_{pm} is the number of scheduled outages during the period hours and N_{cm} is the number of unscheduled outages during the period hours.

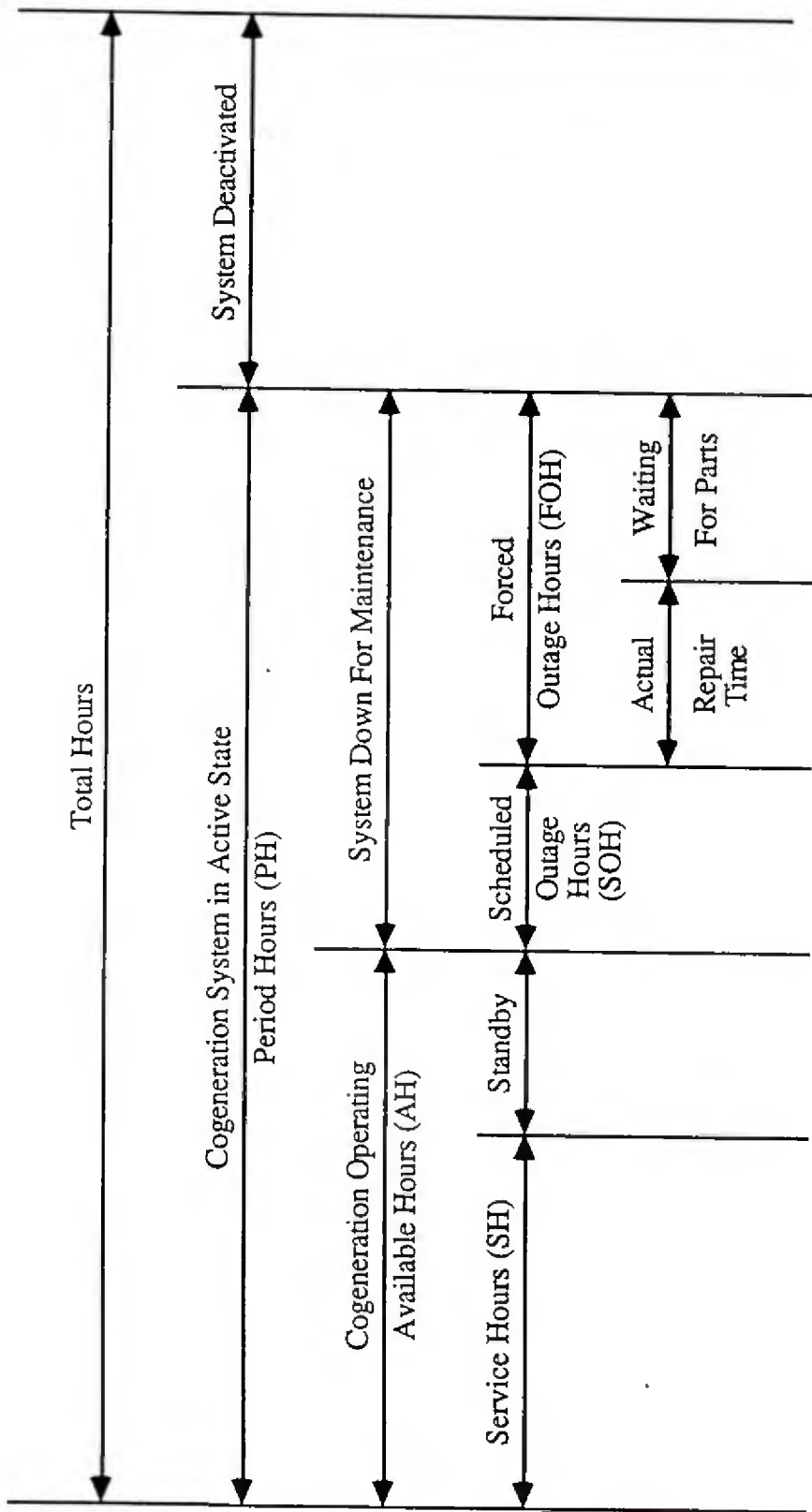

Availability = $AH / PH * 100\%$
 Service Factor = $SH / PH * 100\%$
 Net Output Factor = $[Net\ Output\ kWh / (SH * Unit\ kW\ Capacity)] * 100\%$
 Net Capacity Factor = $[Net\ Output\ kWh / (PH * Unit\ kW\ Capacity)] * 100\%$
 Forced Outage Rate = $[FOH / (FOH + SH)] * 100\%$
 Scheduled Outage Factor = $(SOH / PH) * 100\%$
 Forced Outage Factor = $(FOH / PH) * 100\%$

Figure 6.1 IEEE Standard 762 RAM Definition

| | | | |
|---|-------------|--------------------------------|---------------------------------------|
| A: Facility Operating Hours (Calendar Hours) | | | |
| B: Cogeneration System Potentially Available (Hours) | | | Scheduled |
| Cogeneration Available Hours | | System Down for Maint. (Hours) | |
| C: Operating Hours | D: Stand-by | E: Sched'd F: Unscheduled | |
| | Hours | (prevent. maint'ce) | (correct. maint.) Actual Waiting |
| | | Repair | for Parts (Down) |

Availability = Cogeneration Available Hours/Potentially Available Hours = (C+D) / B
 MTBMA (Mean Time Bet Maint) = Cogen Pot. Avl. Hours/No of Prev. Maint. = B/Num
 MTBF (Mean Time Between Failures) = Cogen Pot. Avl. Hours/No of Corr Maint. = B/Num
 Reliability (for 720 Hours) = $e^{-720/MTBF}$

Figure 6.2 Standard DOD 3235.1 RAM Definition

6.3.2 RAM Data Base

A. Distribution of the Sample

Of the 91 sites visited, 33 were in California, 11 in New Jersey, 8 in Connecticut, 7 each in Hawaii, Massachusetts, and Pennsylvania, 5 in New York, 4 each in Arizona and Michigan, 3 in Ohio, and 2 in Texas.

The various facilities served by the cogeneration units at these sites included apartments, hospitals, hotels/motels, factories, nursing homes, offices, sewage plants, recreational buildings, restaurants, schools/colleges, and supermarkets. A list of various facilities and number of sites with those facilities are shown in Table 6.3.

Table 6.3 Distribution of Systems by Facility Type

| Type of Facility | Number of Systems |
|--------------------------|-------------------|
| Apartment | 5 |
| Hospital | 14 |
| Hotel/Motel | 7 |
| Industrial | 21 |
| Nursing Home | 8 |
| Office | 2 |
| Gov/Pub/Mun/Sewage Plant | 6 |
| Recreational | 16 |
| Restaurant | 2 |
| School/College | 9 |
| Supermarket | 1 |
| Total | 91 |

There are seven applications where the recovered heat from the cogeneration units were used. These uses are for space heat, domestic hot water, laundry hot water, process hot water, process steam, absorption cooling, and pool heating.

More than two dozen manufacturer/packagegers were represented in the RAM data base. Some of the packagegers represented in larger numbers are: Tecogen, Cogenic, Waukesha, and Caterpillar. Some of the manufacturers included in the data base are no longer in business, as they have become insolvent or been purchased by others. A list of manufacturers and number of their units represented among the sites visited is shown in Table 6.4.

The size of the cogeneration units at these sites varied from 10 kW to 800 kW, whereas the system size at the sites varied from 10 kW to 2400 kW. A system can consist of single unit or several units. A table listing various size ranges and number of systems/units is shown in Table 6.5.

Table 6.4 Distribution of Systems by Manufacturer

| Manufacturer | Single-Unit Systems | Multiple-Unit Systems | Total |
|-----------------------|---------------------|-----------------------|-------|
| Tecogen | 25 | 27 | 52 |
| Caterpillar | 7 | 26 | 33 |
| Cummins | 4 | 0 | 4 |
| Waukesha | 4 | 21 | 25 |
| Solar Turbine | 3 | 1 | 4 |
| CFM | 2 | 11 | 13 |
| Cooper Superior | 1 | 0 | 1 |
| Coppus Steam Turbine | 1 | 0 | 1 |
| Empire | 1 | 2 | 3 |
| Gen Bach | 1 | 0 | 1 |
| M.A.N. | 1 | 0 | 1 |
| Minneapolis Moline | 1 | 0 | 1 |
| Thermex | 1 | 0 | 1 |
| Westinghouse | 1 | 0 | 1 |
| Dresser | 0 | 3 | 3 |
| Other | 4 | 6 | 10 |
| Total number of units | 57 | 97 | 154 |

Table 6.5 Distribution of Systems by Size and Number of Units

| System size (kW) | Number of Systems |
|------------------|-------------------|
| < 20 | 2 |
| 20 - 49 | 2 |
| 50 - 99 | 30 |
| 100 - 249 | 20 |
| 250 - 499 | 10 |
| 500 - 1000 | 15 |
| > 1000 | 13 |
| Total | 91 |

| Unit size (kW) | Number of Units |
|----------------|-----------------|
| < 20 | 6 |
| 20 - 49 | 1 |
| 50 - 99 | 57 |
| 100 - 249 | 31 |
| 250 - 499 | 28 |
| 500 - 1000 | 31 |
| > 1000 | 0 |
| Total | 154 |

B. RAM Analysis

The annual RAM data base consists of two sets of information. The first set includes information on the site, the utility, the facility, and the cogeneration system configuration. The second set of information includes all the data on the performance of the cogeneration system. The performance data include the hours of operation, hours and number of preventive and corrective maintenance, and various subsystems that needed to be repaired.

An analysis was performed on the data to determine how the RAM of the system is affected by various operation and maintenance variables such as the following:

- Size of the unit
- System configuration/complexity
- Type of prime mover
- Maintenance schedule and contract
- Utility connection
- Years of service

Cogeneration System Size:

The results from the analysis are summarized in Tables 6.6 to 6.11. There are several important points observed from these results. As for the size of the systems, larger systems generally have higher availability and service factors. This is primarily because sites with large systems tend to have some personnel always present at the site who can take care of minor problems or quickly alert the maintenance people when there are unexpected problems. Smaller units tend to be located at sites which are usually unmanned, and in case of minor unexpected problems the units tend to be down for a longer time. However, there are no strong trends showing increased availability and service factor with the size of the systems. Similar observations were made in an earlier study by EPRI (Ref 6).

System Configuration:

The results shown in Table 6.6 indicate that, generally, complex systems tend to have lower RAM compared to simple systems. Similar trends were also shown in an earlier EPRI study (Ref 6). This is primarily because there are more subsystems that may fail and need to be repaired. Systems with emission controls have an availability of 78 percent and a service factor of 50 percent, whereas those without emission controls have 89 percent and 64 percent, respectively. The availability of cogeneration systems with absorption chillers is 87 percent; and without chiller, 88 percent; whereas the service factor is 70 percent with chiller and 66 percent without the chiller.

Table 6.6 Availability and Service Factor by Emission Controls and by Absorption Chillers

| | Availability (%) | Service Factor (%) |
|--------------------|------------------|--------------------|
| Emission Controls | | |
| With Controls | 78.2 | 49.7 |
| Without Controls | 88.7 | 63.9 |
| Absorption Chiller | | |
| With Chiller | 87.0 | 70.4 |
| Without Chiller | 88.0 | 66.0 |

Type of Prime Mover:

The effect of type of prime mover, automotive or industrial, on the RAM of the system was not significant. The cogeneration systems with industrial-type engines have marginally higher availability and service factors (2 to 3 percentage points).

Maintenance Schedule:

A majority of the systems visited had maintenance contracts with the packager or a third party. Of the 91 sites, only 19 did not have a contract and took care of the maintenance themselves. The availability and service factor for these two arrangements are shown in Table 6.7. For single-unit systems, the availability was higher with a maintenance contract (87.3 percent vs. 81 percent without contract); however, for multiple-unit systems, it was lower with a maintenance contract (85 percent vs. 95 percent without a contract). This is because large multiple-unit systems without contracts tend to have their staff members available around the clock to respond when problems arise and are equipped to repair any minor problems. These facilities do not need a maintenance contract and call outside firms only for specialized work. The single-unit systems, however, are usually located in small facilities and do not have any staff to continuously monitor the system.

Utility Connection and System Operating Mode:

Examining the RAM data of the systems with four different arrangements of interchange with the utility, the systems which operate in the "buy deficit only" arrangement have the highest service factor and second highest availability factor. About half of the systems operate in this mode. This arrangement is the least complex (next to the isolated arrangement) among all

the arrangements and least prone to interruptions. The results are shown in Table 6.8.

More than half of the systems surveyed follow thermal load, whereas about a quarter generate maximum electricity (base loaded). The systems operating in base-loaded mode have higher availability and service factors. The data for all the modes are shown in Tables 6.9a and 6.9b.

Table 6.7 Average Availability and Service Factor of PCS by Presence of Maintenance Contract

| Single-Unit Systems | Availability | Number of Observations |
|---------------------------|--------------|------------------------|
| With Maintenance Contract | 87.3% | 47 |
| W/O Maintenance Contract | 81.0% | 6 |
| Missing | | 4 |
| Total | | 57 |
| Multi-Unit Systems | Availability | Number of Observations |
| With Maintenance Contract | 85.0% | 24 |
| W/O Maintenance Contract | 95.0% | 9 |
| Missing | | 1 |
| Total | | 34 |

| Single-Unit Systems | Service Factor | Number of Observations |
|---------------------------|----------------|------------------------|
| With Maintenance Contract | 68.0 % | 49 |
| W/O Maintenance Contract | 65.6 % | 5 |
| Missing | | 3 |
| Total | | 57 |
| Multi-Unit Systems | Service Factor | Number of Observations |
| With Maintenance Contract | 71.7 % | 23 |
| W/O Maintenance Contract | 74.7 % | 8 |
| Missing | | 3 |
| Total | | 34 |

Table 6.8 Average Availability and Service Factor
by Power Interchange with the Utility

| Mode of Interchange | Single-Unit System | | Multiple-Unit Systems | |
|-------------------------|------------------------|------------------------|------------------------|------------------------|
| | Average Service Factor | Number of Observations | Average Service Factor | Number of Observations |
| Isolated | 56.0 % | 2 | 36.1 % | 2 |
| Buy Deficit Only | 70.7 % | 28 | 81.7 % | 17 |
| Sell Excess/Buy Deficit | 63.7 % | 17 | 79.5 % | 2 |
| Simultaneous Buy/Sell | 58.3 % | 4 | 64.3 % | 7 |
| Missing | | 6 | | 6 |
| Total | | 57 | | 34 |

| Mode of Interchange | Single-Unit Systems | | Multiple-Unit Systems | |
|-------------------------|----------------------|------------------------|-----------------------|------------------------|
| | Average Availability | Number of Observations | Average Availability | Number of Observations |
| Isolated | 93.8 % | 2 | 95.0 % | 2 |
| Buy Deficit Only | 90.0 % | 28 | 92.4 % | 17 |
| Sell Excess/Buy Deficit | 80.8 % | 17 | 89.8 % | 2 |
| Simultaneous Buy/Sell | 73.5 % | 3 | 73.4 % | 8 |
| Missing | | 7 | | 5 |
| Total | | 57 | | 34 |

Table 6.9a Average Availability of Small Cogeneration Systems by System Operating Mode

| Single-Unit Systems | | |
|-------------------------------------|--------------|------------------------|
| Mode of Operation | Availability | Number of Observations |
| Follow Thermal Load | 85.9 % | 30 |
| Follow Electric Load | 91.7 % | 3 |
| Generate Max Electric (baseload) | 90.0 % | 14 |
| Generate Max Electric (sell excess) | 78.2 % | 3 |
| Peak Shaving | 81.3 % | 3 |
| Missing | | 4 |
| Total | | 57 |
| Multiple-Unit Systems | | |
| Mode of Operation | Availability | Number of Observations |
| Follow Thermal Load | 91.8 % | 16 |
| Follow Electric Load | 96.7 % | 3 |
| Generate Max Electric (baseload) | 88.7 % | 7 |
| Generate Max Electric (sell excess) | 67.2 % | 6 |
| Peak Shaving | 95.4 % | 2 |
| Total | | 34 |

Table 6.9b Average Service Factor of Small Cogeneration Systems by Operating Mode

| Single-Unit Systems | | |
|-------------------------------------|----------------|------------------------|
| Mode of Operation | Service Factor | Number of Observations |
| Follow Thermal Load | 61.2 % | 29 |
| Follow Electric Load | 92.3 % | 3 |
| Generate Max Electric (baseload) | 78.0 % | 16 |
| Generate Max Electric (sell excess) | 74.7 % | 3 |
| Peak Shaving | 49.7 % | 3 |
| Missing | | 3 |
| Total | | 57 |
| Multiple-Unit Systems | | |
| Mode of Operation | Service Factor | Number of Observations |
| Follow Thermal Load | 77.7 % | 15 |
| Follow Electric Load | 67.0 % | 3 |
| Generate Max Electric (baseload) | 83.1 % | 7 |
| Generate Max Electric (sell excess) | 61.1 % | 6 |
| Peak Shaving | 40.0 % | 2 |
| Missing | | 1 |
| Total | | 34 |

Years of Service:

The data on the availability and service factor by operating and calendar year are shown in Tables 6.10a and 6.10b. The data show that these factors have been steadily increasing by calendar year. The average factors for multiple-unit systems are higher than single-unit system, due to the redundancy of the multiple-unit systems.

Table 6.10a Average Availability of Small Cogeneration Units by Year of Operation by Calendar Year

| Single-Unit Systems | | | Multiple-Unit Systems | | |
|---------------------|----------------------|------------------------|-----------------------|----------------------|------------------------|
| Operating Year | Average Availability | Number of Observations | Operating Year | Average Availability | Number of Observations |
| 1 | 86.0 % | 33 | 1 | 82.0 % | 44 |
| 2 | 85.0 % | 32 | 2 | 89.0 % | 44 |
| 3 | 84.0 % | 22 | 3 | 85.0 % | 32 |
| 4 | 82.0 % | 9 | 4 | 88.0 % | 28 |
| 5 | 87.0 % | 5 | 5 | 97.0 % | 9 |
| 6 | 90.0 % | 5 | 6 | 98.0 % | 7 |
| Average | 86.0 % | | | 89.0 % | |

| Single-Unit Systems | | | Multiple-Unit Systems | | |
|---------------------|----------------------|------------------------|-----------------------|----------------------|------------------------|
| Calendar Year | Average Availability | Number of Observations | Calendar Year | Average Availability | Number of Observations |
| 1985 | 77.0 % | 8 | 1985 | 81.0 % | 25 |
| 1986 | 87.0 % | 15 | 1986 | 96.0 % | 27 |
| 1987 | 87.0 % | 36 | 1987 | 88.0 % | 60 |
| 1988 | 87.0 % | 49 | 1988 | 90.0 % | 91 |
| Average | 86.0 % | | | 89.0 % | |

Table 6.10b Average Service Factor of Small Cogeneration Systems by Year of Operation by Calendar Year

| Single-Unit Systems | | | Multiple-Unit Systems | | |
|---------------------|----------------|------------------------|-----------------------|----------------|------------------------|
| Operating Year | Service Factor | Number of Observations | Operating Year | Service Factor | Number of Observations |
| 1 | 71.0 % | 34 | 1 | 64.0 % | 44 |
| 2 | 65.0 % | 33 | 2 | 77.0 % | 44 |
| 3 | 62.0 % | 23 | 3 | 69.0 % | 32 |
| 4 | 61.0 % | 9 | 4 | 77.0 % | 28 |
| 5 | 53.0 % | 5 | 5 | 72.0 % | 9 |
| 6 | 63.0 % | 5 | 6 | 67.0 % | 7 |
| Average | 66.0 % | | | 67.0 % | |

| Single-Unit Systems | | | Multiple-Unit Systems | | |
|---------------------|----------------|------------------------|-----------------------|----------------|------------------------|
| Calendar Year | Service Factor | Number of Observations | Year | Service Factor | Number of Observations |
| 1985 | 53.0 % | 8 | 1985 | 55.0 % | 25 |
| 1986 | 66.0 % | 15 | 1986 | 62.0 % | 27 |
| 1987 | 68.0 % | 37 | 1987 | 65.0 % | 60 |
| 1988 | 67.0 % | 51 | 1988 | 74.0 % | 90 |
| Average | 66.0 % | | | 67.0 % | |

Failure Analysis:

The two important RAM parameters are the scheduled and forced outage factors. The data for the scheduled outage factor are shown in Table 6.11a. An average of 1 percent of the period hours are spent in scheduled maintenance for both single-unit and multiple-unit systems. However, the time spent on maintenance increases with the age of the system. The forced outage factor for the surveyed systems, shown in Table 6.11b, is about an order of magnitude larger than the scheduled outage factor. For single-unit systems this factor is 11 percent, and for multi-unit systems it is 8.8 percent.

A failure analysis of the data from the 91 sites as shown in Table 6.12 indicates that most problems causing failures of small cogeneration systems were system design or performance

oriented. There were some cases where operator or maintenance personnel carelessness was cited.

The most commonly mentioned reasons for failures were minor problems such as leaking oil and loose connections. These were followed by problems with the water pumping system, either in the primary or the secondary loops. The next most frequent response was control problems causing the electronic panels to burn out. A total of 30 sites reported utility-related problems, both electric and gas, for failures. In 20 cases, the electric power brownouts or voltage dips caused the cogeneration system to trip and the systems had to be manually reset. In ten cases the problems were related to the gas supply. The next set of reasons was related to heat recovery boilers, engine/turbocharger problems, and engine oil level/pressure problems. Each of these reasons were reported by 17 sites. Starter and generator were the next highest categories, reported by 13 and 11 sites, respectively.

Table 6.11a Scheduled Outage Factor Data

| Single-Unit Systems | | | Multiple-Unit Systems | | |
|---------------------|-------------------------|------------------------|-----------------------|-------------------------|------------------------|
| Operating Year | Scheduled Outage Factor | Number of Observations | Operating Year | Scheduled Outage Factor | Number of Observations |
| 1 | .65 % | 33 | 1 | .74 % | 44 |
| 2 | 1.01 % | 32 | 2 | .60 % | 44 |
| 3 | 1.05 % | 22 | 3 | 1.21 % | 32 |
| 4 | .99 % | 9 | 4 | 2.01 % | 28 |
| 5 | 1.36 % | 5 | 5 | 1.06 % | 9 |
| Average | | .97 % | 1.01 % | | |

| Single-Unit Systems | | | Multiple-Unit Systems | | |
|---------------------|-------------------------|------------------------|-----------------------|-------------------------|------------------------|
| Year | Scheduled Outage Factor | Number of Observations | Year | Scheduled Outage Factor | Number of Observations |
| 1985 | 1.07 % | 8 | 1985 | 1.05 % | 25 |
| 1986 | .79 % | 15 | 1986 | .71 % | 27 |
| 1987 | 1.06 % | 36 | 1987 | .92 % | 60 |
| 1988 | .94 % | 49 | 1988 | .92 % | 91 |
| Average | | .97 % | 1.01 % | | |

Table 6.11b Forced Outage Factor Data

| Single-Unit Systems | | | Multiple-Unit Systems | | |
|---------------------|----------------------|------------------------|-----------------------|----------------------|------------------------|
| Operating Year | Forced Outage Factor | Number of Observations | Operating Year | Forced Outage Factor | Number of Observations |
| 1 | 12.4 % | 33 | 1 | 16.6 % | 44 |
| 2 | 13.1 % | 32 | 2 | 9.5 % | 44 |
| 3 | 14.0 % | 22 | 3 | 13.1 % | 32 |
| 4 | 16.5 % | 9 | 4 | 9.3 % | 28 |
| Average | 11.0 % | | | 8.8 % | |

| Single-Unit Systems | | | Multiple-Unit Systems | | |
|---------------------|----------------------|------------------------|-----------------------|----------------------|------------------------|
| Year | Forced Outage Factor | Number of Observations | Year | Forced Outage Factor | Number of Observations |
| 1985 | 15.8 % | 5 | 1985 | 16.6 % | 22 |
| 1986 | 11.1 % | 12 | 1986 | 1.0 % | 20 |
| 1987 | 6.3 % | 22 | 1987 | 11.1 % | 28 |
| 1988 | 13.9 % | 29 | 1988 | 7.2 % | 49 |
| Average | 11.0 % | | | 8.8 % | |

Table 6.12 Failure Analysis - Number Of Sites Reporting Failures

| Subsystem | Total No. of Sites | Maint. Contract | | No. of Units | | Configuration | | Year of Startup | | | | | Operating Mode | |
|---------------------------------|--------------------|-----------------|---------|--------------|-------|----------------------|------------|-----------------|------|-----------|------|------|-------------------|-------------------|
| | | With | Without | Single | Multi | w/Absorption Cooling | w/Emission | Pre 1983 | 1983 | 1984-1986 | 1987 | 1988 | Thermal Following | Constant Electric |
| Minor Problems | 40 | 36 | 4 | 24 | 16 | 10 | 6 | 7 | 4 | 14 | 14 | 1 | 24 | 12 |
| Engine/Turbocharger | 17 | 15 | 2 | 11 | 6 | 8 | 5 | 2 | 2 | 10 | 3 | 0 | 6 | 8 |
| Control System | 22 | 20 | 2 | 14 | 8 | 7 | 3 | 1 | 1 | 9 | 9 | 2 | 11 | 8 |
| Starting | 13 | 12 | 1 | 8 | 5 | 2 | 1 | 1 | 1 | 6 | 4 | 1 | 9 | 3 |
| Heat Recovery | 17 | 15 | 2 | 11 | 6 | 2 | 2 | 2 | 2 | 6 | 6 | 1 | 12 | 3 |
| Generator | 11 | 10 | 1 | 6 | 5 | 1 | 3 | 0 | 2 | 6 | 3 | 0 | 6 | 4 |
| Emissions Control | 5 | 5 | 0 | 2 | 3 | 4 | 5 | 0 | 0 | 4 | 1 | 0 | 0 | 4 |
| Related to Water Pumping | 32 | 27 | 5 | 19 | 13 | 8 | 5 | 4 | 4 | 11 | 10 | 3 | 17 | 9 |
| Engine Oil Pressure/Level | 16 | 15 | 1 | 12 | 4 | 4 | 3 | 2 | 2 | 8 | 3 | 1 | 7 | 5 |
| Corrosion | 8 | 6 | 2 | 3 | 5 | 5 | 3 | 3 | 0 | 2 | 3 | 0 | 5 | 0 |
| Natural Gas Supply Related | 10 | 6 | 4 | 5 | 5 | 4 | 0 | 4 | 1 | 3 | 0 | 2 | 4 | 5 |
| Utility Interconnection Related | 20 | 17 | 3 | 14 | 6 | 6 | 5 | 2 | 1 | 7 | 7 | 3 | 11 | 6 |
| Excitor/Voltage Regulator | 5 | 5 | 0 | 3 | 2 | 2 | 0 | 3 | 1 | 1 | 0 | 0 | 2 | 1 |
| Magneto | 5 | 4 | 1 | 3 | 2 | 2 | 2 | 2 | 0 | 3 | 0 | 0 | 4 | 0 |
| Battery | 5 | 5 | 0 | 3 | 2 | 0 | 0 | 0 | 1 | 2 | 1 | 1 | 3 | 2 |
| Lube Oil | 6 | 6 | 0 | 4 | 2 | 3 | 1 | 1 | 1 | 2 | 2 | 0 | 1 | 2 |
| Air Cooler | 4 | 2 | 2 | 2 | 2 | 2 | 0 | 1 | 0 | 1 | 1 | 1 | 4 | 1 |
| Gear Box | 2 | 1 | 1 | 1 | 1 | 2 | 0 | 1 | 0 | 1 | 0 | 0 | 1 | 0 |
| Governor | 5 | 4 | 1 | 2 | 3 | 3 | 0 | 2 | 0 | 2 | 1 | 0 | 3 | 1 |
| Output Breaker | 1 | 1 | 0 | 1 | 0 | 0 | 0 | 0 | 0 | 1 | 0 | 0 | 1 | 0 |

C. Detailed RAM Data

The monthly data on the operation of the 27 cogeneration units at 18 sites were analyzed to get an in-depth understanding of the RAM of PCS. These sites were a subset of the 91 sites described earlier and had detailed information of the operation of the cogeneration systems at the sites. In this section, the definitions of the RAM terms given in DOD 3235.1 are also used with the IEEE Standard 762 definitions.

In this detailed analysis, emphasis was placed on the following:

- Influence of the size of the unit on RAM
- Effect of maintenance frequency on RAM
- Identification of subsystems that are prone to breakdown
- Identification of any clear patterns in the data for achieving better RAM

In order to see whether the size of the units has any effect on the RAM of the system, the detailed data were analyzed and the results are shown in Table 6.13. The analysis on 27 PCS units shows that the availability varies between 66 percent and 90 percent and the service factor varies from 41 percent to 68 percent. The MTBF for these units varied from 750 to 1150 hours, with an average of 820 hours for the whole group. The MTBMA varied from 740 to 1440 hours, with an average for the whole group of about 910 hours.

Because the record keeping and the quality of data for the 18 sites were not consistent, it was difficult to make any generalization based on these results. However, the results shown in Table 6.13 indicate certain trends. One of these trends is that the units with low MTBMA have high availability and units with high MTBMA have lower availability numbers. More frequent scheduled maintenance increases the availability of the unit irrespective of unit's size. For one set of units with an average MTBMA of 743 hours, the availability number was 90 percent, whereas for another set with an MTBMA of 1436 hours, the availability number was 67 percent.

An examination of the subsystem breakdown of the 27 PCS units showed that the subsystems needing to be repaired most frequently are engine related, cooling related, control, heat recovery systems, and the generator. In Table 6.14, a breakdown of various subsystems requiring the most frequent repairs is shown for three size ranges.

Table 6.13 Impact of Unit Size on RAM

| RAM Parameter | --- Cogeneration Unit Size Range (kW) --- | | |
|--|---|----------|-----------|
| | 0 to 10 | 11 to 75 | 76 to 125 |
| No. of Observations | 9 | 36 | 9 |
| Scheduled Outage Factor, % | .116 | .362 | .340 |
| Forced Outage Factor, % | .341 | .573 | .640 |
| Mean Time Bet. Maint., hrs (MTBMA) | 1436 | 743 | 1062 |
| Mean Time Bet. Failures, hrs (MTBF) | 773 | 753 | 1158 |
| Reliability for 720 hours, % | 34.5 | 30.7 | 41.5 |
| Availability, % | 66.6 | 89.5 | 78.3 |
| Service Factor, % | 40.6 | 53.6 | 68.1 |
| Mean Time to Maintain, hrs (MTTM) | 1.4 | 2.4 | 2.4 |
| Mean Time to Repair, hrs (MTTR) | 2.0 | 2.6 | 7.4 |

Table 6.14 Subsystems Requiring Frequent Repair

| Sub-system | --- Cogeneration Unit Size Range (kW) --- | | |
|--|---|----------|-----------|
| | 0 to 10 | 11 to 75 | 76 to 125 |
| No of Observations | 9 | 36 | 9 |
| Total Calendar Hours | 40,992 | 230,688 | 65,256 |
| Total Operating Hours | 16,839 | 121,992 | 46,328 |
| <u>Number of Repairs</u> (per unit per 1,000 operating hours) | | | |
| All Sub-systems | 3.27 | 4.57 | 2.41 |
| Engine | 1.37 | .42 | .15 |
| Control | .24 | .43 | .22 |
| Cooling | .83 | 2.15 | .76 |
| Heat Recovery | .18 | .34 | .17 |
| Generator | .30 | .52 | .02 |

6.3.3 Summary of Major Findings

Several major findings came out of the RAM analysis. These findings can be used by Navy engineers as a guide in the selection and operation of PCSs. The findings will also assist engineers in ensuring that they get the highest RAM for their PCS.

1. Availability

The average RAM parameters of the 91 sites surveyed are as follows: availability of 87.1 percent, service factor of 66.3 percent, scheduled outage factor of 0.98 percent, and forced outage factor of 10.1 percent. The availability of a PCS does not seem to be strongly influenced by the size of the unit; rather, how well the unit is maintained and operated is more important to obtaining better availability for the unit. For a given size of system, multi-unit systems provide a marginally better availability as compared to single-unit system.

2. Maintenance

Regular maintenance helps in maximizing the equipment availability and overall plant efficiency by reducing the number of unscheduled outages. In this aspect, the plants with a maintenance contract had higher availability than those without (87.3 percent vs. 81 percent). The cogeneration plants with their own maintenance personnel present in the plant during the operation of the plant had even higher availability (95 percent).

Reducing the time between scheduled maintenance increases the unit's availability; one set of units with an average MTBMA of 743 hours had an average availability of 90 percent, whereas another set of units with an average MTBMA of 1436 hours had an average availability of 67 percent.

3. Reliability

A reliability analysis of 18 sites, for which extensive data were available, showed that the average reliability for 720 hours was 33 percent. The reliability of the individual sites varied from as low as 1 percent to as high as 84 percent. The average MTBMA and MTBF for these sites were 910 and 820 hours, respectively. Just as availability increases with more frequent scheduled maintenance, the reliability also improves with increases maintenance. By lowering the MTBMA hours, the MTBF hours are increased, which leads to higher reliability.

4. Major Causes of Unscheduled Outages

Most of the unscheduled outages were due to mechanical and electrical problems. Some of the outages were due to one-time problems occurring due to unforeseen situations, whereas others were due to design or installation-related defects. However, these types of problems are usually remedied within several months of startup. The most common cause of system outage was high return-water temperature, which is caused by insufficient thermal loads and the inability of the system to dump heat.

Certain subsystems are more prone to breakdown than others. The subsystems with the largest number of failures were (in descending order): water pump, control system, utility interconnection, engine oil pressure/level, heat recovery system, starter, and generator.

ACKNOWLEDGMENTS

The author wishes to thank Sharon deMonsabert, Ph.D., for her participation in the preparation of this document.

REFERENCES

1. Davidson, K., "National Potential for cogeneration in the Commercial Sector," ASHRAE/ICS Fourth Annual Cogeneration Seminar, San Diego, CA, June 1984.
2. "Small Cogeneration System Availability Database," Draft report prepared by Synergic Resources Corporation for Electric Power Research Institute (Research Project RP2950-1), Palo Alto, CA, 1989.
3. "The COMMEND Planning System: National and Regional Data Analysis," Report No. EPRI EM-4486, Electric Power Research Institute, Palo Alto, CA, March 1986.
4. "Handbook of Industrial Cogeneration," DOE/TIC-11605, TRW Energy Engineering Division, McLean, VA, 1981.
5. Atkins, Richard, "Environmental Issues and Permitting Requirements for Packaged Cogeneration Facilities," Environmental Risk Limited. Presented at 2nd National Conference on Packaged Cogeneration Systems, San Diego, CA, 14-16 February 1989.
6. Gerber, D.C., "Small Cogeneration System Costs and Performance," ERPI EM-5954, Science Applications International Corporation, San Diego, CA, 1988.
7. Evatt, Nim, "Maintenance of Packaged Cogeneration Systems," International Cogeneration Corporation. Presented at 2nd National Conference on Packaged Cogeneration Systems, San Diego, CA, 14-16 February 1989.
8. Mulloney, J. Jr. and Knable, S., "Cost Drivers Affecting Gas-Fired Prepackaged Cogeneration Systems," The Cogeneration Journal, Vol. 3, No. 3., Summer 1988.
9. Limaye, D., "Packaged Cogeneration Technology and Economics," Seminar Notes prepared by Synergic Resources Corporation for Associated Energy Engineers, April 1988.
10. "Cost Reduction in the Manufacture and Installation of Gas-Fired Prepackaged Cogeneration Systems," Report prepared by Muller Associates, Inc. for Gas Research Institute, Report No. GRI-88/0053, November 1987.

11. Smith, C., Donovan, M., and Bartos, M., "Reliability Survey of Diesel and Gas Turbine Generating Units," paper No. 89CH2738-3, Industrial and Commercial Power Systems Technical Conference, IEEE, Chicago, IL, March 1989.
12. Limaye, D., "Operating Report: Packaged Cogeneration Systems," PP 6-11, The Cogeneration Journal. Vol. 4, No. 3, Summer 1989.
13. "Initial Feasibility Report on Decentralized Small Cogeneration for Navy Shore Bases," Naval Civil Engineering Laboratory, Contract Report, CR 84.018, February 1984.

Appendix A

LIST OF CANDIDATE PCS APPLICATIONS

| EFD | UIC | ACTIVITY | DIFF (\$/MBtu) | FACHUM | FACHUM | CCN | BUILDING TYPE DESCRIPTION | THERMAL TYPE (Kbtu/hr) |
|-------|--------|-------------------------------|-------------------|--------|---------------------------|-------|----------------------------|---------------------------|
| SOUTH | M67021 | HDQTRS 4TH MAM NEW ORLEANS LA | 17.41 | 1 | HANGAR 1 | 17115 | RESERVE TRAINING BUILDING | 239.60 |
| SOUTH | M68479 | HDQTRS 4TH MARDIV NEW ORLEANS | 18.46 | 1 | RESERVE TRAINING BLDG | 17115 | RESERVE TRAINING BUILDING | 134.91 |
| SOUTH | M68479 | HDQTRS 4TH MARDIV NEW ORLEANS | 18.46 | 1 | RESERVE TRAINING BUILDING | 17115 | RESERVE TRAINING BLDG | 157.70 |
| SOUTH | M68479 | HDQTRS 4TH MARDIV NEW ORLEANS | 18.46 | 1 | RESERVE TRAINING BLDG. | 17115 | RESERVE TRAINING BLDG. | 110.38 |
| SOUTH | M68479 | HDQTRS 4TH MARDIV NEW ORLEANS | 18.46 | 1 | RESERVE TRAINING BLDG | 17115 | RESERVE TRAINING BUILDING | 138.31 |
| SOUTH | M68479 | HDQTRS 4TH MARDIV NEW ORLEANS | 18.46 | 21 | HANGAR 21 | 17110 | MARINE RESERVE CENTER | 430.82 |
| SOUTH | M68479 | HDQTRS 4TH MARDIV NEW ORLEANS | 18.46 | 21 | HANGAR 21 | 17110 | ACADEMIC INSTRUCTION BLDG | 430.82 |
| SOUTH | M68479 | HDQTRS 4TH MARDIV NEW ORLEANS | 18.46 | 1 | RESERVE TRAINING BLDG | 17115 | RESERVE TRAINING BUILDING | 196.24 |
| SOUTH | N00213 | NAS KEY WEST FL | 17.30 | C-2076 | BOQ W/MESS | 72411 | BOQ,W-1/O-2 | 201.59 |
| SOUTH | N00213 | NAS KEY WEST FL | 17.30 | A-515 | MESS HALL-HOBBY SHOP | 72210 | ENLISTED DINING FACILITY | 323.58 |
| SOUTH | N00213 | NAS KEY WEST FL | 17.30 | 1287 | SUBSISTENCE BUILDING | 72210 | ENLISTED DINING FACILITY | 189.57 |
| SOUTH | N00213 | NAS KEY WEST FL | 17.30 | 136 | SHIPFITTER SHOP-ADMIN OFF | 61010 | ADMINISTRATIVE OFFICE | 126.01 |
| SOUTH | N00213 | NAS KEY WEST FL | 17.30 | 290 | SOWAR SCHOOL | 61010 | ADMINISTRATIVE OFFICE | 139.85 |
| SOUTH | N00213 | NAS KEY WEST FL | 17.30 | 8-48 | ORDNANCE RD/T BLDG | 17120 | APPLIED INSTRUCTION BLDG | 157.22 |
| LANT | N32960 | NAVSUPO LA MADDALENA IT | 25.13 | 300H | ENLISTED 1,2&3 BR UNITS | 71135 | LEASED HSG ENL QUARTERS | 184.39 |
| LANT | N62481 | NAS BERMUDA | 37.17 | A25 | SUBSISTENCE BUILDING | 72210 | FISH FACTORY | 239.08 |
| LANT | N62481 | NAS BERMUDA | 37.17 | 631 | MESS HALL | 72210 | ENLISTED DINING FACILITY | 225.32 |
| LANT | N62863 | NAVSTA ROTA SP | 16.23 | 39 | UOPH/DENTAL CLINIC | 72411 | BOQ,W-1/O-2 | 149.16 |
| LANT | N62863 | NAVSTA ROTA SP | 16.23 | 38 | EM DINING FAC | 72210 | ENLISTED DINING FACILITY | 587.84 |
| LANT | N62863 | NAVSTA ROTA SP | 16.23 | 380 | EM GALLEY | 72210 | ENLISTED DINING FACILITY | 128.22 |
| LANT | N63032 | NAS KEFLAVIK IC | 15.05 | 743 | ENLISTED DINING FACILITY | 72210 | ENLISTED DINING FACILITY | 159.56 |
| LANT | N63032 | NAS KEFLAVIK IC | 15.05 | 2431 | MESS HALL | 72210 | ENLISTED DINING FACILITY | 202.49 |
| LANT | N63032 | NAS KEFLAVIK IC | 15.05 | 2708 | MESS HALL | 72210 | ENLISTED DINING FACILITY | 112.46 |
| LANT | N63032 | NAS KEFLAVIK IC | 15.05 | 670 | MOQ 1 | 71131 | FUND HSG,1950/69,WO,0-1/03 | 164.68 |
| LANT | N63032 | NAS KEFLAVIK IC | 15.05 | 672 | MOQ #3 | 71132 | FUND HSG,1950/69,0-4,0-5 | 105.99 |
| LANT | N63032 | NAS KEFLAVIK IC | 15.05 | 951 | MEMQ | 71130 | FUND HSG,1950/69,ENLISTED | 184.58 |
| LANT | N63032 | NAS KEFLAVIK IC | 15.05 | 950 | MEMQ | 71130 | FUND HSG,1950/69,ENLISTED | 221.27 |
| LANT | N63032 | NAS KEFLAVIK IC | 15.05 | 952 | MEMQ NO 2 | 71130 | FUND HSG,1950/69,ENLISTED | 156.73 |
| LANT | N63032 | NAS KEFLAVIK IC | 15.05 | 953 | MEMQ #1 | 71130 | FUND HSG,1950/69,ENLISTED | 156.73 |
| LANT | N63032 | NAS KEFLAVIK IC | 15.05 | 960 | MEMQ 5 | 71130 | FUND HSG,1950/69,ENLISTED | 156.73 |
| LANT | N63032 | NAS KEFLAVIK IC | 15.05 | 961 | MEMQ 8 | 71130 | FUND HSG,1950/69,ENLISTED | 195.97 |
| LANT | N63032 | NAS KEFLAVIK IC | 15.05 | 962 | MEMQ 7 | 71130 | FUND HSG,1950/69,ENLISTED | 156.73 |
| LANT | N63032 | NAS KEFLAVIK IC | 15.05 | 963 | MEMQ 6 | 71130 | FUND HSG,1950/69,ENLISTED | 156.73 |
| LANT | N63032 | NAS KEFLAVIK IC | 15.05 | 926 | MEMQ | 71170 | FUND HSG,AFTER 69,ENLISTED | 156.73 |
| LANT | N63032 | NAS KEFLAVIK IC | 15.05 | 927 | MEMQ | 71170 | FUND HSG,AFTER 69,ENLISTED | 156.73 |
| LANT | N63032 | NAS KEFLAVIK IC | 15.05 | 928 | MEMQ | 71170 | FUND HSG,AFTER 69,ENLISTED | 156.73 |
| LANT | N63032 | NAS KEFLAVIK IC | 15.05 | 929 | MEMQ | 71170 | FUND HSG,AFTER 69,ENLISTED | 156.73 |
| LANT | N63032 | NAS KEFLAVIK IC | 15.05 | 930 | MEMQ | 71170 | FUND HSG,AFTER 69,ENLISTED | 156.73 |
| LANT | N63032 | NAS KEFLAVIK IC | 15.05 | 931 | MEMQ | 71170 | FUND HSG,AFTER 69,ENLISTED | 156.73 |
| LANT | N63032 | NAS KEFLAVIK IC | 15.05 | 914 | MEMQ | 71170 | FUND HSG,AFTER 69,ENLISTED | 215.08 |
| LANT | N63032 | NAS KEFLAVIK IC | 15.05 | 916 | MEMQ | 71170 | FUND HSG,AFTER 69,ENLISTED | 215.08 |
| LANT | N63032 | NAS KEFLAVIK IC | 15.05 | 918 | MEMQ | 71170 | FUND HSG,AFTER 69,ENLISTED | 215.08 |
| LANT | N63032 | NAS KEFLAVIK IC | 15.05 | 921 | MEMQ | 71170 | FUND HSG,AFTER 69,ENLISTED | 215.08 |
| LANT | N63032 | NAS KEFLAVIK IC | 15.05 | 922 | MEMQ | 71170 | FUND HSG,AFTER 69,ENLISTED | 143.39 |
| LANT | N63032 | NAS KEFLAVIK IC | 15.05 | 924 | MEMQ | 71170 | FUND HSG,AFTER 69,ENLISTED | 143.39 |
| LANT | N63032 | NAS KEFLAVIK IC | 15.05 | 925 | MEMQ | 71170 | FUND HSG,AFTER 69,ENLISTED | 215.08 |
| LANT | N63032 | NAS KEFLAVIK IC | 15.05 | 710 | HOSPITAL | 51010 | HOSPITAL | 496.00 |
| LANT | N65995 | NAVSUPPACT HOLY LOCH UK | 16.52 | | HAVERLEY UNITS 1-41 | 71135 | LEASED HSG,ENLISTED | 249.16 |
| LANT | N65995 | NAVSUPPACT HOLY LOCH UK | 16.52 | | HAVERLEY UNITS 55-95 | 71135 | LEASED HSG,ENLISTED | 251.70 |
| LANT | N65995 | NAVSUPPACT HOLY LOCH UK | 16.52 | | HAVERLEY UNITS 96-136 | 71135 | LEASED HSG,ENLISTED | 249.16 |
| LANT | N66691 | NAVSUPPACT SOUDA BAY GR | 16.10 | 2 | MULTI-USE BLDG | 72210 | ENLISTED DINING FACILITY | 149.49 |
| LANT | N66833 | NAVSTA PANAMA CANAL ROOMAN PN | 15.10 | 58 | MESS HALL-GALLEY | 72210 | ENLISTED DINING FACILITY | 169.85 |
| LANT | N66833 | NAVSTA PANAMA CANAL ROOMAN PN | 15.10 | 1226 | COMM/ADMIN BLDG | 61010 | ADMINISTRATIVE OFFICE | 132.78 |
| LANT | N66833 | NAVSTA PANAMA CANAL ROOMAN PN | 15.10 | 1220 | ADMINISTRATION BUILDING | 61010 | ADMINISTRATIVE OFFICE | 126.77 |
| LANT | N66833 | NAVSTA PANAMA CANAL ROOMAN PN | 15.10 | 1220 | ADMINISTRATION BUILDING | 61010 | ADMINISTRATIVE OFFICE | 126.77 |
| LANT | N66833 | NAVSTA PANAMA CANAL ROOMAN PN | 15.10 | 1220 | ADMINISTRATION BUILDING | 61010 | ADMINISTRATIVE OFFICE | 126.77 |
| LANT | N66833 | NAVSTA PANAMA CANAL ROOMAN PN | 15.10 | 1220 | ADMINISTRATION BUILDING | 61010 | ADMINISTRATIVE OFFICES | 126.77 |

| | | | | | | | | |
|-------|--------|-------------------------------|-------|------|-----------------------------|----------------------------------|---------|---|
| LANT | N66833 | NAVSTA PANAMA CANAL ROOMAN PN | 15.10 | 1220 | ADMINISTRATION BUILDING | 61010 ADMINISTRATIVE OFFICE | 126.77 | O |
| LANT | N66833 | NAVSTA PANAMA CANAL ROOMAN PN | 15.10 | 1220 | ADMINISTRATION BUILDING | 61010 ADMINISTRATIVE OFFICES | 126.77 | O |
| LANT | N66833 | NAVSTA PANAMA CANAL ROOMAN PN | 15.10 | 51 | ADMINISTRATION BUILDING | 61010 ADMINISTRATIVE OFFICE | 124.61 | O |
| LANT | N66833 | NAVSTA PANAMA CANAL ROOMAN PN | 15.10 | 51 | ADMINISTRATION BUILDING | 61010 ADMINISTRATIVE OFFICE | 124.61 | O |
| LANT | N66833 | NAVSTA PANAMA CANAL ROOMAN PN | 15.10 | 51 | ADMINISTRATION BUILDING | 61010 ADMINISTRATIVE OFFICE | 124.61 | O |
| LANT | N66833 | NAVSTA PANAMA CANAL ROOMAN PN | 15.10 | 51 | ADMINISTRATION BUILDING | 61010 ADMINISTRATIVE OFFICE | 124.61 | O |
| LANT | N70283 | NAVSECGRUACT GALETA IS PN | 22.83 | Q | BEQ/MESS HALL/QUARTER DECK | 72145 DINING FAC BUILT-IN/ATTD | 450.01 | D |
| LANT | N70283 | NAVSECGRUACT GALETA IS PN | 22.83 | 17 | ADMINISTRATION/BEQ | 61010 ADMINISTRATIVE OFFICE | 246.92 | O |
| LANT | N70283 | NAVSECGRUACT GALETA IS PN | 22.83 | 17 | ADMINISTRATION/BEQ | 61010 ADMINISTRATIVE OFFICE | 246.92 | O |
| LANT | N70283 | NAVSECGRUACT GALETA IS PN | 22.83 | 17 | ADMINISTRATION/BEQ | 61010 ADMINISTRATIVE OFFICE | 246.92 | O |
| NORTH | N00124 | NAVWARCOL NEWPORT RI | 24.53 | 29 | SIMS HALL | 17135 OPERATIONAL TRAINER FAC | 448.30 | T |
| NORTH | N00124 | NAVWARCOL NEWPORT RI | 24.53 | 3 | MAHAN HALL | 17110 ACADEMIC INSTRUCTION BLDG | 122.87 | T |
| NORTH | N00124 | NAVWARCOL NEWPORT RI | 24.53 | 1A | PRINGLE HALL | 17110 ACADEMIC INSTRUCTION BLDG | 159.91 | T |
| NORTH | N00124 | NAVWARCOL NEWPORT RI | 24.53 | 1 | LUCE HALL | 17110 ACADEMIC INSTRUCTION BLDG | 152.53 | T |
| NORTH | N00124 | NAVWARCOL NEWPORT RI | 24.53 | 991 | HEWITT HALL | 17110 ACADEMIC INSTRUCTION BLDG | 642.18 | T |
| NORTH | N00158 | NAS WILLOW GROVE PA | 16.62 | 626 | GALLEY | 72210 ENLISTED DINING FACILITY | 175.68 | D |
| NORTH | N00158 | NAS WILLOW GROVE PA | 16.62 | 140 | NAR ELECTRONIC | 17120 RESASUTC BLDG | 103.43 | T |
| NORTH | N00158 | NAS WILLOW GROVE PA | 16.62 | 176 | ARMY RESERVE TRAINING BLDG. | 17115 RESERVE TRAINING BUILDING | 177.26 | T |
| NORTH | N00383 | ASO PHILA PA | 17.60 | 3 | ADMINISTRATION 3 | 61010 ADMINISTRATIVE OFFICE | 716.44 | O |
| NORTH | N00383 | ASO PHILA PA | 17.60 | 4 | ADMINISTRATION | 61010 ADMINISTRATIVE OFFICE | 716.45 | O |
| NORTH | N00383 | ASO PHILA PA | 17.60 | 4 | ADMINISTRATION | 61010 ADMINISTRATIVE OFFICE | 716.45 | O |
| NORTH | N00383 | ASO PHILA PA | 17.60 | 4 | ADMINISTRATION | 61010 ADMINISTRATIVE OFFICE | 716.45 | O |
| NORTH | N00383 | ASO PHILA PA | 17.60 | 1 | ADMINISTRATION 1 | 61010 ADMINISTRATIVE OFFICE | 716.45 | O |
| NORTH | N00383 | ASO PHILA PA | 17.60 | 1 | ADMINISTRATION 1 | 61010 ADMINISTRATIVE OFFICE | 1039.38 | O |
| NORTH | N00383 | ASO PHILA PA | 17.60 | 36 | ADMINISTRATION 36 | 61010 ADMINISTRATIVE OFFICE | 1039.38 | O |
| NORTH | N61174 | NAVSTA BROOKLYN NY | 22.63 | 1A | FAMILY HOUSING | 71120 WHERRY HSG,ENLISTED | 101.29 | F |
| NORTH | N61174 | NAVSTA BROOKLYN NY | 22.63 | 2A | FAMILY HOUSING | 71120 WHERRY HSG,ENLISTED | 137.81 | F |
| NORTH | N61174 | NAVSTA BROOKLYN NY | 22.63 | 3A | FAMILY HOUSING | 71120 WHERRY HSG,ENLISTED | 138.07 | F |
| NORTH | N61174 | NAVSTA BROOKLYN NY | 22.63 | 4A | FAMILY HOUSING | 71120 WHERRY HSG,ENLISTED | 137.81 | F |
| NORTH | N61174 | NAVSTA BROOKLYN NY | 22.63 | 8A | FAMILY HOUSING | 71120 WHERRY HSG,ENLISTED | 113.51 | F |
| NORTH | N61174 | NAVSTA BROOKLYN NY | 22.63 | 10A | FAMILY HOUSING | 71120 WHERRY HSG,ENLISTED | 141.26 | F |
| NORTH | N61174 | NAVSTA BROOKLYN NY | 22.63 | 11A | FAMILY HOUSING | 71120 WHERRY HSG,ENLISTED | 127.61 | F |
| NORTH | N61174 | NAVSTA BROOKLYN NY | 22.63 | 12A | FAMILY HOUSING | 71120 WHERRY HSG,ENLISTED | 132.54 | F |
| NORTH | N61174 | NAVSTA BROOKLYN NY | 22.63 | 13A | FAMILY HOUSING | 71120 WHERRY HSG,ENLISTED | 103.88 | F |
| NORTH | N61174 | NAVSTA BROOKLYN NY | 22.63 | 1B | FAMILY HOUSING | 71120 WHERRY HSG,ENLISTED | 132.31 | F |
| NORTH | N61174 | NAVSTA BROOKLYN NY | 22.63 | 4B | FAMILY HOUSING | 71120 WHERRY HSG,ENLISTED | 127.38 | F |
| NORTH | N61174 | NAVSTA BROOKLYN NY | 22.63 | 6B | FAMILY HOUSING | 71120 WHERRY HSG,ENLISTED | 122.68 | F |
| NORTH | N61174 | NAVSTA BROOKLYN NY | 22.63 | 7B | FAMILY HOUSING | 71120 WHERRY HSG,ENLISTED | 146.64 | F |
| NORTH | N61174 | NAVSTA BROOKLYN NY | 22.63 | 9B | FAMILY HOUSING | 71120 WHERRY HSG,ENLISTED | 113.51 | F |
| NORTH | N61174 | NAVSTA BROOKLYN NY | 22.63 | 10B | FAMILY HOUSING | 71120 WHERRY HSG,ENLISTED | 113.28 | F |
| NORTH | N61174 | NAVSTA BROOKLYN NY | 22.63 | 11B | FAMILY HOUSING | 71120 WHERRY HSG,ENLISTED | 113.38 | F |
| NORTH | N61174 | NAVSTA BROOKLYN NY | 22.63 | 13B | FAMILY HOUSING | 71120 WHERRY HSG,ENLISTED | 125.98 | F |
| NORTH | N61174 | NAVSTA BROOKLYN NY | 22.63 | 15B | FAMILY HOUSING | 71120 WHERRY HSG,ENLISTED | 156.54 | F |
| NORTH | N61174 | NAVSTA BROOKLYN NY | 22.63 | 16B | FAMILY HOUSING | 71120 WHERRY HSG,ENLISTED | 113.64 | F |
| NORTH | N61174 | NAVSTA BROOKLYN NY | 22.63 | 17B | FAMILY HOUSING | 71120 WHERRY HSG,ENLISTED | 150.37 | F |
| NORTH | N61174 | NAVSTA BROOKLYN NY | 22.63 | 18B | FAMILY HOUSING | 71120 WHERRY HSG,ENLISTED | 134.75 | F |
| NORTH | N61174 | NAVSTA BROOKLYN NY | 22.63 | 895 | GEN COURT MARTIAL BLDG | 61010 ADMINISTRATIVE OFF (VAC) | 380.82 | O |
| NORTH | N61174 | NAVSTA BROOKLYN NY | 22.63 | 1 | MAIN LAB BUILDING | 61010 PERSUPPET | 895.51 | O |
| NORTH | N61174 | NAVSTA BROOKLYN NY | 22.63 | 2 | INDUSTRIAL BLDG | 61010 ADMINISTRATIVE OFFICE | 895.51 | O |
| NORTH | N61174 | NAVSTA BROOKLYN NY | 22.63 | 2 | INDUSTRIAL BLDG | 61010 ADMINISTRATIVE OFFICE | 432.71 | O |
| NORTH | N61174 | NAVSTA BROOKLYN NY | 22.63 | 1031 | UEPH | 72111 BEQ E1/E4 | 142.93 | B |
| NORTH | N61189 | NAVSTA PHILADELPHIA PA | 16.31 | 998 | HARTZELL DINING HALL | 72210 ENLISTED DINING FACILITY | 275.86 | D |
| NORTH | N61189 | NAVSTA PHILADELPHIA PA | 16.31 | 655 | APARTMENT BLDG A | 71143 FUND HSG,PRE 1950,0-6 | 173.57 | F |
| NORTH | N61189 | NAVSTA PHILADELPHIA PA | 16.31 | 657 | APARTMENT BLDG C | 71143 FUND HSG,PRE 1950,0-6 | 173.57 | F |
| NORTH | N61189 | NAVSTA PHILADELPHIA PA | 16.31 | 658 | APARTMENT BLDG D | 71143 FUND HSG,PRE 1950,0-6 | 173.57 | F |
| NORTH | N61189 | NAVSTA PHILADELPHIA PA | 16.31 | 656 | APARTMENT BLDG B | 71143 FUND HSG,PRE 1950,0-6 | 173.57 | F |
| NORTH | N61189 | NAVSTA PHILADELPHIA PA | 16.31 | 2101 | OFFICERS FAMILY HOUSING | 71131 FUND HSG,1950/69,W0,0-1/03 | 110.24 | F |
| NORTH | N61189 | NAVSTA PHILADELPHIA PA | 16.31 | 6106 | OFFICERS FAMILY HOUSING | 71131 FUND HSG,1950/69,W0,0-1/03 | 110.44 | F |
| NORTH | N61189 | NAVSTA PHILADELPHIA PA | 16.31 | 2103 | OFFICERS FAMILY HOUSING | 71131 FUND HSG,1950/69,W0,0-1/03 | 110.24 | F |

| | | | | | | | | | |
|-------|--------|----------------------------|-------|------|-----------------------------|-------|-------------------------------|---|---------|
| NORTH | N61189 | NAVSTA PHILADELPHIA PA | 16.31 | 2104 | OFFICERS FAMILY HOUSING | 71131 | FUND HSG, 1950/69, WO, 0-1/03 | F | 110.24 |
| NORTH | N61189 | NAVSTA PHILADELPHIA PA | 16.31 | 2105 | OFFICERS FAMILY HOUSING | 71131 | FUND HSG, 1950/69, WO, 0-1/03 | F | 110.24 |
| NORTH | N61189 | NAVSTA PHILADELPHIA PA | 16.31 | 2106 | OFFICERS FAMILY HOUSING | 71131 | FUND HSG, 1950/69, WO, 0-1/03 | F | 110.24 |
| NORTH | N61189 | NAVSTA PHILADELPHIA PA | 16.31 | 2108 | OFFICERS FAMILY HOUSING | 71131 | FUND HSG, 1950/69, WO, 0-1/03 | F | 110.24 |
| NORTH | N61189 | NAVSTA PHILADELPHIA PA | 16.31 | 2202 | ENLISTED MEN FAMILY HOUSING | 71130 | FUND HSG, 1950/69, ENLISTED | F | 110.24 |
| NORTH | N61189 | NAVSTA PHILADELPHIA PA | 16.31 | 2203 | ENLISTED MEN FAMILY HOUSING | 71130 | FUND HSG, 1950/69, ENLISTED | F | 110.24 |
| NORTH | N61189 | NAVSTA PHILADELPHIA PA | 16.31 | 2204 | ENLISTED MEN FAMILY HOUSING | 71130 | FUND HSG, 1950/69, ENLISTED | F | 110.24 |
| NORTH | N61189 | NAVSTA PHILADELPHIA PA | 16.31 | 6 | DISTRICT STAFF HEADQUARTERS | 61010 | COMNAVBASE | O | 157.96 |
| NORTH | N61189 | NAVSTA PHILADELPHIA PA | 16.31 | 600 | ADMINISTRATION BLDG | 61010 | ADMIN OFF (NAVREGCONTGEN) | O | 269.46 |
| NORTH | N61189 | NAVSTA PHILADELPHIA PA | 16.31 | 600 | ADMINISTRATION BLDG | 61010 | ADMIN OFF (PERSUPPET) | O | 269.46 |
| NORTH | N61189 | NAVSTA PHILADELPHIA PA | 16.31 | 600 | ADMINISTRATION BLDG | 61010 | ADMIN OFF (PERSUPPACT) | O | 269.46 |
| NORTH | N61189 | NAVSTA PHILADELPHIA PA | 16.31 | 75 | ADMINISTRATION OFFICES | 61010 | ADMIN OFF (4TH MARCOR) | O | 361.64 |
| NORTH | N61189 | NAVSTA PHILADELPHIA PA | 16.31 | 75 | ADMINISTRATION OFFICES | 61010 | ADMIN OFF (CCPO) | O | 361.64 |
| NORTH | N61189 | NAVSTA PHILADELPHIA PA | 16.31 | 75 | ADMINISTRATION OFFICES | 61010 | ADMIN OFF (DEF INVES SER) | O | 361.64 |
| NORTH | N61189 | NAVSTA PHILADELPHIA PA | 16.31 | 75 | ADMINISTRATION OFFICES | 61010 | ADMIN OFF (NAVSTA PHILA) | O | 361.64 |
| NORTH | N61189 | NAVSTA PHILADELPHIA PA | 16.31 | 75 | ADMINISTRATION OFFICES | 61010 | ADMIN OFF (OFFCPM MER) | O | 361.64 |
| NORTH | N61189 | NAVSTA PHILADELPHIA PA | 16.31 | 75 | ADMINISTRATION OFFICES | 61010 | ADMIN OFF (NAVIRSA) | O | 361.64 |
| NORTH | N61189 | NAVSTA PHILADELPHIA PA | 16.31 | 76 | ADMINISTRATION BLDG | 61010 | ADMIN OFF (SELECTIVE SER) | O | 361.64 |
| NORTH | N61189 | NAVSTA PHILADELPHIA PA | 16.31 | 76 | ADMINISTRATION BLDG | 61010 | PERA CRUDES | O | 789.04 |
| NORTH | N61189 | NAVSTA PHILADELPHIA PA | 16.31 | 76 | ADMINISTRATION BLDG | 61010 | ADMIN OFFICE MAVELEX | O | 789.04 |
| NORTH | N61189 | NAVSTA PHILADELPHIA PA | 16.31 | 76 | ADMINISTRATION BLDG | 61010 | ADMIN OFF (SEACENT/LANT) | O | 789.04 |
| NORTH | N61189 | NAVSTA PHILADELPHIA PA | 16.31 | 76 | ADMINISTRATION BLDG | 61010 | ADMIN OFFICE NAESU | O | 789.04 |
| NORTH | N61189 | NAVSTA PHILADELPHIA PA | 16.31 | 76 | ADMINISTRATION BLDG | 61010 | ADMIN OFFICE (NIS) | O | 789.04 |
| NORTH | N61189 | NAVSTA PHILADELPHIA PA | 16.31 | 77 | OFFICE-LABORATORY | 61010 | ADMIN OFF (PUBS & PRINT) | O | 511.42 |
| NORTH | N61189 | NAVSTA PHILADELPHIA PA | 16.31 | 77 | OFFICE-LABORATORY | 61010 | ADMINISTRATIVE OFFICE | O | 511.42 |
| NORTH | N61189 | NAVSTA PHILADELPHIA PA | 16.31 | 101 | BKS W/O MESS | 17115 | RESERVE TRAINING BUILDING | T | 280.91 |
| NORTH | N62269 | NAVAIRDEVGEN WARMINSTER PA | 15.93 | 3 | ADMINISTRATION BLDG | 61010 | ADMINISTRATIVE OFFICE | O | 357.44 |
| NORTH | N62269 | NAVAIRDEVGEN WARMINSTER PA | 15.93 | 3 | ADMINISTRATION BLDG | 61010 | ADMINISTRATIVE OFFICE | O | 357.44 |
| NORTH | N62661 | NETC NEWPORT RI | 28.95 | 197 | OGS DORMITORY-NIMITZ | 72114 | CLASS "A" STUDENTS | B | 192.49 |
| NORTH | N62661 | NETC NEWPORT RI | 28.95 | 197 | OGS DORMITORY-NIMITZ | 72114 | CLASS "A" STUDENTS | B | 192.49 |
| NORTH | N62661 | NETC NEWPORT RI | 28.95 | 291 | OGS DORMITORY-KING HALL CP | 72114 | CLASS "A" STUDENTS | B | 250.01 |
| NORTH | N62661 | NETC NEWPORT RI | 28.95 | 292 | OGS DORMITORY-KING HALL CP | 72114 | CLASS "A" STUDENTS | B | 349.38 |
| NORTH | N62661 | NETC NEWPORT RI | 28.95 | 355 | MESS HALL - NEY HALL | 72210 | ENLISTED DINING FACILITY | D | 358.87 |
| NORTH | N62661 | NETC NEWPORT RI | 28.95 | 1146 | MESS HALL CP | 72210 | ENLISTED DINING FACILITY | D | 124.76 |
| NORTH | N62661 | NETC NEWPORT RI | 28.95 | 1152 | SENIOR OFF QTRS 38DRM | 71132 | FUND HSG, 1950/69, 0-4, 0-5 | F | 124.76 |
| NORTH | N62661 | NETC NEWPORT RI | 28.95 | 1152 | SENIOR OFF QTRS 38DRM | 71132 | FUND HSG, 1950/69, 0-4, 0-5 | F | 124.76 |
| NORTH | N62661 | NETC NEWPORT RI | 28.95 | K61 | CLASSROOMS/OFFICES CP | 61010 | ADMIN: PW/ADMIN/PSA/PSD | O | 119.95 |
| NORTH | N62661 | NETC NEWPORT RI | 28.95 | 1 | ADMIN BUILDING | 61010 | ADMIN PW/SUPPLY/ROICC/ETC | O | 154.08 |
| NORTH | N62661 | NETC NEWPORT RI | 28.95 | 6 | ADMIN. OFFICES CC | 61010 | ADMINISTRATIVE OFFICE | O | 111.75 |
| NORTH | N62661 | NETC NEWPORT RI | 28.95 | 5 | RECEIVING/DEL-ADM BLDG CC | 61010 | ADMINISTRATIVE OFFICE | O | 120.06 |
| NORTH | N62661 | NETC NEWPORT RI | 28.95 | 42 | COLD STORAGE CC | 61010 | ADMINISTRATIVE OFFICE | O | 193.97 |
| NORTH | N62661 | NETC NEWPORT RI | 28.95 | 121 | SHWIMMING POOL | 74053 | INDOOR SWIMMING POOL | P | 220.78 |
| NORTH | N62661 | NETC NEWPORT RI | 28.95 | 302 | GYMNASIUM | 17140 | DRILL HALL | T | 107.51 |
| NORTH | N62661 | NETC NEWPORT RI | 28.95 | 1801 | OGC DRILL HALL | 17140 | DRILL HALL | T | 107.51 |
| NORTH | N62661 | NETC NEWPORT RI | 28.95 | 440 | TECH TRNG BLDG-PERRY HALL | 17110 | ACADEMIC INSTRUCTION BLDG | T | 537.74 |
| NORTH | N62661 | NETC NEWPORT RI | 28.95 | 440 | TECH TRNG BLDG-PERRY HALL | 17110 | ACADEMIC INSTRUCTION BLDG | T | 537.74 |
| NORTH | N62661 | NETC NEWPORT RI | 28.95 | 1112 | OFFICE-CLASSROOMS CP | 17110 | ACADEMIC INSTRUCTION BLDG | T | 117.14 |
| NORTH | N62661 | NETC NEWPORT RI | 28.95 | 1112 | OFFICE-CLASSROOMS CP | 17110 | ACADEMIC INSTRUCTION BLDG | T | 117.14 |
| NORTH | N62661 | NETC NEWPORT RI | 28.95 | 370 | OPERATIONS TRAIN BLDG CP | 17120 | APPLIED INSTRUCTION BLDG | T | 185.51 |
| NORTH | N62661 | NETC NEWPORT RI | 28.95 | 114 | CHAPLAIN SCH/LIBRARY | 17110 | ACADEMIC INSTR. (CHAPLAIN) | T | 108.29 |
| NORTH | N62661 | NETC NEWPORT RI | 28.95 | 360 | JUSTICE SCHOOL | 17120 | ACADEMIC INSTR BLDG | T | 178.24 |
| NORTH | N62661 | NETC NEWPORT RI | 28.95 | A63 | WAREHOUSE-CC | 17120 | APPLIED INSTRUCTION BLDG | T | 125.96 |
| NORTH | N62661 | NETC NEWPORT RI | 28.95 | 446 | APPL INST BLDG CHI SWOS | 17120 | APPLIED INSTRUCTION BLDG | T | 206.29 |
| NORTH | N62661 | NETC NEWPORT RI | 28.95 | 678 | ENLISTED MESS (OPEN) | 61010 | ADMINISTRATIVE OFFICE | O | 102.14 |
| NORTH | N65540 | NAVSSSES PHILADELPHIA PA | 15.38 | 678 | COMDS QTRS-OFFICERS HOUSING | 71142 | FUND HSG, PRE 1950, 0-4, 0-5 | F | 104.89 |
| NORTH | N66604 | NUSC NEWPORT RI | 23.82 | 27 | ADMINISTRATION BLDG CC | 61010 | NRCC ADMIN. | O | 150.18 |
| NORTH | N66604 | NUSC NEWPORT RI | 23.82 | 11 | ADMINISTRATION BLDG CC | 61010 | CONSTR. ADMIN. | O | 150.18 |
| NORTH | N66604 | NUSC NEWPORT RI | 23.82 | 11 | ADMINISTRATION BLDG CC | 61010 | ADMIN OFFICE (SUP SHIP) | O | 150.18 |
| NORTH | N66604 | NUSC NEWPORT RI | 23.82 | 11 | ADMINISTRATION BLDG CC | 61010 | ADMIN OFFICE (SUP SHIP) | O | 150.18 |
| NORTH | N66604 | NUSC NEWPORT RI | 23.77 | 1 | MAIN HOSPITAL BLDG 1 | 51010 | HOSPITAL | H | 1853.00 |
| NORTH | N68101 | NAVHOSP PHILADELPHIA PA | 20.14 | 30 | HARRIED OFFICERS QUARTERS | 71142 | FUND HSG, PRE 1950, U-4, U-3 | F | 140.70 |
| NORTH | N68101 | NAVHOSP PHILADELPHIA PA | 20.14 | 12 | HOSPITAL | 51010 | VACANT | H | 195.46 |

| | | | | | | | | | |
|-------|--------|--------------------------|-------|--------|------------------------------|-------|---------------------------|---|---------|
| NORTH | N68101 | NAVHOSP PHILADELPHIA PA | 20.14 | 45 | WARD I-6 DEPENDENTS SERVICE | 51010 | SAFETY & OCC. HEALTH | H | 102.59 |
| NORTH | N68101 | NAVHOSP PHILADELPHIA PA | 20.14 | 52 | ACOUSTIC CLINIC | 51010 | VACANT | H | 108.46 |
| NORTH | N68101 | NAVHOSP PHILADELPHIA PA | 20.14 | 1 | MAIN HOSPITAL | 51010 | HOSPITAL | H | 3584.24 |
| NORTH | N68335 | NAVARENGCEN LAKEHURST NJ | 20.14 | 46 | DEPENDENTS CLINIC-ADMIN | 61010 | ADMINISTRATIVE OFFICE | O | 105.89 |
| NORTH | N68335 | NAVARENGCEN LAKEHURST NJ | 15.41 | 484 | SUBSISTENCE BUILDING | 72210 | ENLISTED DINING FACILITY | D | 207.62 |
| NORTH | N68335 | NAVARENGCEN LAKEHURST NJ | 15.41 | T | MARRIED OFFICERS QTRS-APTS | 71141 | END HSG,PRE 1950,W,O-1/03 | F | 102.73 |
| NORTH | N68335 | NAVARENGCEN LAKEHURST NJ | 15.41 | 120 | ADMINISTRATION | 61010 | PSD ADMIN OFFICE | O | 402.15 |
| NORTH | N68335 | NAVARENGCEN LAKEHURST NJ | 15.41 | 120 | ADMINISTRATION | 61010 | ADMIN OFF (12240 VAC) | O | 402.15 |
| NORTH | N68335 | NAVARENGCEN LAKEHURST NJ | 15.41 | 120 | ADMINISTRATION | 61010 | NIS ADMIN OFFICE | O | 402.15 |
| NORTH | N68335 | NAVARENGCEN LAKEHURST NJ | 15.41 | 129 | GEN SUPPLY OFFICE/STOREHOUSE | 61010 | SUPPLY/CONTR. ADMIN. | O | 222.50 |
| NORTH | N68335 | NAVARENGCEN LAKEHURST NJ | 15.41 | 129 | GEN SUPPLY OFFICE/STOREHOUSE | 61010 | BRASO ADMIN | O | 222.50 |
| NORTH | N68335 | NAVARENGCEN LAKEHURST NJ | 15.41 | 1 | HANGAR #1 | 17135 | OPERATIONAL TRAINER FAC | T | 1202.64 |
| NORTH | N68335 | NAVARENGCEN LAKEHURST NJ | 15.41 | 123 | MATTC PR TRNG/PW/SUPPLY STOR | 17120 | ENLISTED INSTRUCTION BLDG | T | 244.52 |
| NORTH | N68335 | NAVARENGCEN LAKEHURST NJ | 15.41 | 150 | MATTC ADMIN | 17120 | APPLIED INSTRUCTION BLDG | T | 124.01 |
| WEST | M00243 | MCRD SAN DIEGO CA | 15.57 | 554 | RECRUIT BARRACKS | 72115 | RECRUIT BARRACKS | B | 158.07 |
| WEST | M00243 | MCRD SAN DIEGO CA | 15.57 | 555 | RECRUIT BARRACKS | 72115 | RECRUIT BARRACKS | B | 158.07 |
| WEST | M00243 | MCRD SAN DIEGO CA | 15.57 | 570 | RECRUIT BARRACKS | 72115 | RECRUIT BARRACKS | B | 158.07 |
| WEST | M00243 | MCRD SAN DIEGO CA | 15.57 | 584 | RECRUIT BKKS | 72115 | RECRUIT BARRACKS | B | 153.44 |
| WEST | M00243 | MCRD SAN DIEGO CA | 15.57 | 585 | RECRUIT BKKS | 72115 | RECRUIT BARRACKS | B | 153.44 |
| WEST | M00243 | MCRD SAN DIEGO CA | 15.57 | 625 | BEQ | 72111 | BEQ E1/E4 | B | 179.85 |
| WEST | M00243 | MCRD SAN DIEGO CA | 15.57 | 619 | BEQ | 72113 | BEQ E7/E9 (MC E6/E9) | B | 189.59 |
| WEST | M00243 | MCRD SAN DIEGO CA | 15.57 | 569 | RECRUIT MESSHALL | 72210 | ENLISTED DINING FACILITY | D | 549.99 |
| WEST | M00243 | MCRD SAN DIEGO CA | 15.57 | 620 | DUNCAN MESSHALL | 72210 | ENLISTED DINING FACILITY | D | 213.26 |
| WEST | M00243 | MCRD SAN DIEGO CA | 15.57 | 3 | HQS 2ND/3RD RT BNS | 61010 | ADMINISTRATIVE OFFICE | O | 111.66 |
| WEST | M00243 | MCRD SAN DIEGO CA | 15.57 | 12 | LAW CENTER | 61010 | ADMINISTRATIVE OFFICE | O | 109.26 |
| WEST | M00243 | MCRD SAN DIEGO CA | 15.57 | 26 | MUSEUM/FAMILY SVC | 61010 | ADMINISTRATIVE OFFICE | O | 143.46 |
| WEST | M00243 | MCRD SAN DIEGO CA | 15.57 | 28 | SPT BN AND RTR HQ | 61010 | ADMINISTRATIVE OFFICE | O | 138.39 |
| WEST | M00243 | MCRD SAN DIEGO CA | 15.57 | 31 | PENDELTON HALL | 61010 | ADMINISTRATIVE OFFICE | O | 187.25 |
| WEST | M00243 | MCRD SAN DIEGO CA | 15.57 | 27 | RCRT SCHOOL | 17110 | ACADEMIC INSTRUCTION BLDG | T | 274.95 |
| WEST | M00243 | MCRD SAN DIEGO CA | 15.57 | 626 | RECRUIT TRAINING FACILITY | 17120 | RECRUIT TRG FACILITY | T | 242.92 |
| WEST | M00681 | MCB CAMP PENDLETON CA | 16.24 | 31613 | UEPH | 72115 | RECRUIT BARRACKS | B | 105.06 |
| WEST | M00681 | MCB CAMP PENDLETON CA | 16.24 | 31612 | UEPH | 72115 | RECRUIT BARRACKS | B | 105.06 |
| WEST | M00681 | MCB CAMP PENDLETON CA | 16.24 | 31603 | UEPH | 72115 | RECRUIT BARRACKS | B | 105.06 |
| WEST | M00681 | MCB CAMP PENDLETON CA | 16.24 | 210440 | 80Q W/CLOSED MESS | 72411 | 80Q,W-1/O-2 | B | 128.02 |
| WEST | M00681 | MCB CAMP PENDLETON CA | 16.24 | 520440 | UEPH/CO ADMIN | 72115 | RECRUIT BARRACKS | B | 126.13 |
| WEST | M00681 | MCB CAMP PENDLETON CA | 16.24 | 520422 | UEPH/CO ADMIN | 72115 | RECRUIT BARRACKS | B | 166.55 |
| WEST | M00681 | MCB CAMP PENDLETON CA | 16.24 | 520420 | UEPH/CO ADMIN | 72115 | RECRUIT BARRACKS | B | 198.58 |
| WEST | M00681 | MCB CAMP PENDLETON CA | 16.24 | 33605 | UEPH/CO ADMIN | 72111 | BEQ E1/E4 | B | 116.20 |
| WEST | M00681 | MCB CAMP PENDLETON CA | 16.24 | 1283 | DINING FACILITY | 72210 | ENLISTED DINING FACILITY | D | 176.71 |
| WEST | M00681 | MCB CAMP PENDLETON CA | 16.24 | 1685 | DINING FACILITY | 72210 | ENLISTED DINING FACILITY | D | 179.57 |
| WEST | M00681 | MCB CAMP PENDLETON CA | 16.24 | 22186 | MESS-GALLEY | 72210 | ENLISTED DINING FACILITY | D | 301.06 |
| WEST | M00681 | MCB CAMP PENDLETON CA | 16.24 | 2581 | DINING FACILITY | 72210 | ENLISTED DINING FACILITY | D | 164.08 |
| WEST | M00681 | MCB CAMP PENDLETON CA | 16.24 | 33302 | DINING FACILITY | 72210 | ENLISTED DINING FACILITY | D | 286.90 |
| WEST | M00681 | MCB CAMP PENDLETON CA | 16.24 | 33502 | DINING FACILITY | 72210 | ENLISTED DINING FACILITY | D | 286.90 |
| WEST | M00681 | MCB CAMP PENDLETON CA | 16.24 | 43302 | DINING FACILITY | 72210 | ENLISTED DINING FACILITY | D | 286.80 |
| WEST | M00681 | MCB CAMP PENDLETON CA | 16.24 | 43402 | DINING FACILITY | 72210 | ENLISTED DINING FACILITY | D | 286.80 |
| WEST | M00681 | MCB CAMP PENDLETON CA | 16.24 | 53402 | DINING FACILITY | 72210 | ENLISTED DINING FACILITY | D | 286.80 |
| WEST | M00681 | MCB CAMP PENDLETON CA | 16.24 | 53502 | DINING FACILITY | 72210 | ENLISTED DINING FACILITY | D | 286.83 |
| WEST | M00681 | MCB CAMP PENDLETON CA | 16.24 | 62402 | DINING FACILITY | 72210 | ENLISTED DINING FACILITY | D | 286.83 |
| WEST | M00681 | MCB CAMP PENDLETON CA | 16.24 | 62502 | DINING FACILITY | 72210 | ENLISTED DINING FACILITY | D | 286.78 |
| WEST | M00681 | MCB CAMP PENDLETON CA | 16.24 | 64322 | MESS-GALLEY/ADMIN | 72210 | ENLISTED DINING FACILITY | D | 186.68 |
| WEST | M00681 | MCB CAMP PENDLETON CA | 16.24 | 210702 | DINING FACILITY | 72210 | ENLISTED DINING FACILITY | D | 236.29 |
| WEST | M00681 | MCB CAMP PENDLETON CA | 16.24 | 210802 | DINING FACILITY | 72210 | ENLISTED DINING FACILITY | D | 236.29 |
| WEST | M00681 | MCB CAMP PENDLETON CA | 16.24 | 31611 | DINING FACILITY | 72210 | ENLISTED DINING FACILITY | D | 331.57 |
| WEST | M00681 | MCB CAMP PENDLETON CA | 16.24 | 41358 | MESS-HALL | 72210 | ENLISTED DINING FACILITY | D | 121.15 |
| WEST | M00681 | MCB CAMP PENDLETON CA | 16.24 | 520430 | DINING FAC/HEAT PLT BLDG | 72210 | ENLISTED DINING FACILITY | D | 676.01 |
| WEST | M00681 | MCB CAMP PENDLETON CA | 16.24 | 13100 | DINING FACILITY | 72210 | ENLISTED DINING FACILITY | D | 157.98 |
| WEST | M00681 | MCB CAMP PENDLETON CA | 16.24 | 14013 | DINING FACILITY | 72210 | ENLISTED DINING FACILITY | D | 163.55 |
| WEST | M00681 | MCB CAMP PENDLETON CA | 16.24 | 4403 | ENLISTED DINING FACILITY | 72210 | ENLISTED DINING FACILITY | D | 144.09 |
| WEST | M00681 | MCB CAMP PENDLETON CA | 16.24 | P-3006 | MESSHALL | 72210 | ENL DINING FAC(DET) | D | 280.33 |

| | | | | | | | | | |
|------|--------|----------------------------|-------|--------|------------------------------|-------|---------------------------|---------|---|
| WEST | H00681 | MCB CAMP PENDLETON CA | 16.24 | 1160 | BASE HEADQUARTERS BLDG | 61010 | ADMINISTRATIVE OFFICE | 208.42 | O |
| WEST | H00681 | MCB CAMP PENDLETON CA | 16.24 | 210730 | ACADEMIC INSTRUCTION | 17110 | ACADEMIC INSTRUCTION BLDG | 104.03 | T |
| WEST | H00681 | MCB CAMP PENDLETON CA | 16.24 | 210567 | OPER TRNG | 17135 | OPERATIONAL TRAINER FAC | 115.43 | T |
| WEST | H60050 | MCAS EL TORO SANTA ANA CA | 20.99 | 77 | COOK SCH/EXCH BLDG | 72210 | FOOD SERVICES ADMIN | 216.23 | D |
| WEST | H60050 | MCAS EL TORO SANTA ANA CA | 20.99 | 322 | MESS HALL/ENLISTED | 72210 | ENLISTED DINING FAC #3 | 131.34 | D |
| WEST | H60050 | MCAS EL TORO SANTA ANA CA | 20.99 | 364 | MESSHALL | 72210 | ENLISTED MESS HALL #2 | 503.22 | D |
| WEST | H60050 | MCAS EL TORO SANTA ANA CA | 20.99 | 58 | JOINT RECEPTION CENTER | 61010 | JRC/HSG/HSHLD GOODS | 111.82 | O |
| WEST | H60050 | MCAS EL TORO SANTA ANA CA | 20.99 | 75 | SERVICES BLDG | 61010 | AC/S SERVICES/CLUBS ADMIN | 159.63 | O |
| WEST | H60050 | MCAS EL TORO SANTA ANA CA | 20.99 | 321 | ADMIN-SHIPPING-REC | 61010 | SUPPLY/ACCTG OFFICE | 256.80 | O |
| WEST | H60050 | MCAS EL TORO SANTA ANA CA | 20.99 | 324 | TRAINING BLDG | 17120 | NAHTRADETS APPLIED INSTR | 177.99 | T |
| WEST | H60050 | MCAS EL TORO SANTA ANA CA | 20.99 | 443 | TRAINING BUILDING | 17110 | ACADEMIC INSTRUCTION BLDG | 121.40 | T |
| WEST | H60050 | MCAS EL TORO SANTA ANA CA | 20.99 | 2394 | OPERATIONAL TRAINER FACILITY | 17135 | OPERATIONAL TRAINER FAC | 138.63 | T |
| WEST | H62204 | MCLB BARSTOW CA | 22.00 | 175 | MESS HALL/LIBRARY | 72210 | ENLISTED DINING FACILITY | 266.55 | D |
| WEST | H62204 | MCLB BARSTOW CA | 22.00 | 15 | HOOTRS-MCLBB | 61010 | ADMINISTRATIVE OFFICE | 101.00 | O |
| WEST | H62204 | MCLB BARSTOW CA | 22.00 | 30 | HOBV/ADMINISTRATION BLDG | 61010 | ADMINISTRATIVE OFFICE | 125.79 | O |
| WEST | H67399 | MCAGCC TWENTYNINE PALMS CA | 20.09 | 1400 | MESS HALL | 72210 | ENLISTED DINING FACILITY | 231.44 | D |
| WEST | H67399 | MCAGCC TWENTYNINE PALMS CA | 20.09 | 1420 | MESS-GALLEY | 72210 | ENLISTED DINING FACILITY | 231.44 | D |
| WEST | H67399 | MCAGCC TWENTYNINE PALMS CA | 20.09 | 1610 | MESS-GALLEY | 72210 | ENLISTED DINING FACILITY | 231.44 | D |
| WEST | H67399 | MCAGCC TWENTYNINE PALMS CA | 20.09 | 1630 | DINING HALL | 72210 | ENLISTED DINING FACILITY | 231.44 | D |
| WEST | H67399 | MCAGCC TWENTYNINE PALMS CA | 20.09 | 1650 | ENLISTED DINING FACILITY | 72210 | ENLISTED DINING FACILITY | 238.07 | D |
| WEST | H67399 | MCAGCC TWENTYNINE PALMS CA | 20.09 | 1551 | STATION HOSPITAL | 51010 | HOSPITAL | 465.01 | H |
| WEST | H67399 | MCAGCC TWENTYNINE PALMS CA | 20.09 | 1859 | MARINE TACT DATA SYS | 17120 | APPLIED INSTRUCTION BLDG | 113.12 | T |
| WEST | H67399 | MCAGCC TWENTYNINE PALMS CA | 20.09 | 1737 | ACADEMIC INST BLDG | 17110 | ACADEMIC INSTRUCTION BLDG | 117.83 | T |
| WEST | H67399 | MCAGCC TWENTYNINE PALMS CA | 20.09 | 1738 | APPLIED INST BLDG | 17120 | APPLIED INSTRUCTION BLDG | 117.83 | T |
| WEST | H67399 | MCAGCC TWENTYNINE PALMS CA | 20.09 | 1747 | APPLIED INST BLDG | 17120 | APPLIED INSTRUCTION BLDG | 117.83 | T |
| WEST | H67399 | MCAGCC TWENTYNINE PALMS CA | 20.09 | 1748 | APPLIED INST BLDG | 17120 | APPLIED INSTRUCTION BLDG | 117.83 | T |
| WEST | H67399 | MCAGCC TWENTYNINE PALMS CA | 20.09 | 1757 | ACADEMIC INST BLDG | 17110 | ACADEMIC INSTRUCTION BLDG | 117.83 | T |
| WEST | H67399 | MCAGCC TWENTYNINE PALMS CA | 20.09 | 1758 | APPLIED INST BLDG | 17120 | APPLIED INSTRUCTION BLDG | 117.83 | T |
| WEST | H67399 | MCAGCC TWENTYNINE PALMS CA | 20.09 | 1761 | ACADEMIC INSTRUCTION BLDG A | 17110 | ACADEMIC INSTRUCTION BLDG | 117.83 | T |
| WEST | H00236 | NAS ALAMEDA CA | 15.98 | 2 | ENLISTED MENS BARRACKS | 72113 | UEPH 53, 1705F ? | 294.71 | B |
| WEST | H00236 | NAS ALAMEDA CA | 15.98 | 4 | E M BARRACKS | 72111 | BEQ E1/E4 | 314.55 | B |
| WEST | H00236 | NAS ALAMEDA CA | 15.98 | 17 | BACHELORS OFFICERS QUARTERS | 72412 | FIRE PROTECT THIS BLDG | 198.08 | B |
| WEST | H00236 | NAS ALAMEDA CA | 15.98 | 3 | MESS HALL-GALLEY | 72145 | DINING FAC BUILT-IN/ATTD | 682.11 | D |
| WEST | H00236 | NAS ALAMEDA CA | 15.98 | 1 | ADMINISTRATION BUILDING | 61010 | ADMINISTRATIVE OFFICE | 178.80 | O |
| WEST | H00236 | NAS ALAMEDA CA | 15.98 | 1 | ADMINISTRATION BUILDING | 61010 | ADMINISTRATIVE OFFICE | 178.80 | O |
| WEST | H00236 | NAS ALAMEDA CA | 15.98 | 1 | ADMINISTRATION BUILDING | 61010 | ADMINISTRATIVE OFFICE | 178.80 | O |
| WEST | H00236 | NAS ALAMEDA CA | 15.98 | 101 | TRAINING BUILDING | 61010 | ADMINISTRATIVE OFFICE | 257.10 | O |
| WEST | H00236 | NAS ALAMEDA CA | 15.98 | 101 | TRAINING BUILDING | 61010 | ADMINISTRATIVE OFFICE | 257.10 | O |
| WEST | H00236 | NAS ALAMEDA CA | 15.98 | 101 | TRAINING BUILDING | 61010 | ADMINISTRATIVE OFFICE | 257.10 | O |
| WEST | H00236 | NAS ALAMEDA CA | 15.98 | 101 | TRAINING BUILDING | 61010 | ADMINISTRATIVE OFFICE | 257.10 | O |
| WEST | H00236 | NAS ALAMEDA CA | 15.98 | 162 | ENG ACCESSOR OVERHAUL SHOP | 61010 | ADMIN | 390.97 | O |
| WEST | H00236 | NAS ALAMEDA CA | 15.98 | 162 | ENG ACCESSOR OVERHAUL SHOP | 61010 | ADMINISTRATIVE OFFICE | 390.97 | O |
| WEST | H00236 | NAS ALAMEDA CA | 15.98 | 76 | E.M. SWIMMING POOL | 74053 | INDOOR SWIMMING POOL | 412.27 | P |
| WEST | H00247 | NTC SAN DIEGO CA | 18.76 | 82 | B O WITH MESS | 72412 | 800,0-3 AND ABOVE | 100.15 | B |
| WEST | H00247 | NTC SAN DIEGO CA | 18.76 | 482 | RECRUIT BARRACKS | 72115 | RECRUIT BARRACKS | 124.47 | B |
| WEST | H00247 | NTC SAN DIEGO CA | 18.76 | 481 | RECRUIT BARRACKS | 72115 | RECRUIT BARRACKS | 124.47 | B |
| WEST | H00247 | NTC SAN DIEGO CA | 18.76 | 88 | RECRUIT BARRACKS | 72115 | RECRUIT BARRACKS | 124.47 | B |
| WEST | H00247 | NTC SAN DIEGO CA | 18.76 | 89 | RECRUIT BARRACKS | 72115 | RECRUIT BARRACKS | 124.47 | B |
| WEST | H00247 | NTC SAN DIEGO CA | 18.76 | 92 | RECRUIT BARRACKS | 72114 | CLASS A STUDENT BARRACKS | 124.47 | B |
| WEST | H00247 | NTC SAN DIEGO CA | 18.76 | 93 | RECRUIT BARRACKS | 72114 | CLASS A STUDENT BARRACKS | 124.47 | B |
| WEST | H00247 | NTC SAN DIEGO CA | 18.76 | 64 | MESS HALL NO 8 | 72210 | ENLISTED DINING FACILITY | 664.64 | D |
| WEST | H00247 | NTC SAN DIEGO CA | 18.76 | 55 | ENLISTED DINING FACILITY | 72210 | ENLISTED DINING FACILITY | 1102.24 | D |
| WEST | H00247 | NTC SAN DIEGO CA | 18.76 | 87 | MESSHALL | 72210 | ENLISTED DINING FACILITY | 157.67 | O |
| WEST | H00247 | NTC SAN DIEGO CA | 18.76 | 328 | RTC HEADQUARTERS BLDG | 61010 | ADMINISTRATIVE OFFICE | 102.68 | T |
| WEST | H00247 | NTC SAN DIEGO CA | 18.76 | 175 | ACADEMIC INST BLDG | 17120 | APPLIED INSTRUCTION BLDG | 150.83 | T |
| WEST | H00247 | NTC SAN DIEGO CA | 18.76 | 49 | SCHOOL TRADE/MACH RPR/MTLLRG | 17120 | APPLIED INSTRUCTION BLDG | 150.83 | T |
| WEST | H00247 | NTC SAN DIEGO CA | 18.76 | 83 | COMMUNICATIONS SCHOOL | 17120 | APPLIED INSTRUCTION BLDG | 382.49 | T |
| WEST | H00247 | NTC SAN DIEGO CA | 18.76 | 485 | RECRUIT SCHOOL | 17110 | ACADEMIC INSTRUCTION BLDG | 227.75 | T |

| WEST | 00247 | NTC | SAN DIEGO CA | 18.76 | 94 | TECHNICAL TRAINING BLDG | 17120 | APPLIED INSTRUCTION BLDG | 961.26 | T |
|------|--------|---------------------|--------------|-------|-----|------------------------------|-------|---------------------------|----------|---|
| WEST | N00259 | NAVHOSP | SAN DIEGO CA | 16.13 | 28 | ENLISTED MEN BARRACKS | 72111 | 8EO E1/E4 | 271.46 | B |
| WEST | N00259 | NAVHOSP | SAN DIEGO CA | 16.13 | 15 | HOSPITAL-DEPENDENTS WARD | 51010 | HOSPITAL | 406.05 | H |
| WEST | N00259 | NAVHOSP | SAN DIEGO CA | 16.13 | 22 | OPD CLINIC | 51010 | HOSPITAL | 267.33 | H |
| WEST | N00259 | NAVHOSP | SAN DIEGO CA | 16.13 | 38 | HOSPITAL-DEPENDENTS | 51010 | HOSPITAL | 372.89 | H |
| WEST | N00259 | NAVHOSP | SAN DIEGO CA | 16.13 | 26 | HOSPITAL - SURGICAL | 51010 | INPATIENT HOSPITAL | 4712.32 | H |
| WEST | N00259 | NAVHOSP | SAN DIEGO CA | 16.13 | 11 | MAIN HOSPITAL COMPLEX | 51010 | HOSPITAL | 10594.41 | H |
| WEST | N00259 | NAVHOSP | SAN DIEGO CA | 16.13 | 1 | OPS MGMT | 61010 | ADMINISTRATIVE OFFICE | 145.14 | O |
| WEST | N00259 | NAVHOSP | SAN DIEGO CA | 16.13 | 9 | ADMIN /MEDICAL HOLD | 61010 | ADMINISTRATIVE OFFICE | 111.88 | O |
| WEST | N00259 | NAVHOSP | SAN DIEGO CA | 16.13 | 8 | TNSHS BLDG B | 17120 | APPLIED INSTRUCTION BLDG | 116.88 | O |
| WEST | N00259 | NAVHOSP | SAN DIEGO CA | 16.13 | 14A | DENTAL CLINIC | 51010 | DENTAL CLINIC | 266.57 | T |
| WEST | N00619 | NAVHOSP | OAKLAND CA | 15.64 | 67 | PROSTHETICS LAB | 51010 | HOSPITAL/PROSTHETICS LAB | 375.71 | T |
| WEST | N00619 | NAVHOSP | OAKLAND CA | 15.64 | 102 | HOSPITAL | 51010 | HOSPITAL | 167.76 | H |
| WEST | N00619 | NAVHOSP | OAKLAND CA | 15.64 | 500 | INDOOR SWIMMING POOL | 74053 | INDOOR SWIMMING POOL | 5770.93 | H |
| WEST | N00619 | NAVHOSP | OAKLAND CA | 15.64 | 138 | OPERATIONAL TRAINER FACILITY | 17135 | OPERATIONAL TRAINER FAC | 152.67 | P |
| WEST | N61665 | FLECOMBATRACENPAC | SAN DIEGO CA | 17.59 | 24 | ACADEMIC INSTRUCTION BLDG | 17120 | APPLIED INSTRUCTION BLDG | 616.32 | T |
| WEST | N61665 | FLECOMBATRACENPAC | SAN DIEGO CA | 17.59 | 50 | ACADEMIC INSTRUCTION BLDG | 17120 | APPLIED INSTRUCTION BLDG | 213.19 | T |
| WEST | N62271 | NAVPGSCOL | MONTEREY CA | 17.59 | 56 | ADMIN BLDG | 61010 | ADMINISTRATIVE OFFICE | 140.11 | T |
| WEST | N62271 | NAVPGSCOL | MONTEREY CA | 17.74 | 221 | ADMIN BLDG | 61010 | ADMINISTRATIVE OFFICE | 249.52 | O |
| WEST | N62271 | NAVPGSCOL | MONTEREY CA | 17.74 | 221 | HERMAN HALL BOQ ADMIN OFFICE | 61010 | ADMINISTRATIVE OFFICE | 249.52 | O |
| WEST | N62271 | NAVPGSCOL | MONTEREY CA | 17.74 | 220 | ELEC ENGINEERING LABORATORY | 17120 | APPLIED INSTRUCTION BLDG | 716.06 | O |
| WEST | N62271 | NAVPGSCOL | MONTEREY CA | 17.74 | 233 | ACAD/GEN INST BLDG, SPANAGEL | 17120 | APPLIED INSTRUCTION BLDG | 135.25 | T |
| WEST | N62271 | NAVPGSCOL | MONTEREY CA | 17.74 | 232 | AERONAUTICAL MECH ENGR LABS | 17120 | APPLIED INSTRUCTION BLDG | 815.50 | T |
| WEST | N62271 | NAVPGSCOL | MONTEREY CA | 17.74 | 234 | ROOT HALL | 17120 | APPLIED INSTRUCTION BLDG | 313.26 | T |
| WEST | N62271 | NAVPGSCOL | MONTEREY CA | 17.74 | 235 | INGERSOLL HALL | 17110 | ACADEMIC INSTRUCTION BLDG | 294.45 | T |
| WEST | N62271 | NAVPGSCOL | MONTEREY CA | 17.74 | 330 | DUDLEY KNOX LIBRARY | 17110 | ACA INST (LIBRARY) | 308.46 | T |
| WEST | N62474 | WESTNAVFACENGCOM | SAN BRUNO CA | 17.74 | 339 | ADMINISTRATION BUILDING | 61010 | ADMINISTRATIVE OFFICE | 197.68 | T |
| WEST | N62474 | WESTNAVFACENGCOM | SAN BRUNO CA | 17.28 | 127 | ADMINISTRATION BUILDING | 61010 | ADMINISTRATIVE OFFICE | 201.95 | O |
| WEST | N62474 | WESTNAVFACENGCOM | SAN BRUNO CA | 17.28 | 127 | ADMINISTRATION BUILDING | 61010 | ADMINISTRATIVE OFFICE | 201.95 | O |
| WEST | N62474 | WESTNAVFACENGCOM | SAN BRUNO CA | 17.28 | 127 | ADMINISTRATION BUILDING | 61010 | ADMINISTRATIVE OFFICE | 201.95 | O |
| WEST | N62583 | CBC PORT HUENEME CA | | 19.39 | 61 | ENLISTED MENS DINING/GALLEY | 72210 | ENLISTED DINING FACILITY | 506.42 | D |
| WEST | N62583 | CBC PORT HUENEME CA | | 19.39 | 40 | CIVIL ENGR SUPPORT OFFICE | 61010 | ADMINISTRATIVE OFFICE | 111.11 | O |
| WEST | N62583 | CBC PORT HUENEME CA | | 19.39 | 14 | CBC ADMINISTRATION BLDG | 61010 | ADMINISTRATIVE OFFICE | 283.84 | O |
| WEST | N62583 | CBC PORT HUENEME CA | | 19.39 | 238 | 31ST NCR MCB ADMIN CLRM STOR | 61010 | ADMINISTRATIVE OFFICE | 120.39 | O |
| WEST | N62583 | CBC PORT HUENEME CA | | 19.39 | 835 | ADMIN/TRAINING BLDG | 61010 | ADMINISTRATIVE OFFICE | 174.24 | O |
| WEST | N62583 | CBC PORT HUENEME CA | | 19.39 | 835 | ADMIN/TRAINING BLDG | 61010 | ADMINISTRATIVE OFFICE | 174.24 | O |
| WEST | N62583 | CBC PORT HUENEME CA | | 19.39 | 836 | 31 ST NCR/NSFA | 61010 | ADMINISTRATIVE OFFICE | 172.35 | O |
| WEST | N62583 | CBC PORT HUENEME CA | | 19.39 | 836 | 31 ST NCR/NSFA | 61010 | ADMINISTRATIVE OFFICE | 172.35 | O |
| WEST | N62583 | CBC PORT HUENEME CA | | 19.39 | 352 | VEH MAINT 31 NCR/R-60 | 17120 | APPLIED INSTRUCTION BLDG | 121.48 | T |
| WEST | N63126 | PACMISTESTCEN | PT HUGU CA | 19.44 | 20 | SUBSISTENCE BLDG | 72210 | ENLISTED DINING FACILITY | 417.54 | D |
| WEST | N63126 | PACMISTESTCEN | PT HUGU CA | 19.44 | 36 | ADMIN SHOP/LAB BLDG | 61010 | ADMINISTRATIVE OFFICE | 886.77 | O |
| WEST | N63387 | PWC SAN DIEGO CA | | 15.26 | 12 | PUBLIC QUARTERS | 71120 | WHERRY HSG,ENLISTED | 118.15 | F |
| WEST | N63387 | PWC SAN DIEGO CA | | 15.26 | 86 | PUBLIC QUARTERS | 71120 | WHERRY HSG,ENLISTED | 114.70 | F |
| WEST | N63387 | PWC SAN DIEGO CA | | 15.26 | 81 | PUBLIC QUARTERS | 71120 | WHERRY HSG,ENLISTED | 114.70 | F |
| WEST | N63387 | PWC SAN DIEGO CA | | 15.26 | 30 | PUBLIC QUARTERS | 71120 | WHERRY HSG,ENLISTED | 114.70 | F |
| WEST | N63387 | PWC SAN DIEGO CA | | 15.26 | 29 | PUBLIC QUARTERS | 71120 | WHERRY HSG,ENLISTED | 114.70 | F |
| WEST | N63387 | PWC SAN DIEGO CA | | 15.26 | 10 | PUBLIC QUARTERS | 71120 | WHERRY HSG,ENLISTED | 114.70 | F |
| WEST | N63387 | PWC SAN DIEGO CA | | 15.26 | 17 | PUBLIC QUARTERS | 71120 | WHERRY HSG,ENLISTED | 117.74 | F |
| WEST | N63387 | PWC SAN DIEGO CA | | 15.26 | 16 | PUBLIC QUARTERS | 71120 | WHERRY HSG,ENLISTED | 104.84 | F |
| WEST | N63387 | PWC SAN DIEGO CA | | 15.26 | 14 | PUBLIC QUARTERS | 71120 | WHERRY HSG,ENLISTED | 104.84 | F |
| WEST | N63387 | PWC SAN DIEGO CA | | 15.26 | 13 | PUBLIC QUARTERS | 71120 | WHERRY HSG,ENLISTED | 104.84 | F |
| WEST | N63387 | PWC SAN DIEGO CA | | 15.26 | 93 | PUBLIC QUARTERS | 71120 | WHERRY HSG,ENLISTED | 101.04 | F |
| WEST | N63387 | PWC SAN DIEGO CA | | 15.26 | 87 | PUBLIC QUARTERS | 71120 | WHERRY HSG,ENLISTED | 114.88 | F |
| WEST | N63387 | PWC SAN DIEGO CA | | 15.26 | 80 | PUBLIC QUARTERS | 71120 | WHERRY HSG,ENLISTED | 114.88 | F |
| WEST | N63387 | PWC SAN DIEGO CA | | 15.26 | 28 | PUBLIC QUARTERS | 71120 | WHERRY HSG,ENLISTED | 101.04 | F |
| WEST | N63387 | PWC SAN DIEGO CA | | 15.26 | 26 | PUBLIC QUARTERS | 71120 | WHERRY HSG,ENLISTED | 114.88 | F |
| WEST | N63387 | PWC SAN DIEGO CA | | 15.26 | 43 | PUBLIC QUARTERS | 71120 | WHERRY HSG,ENLISTED | 114.88 | F |
| WEST | N63387 | PWC SAN DIEGO CA | | 15.26 | 15 | PUBLIC QUARTERS | 71120 | WHERRY HSG,ENLISTED | 101.04 | F |

| | | | | | | | | | |
|------|--------|-------------------------------|-------|------|------------------------------|-------|------------------------------|---------|---|
| WEST | N63387 | PVC SAN DIEGO CA | 15.26 | 11 | PUBLIC QUARTERS | 71120 | WHERRY HSG, ENLISTED | 101.04 | F |
| WEST | N63387 | PVC SAN DIEGO CA | 15.26 | 9 | PUBLIC QUARTERS | 71120 | WHERRY HSG, ENLISTED | 114.88 | F |
| WEST | N63387 | PVC SAN DIEGO CA | 15.26 | 8 | PUBLIC QUARTERS | 71120 | WHERRY HSG, ENLISTED | 114.88 | F |
| WEST | N63387 | PVC SAN DIEGO CA | 15.26 | 7 | PUBLIC QUARTERS | 71120 | WHERRY HSG, ENLISTED | 114.88 | F |
| WEST | N63387 | PVC SAN DIEGO CA | 15.26 | 6 | PUBLIC QUARTERS | 71120 | WHERRY HSG, ENLISTED | 114.88 | F |
| WEST | N63387 | PVC SAN DIEGO CA | 15.26 | 5 | PUBLIC QUARTERS | 71120 | WHERRY HSG, ENLISTED | 114.88 | F |
| WEST | N63387 | PVC SAN DIEGO CA | 15.26 | 2 | PUBLIC QUARTERS | 71120 | WHERRY HSG, ENLISTED | 101.04 | F |
| WEST | N63387 | PVC SAN DIEGO CA | 15.26 | 1 | PUBLIC QUARTERS | 71120 | WHERRY HSG, ENLISTED | 116.17 | F |
| WEST | N63387 | PVC SAN DIEGO CA | 15.26 | 3 | PUBLIC QUARTERS | 71120 | WHERRY HSG, ENLISTED | 118.36 | O |
| WEST | N63387 | PVC SAN DIEGO CA | 15.26 | 120 | ADMIN | 61010 | ADMINISTRATIVE OFFICE | 133.37 | O |
| WEST | N63394 | SHIPPHYSSENGSTA PT HUENEME CA | 20.61 | 445 | ADMINISTRATION BLDG | 61010 | ADMINISTRATIVE OFFICE | 129.43 | B |
| WEST | N63406 | SUBASE SAN DIEGO CA | 15.57 | 500 | EM BARRACKS/AM MESS | 72111 | REQ E1/E4 | 169.06 | O |
| WEST | N63406 | SUBASE SAN DIEGO CA | 15.57 | 140 | INSTRUCTION/ADMIN BLDG | 61010 | ADMINISTRATIVE OFFICE | 169.06 | O |
| WEST | N63406 | SUBASE SAN DIEGO CA | 15.57 | 140 | INSTRUCTION/ADMIN BLDG | 61010 | ADMINISTRATIVE OFFICE | 234.71 | T |
| WEST | N63406 | SUBASE SAN DIEGO CA | 15.57 | 544 | SHIP COMT/SUBMARINE TRNG FAC | 17120 | APPLIED INSTRUCTION BLDG | 5101.79 | H |
| WEST | N68090 | NAVHOSP LONG BEACH CA | 15.21 | 9001 | HOSPITAL | 51010 | HOSPITAL | 5373.90 | H |
| WEST | N68094 | NAVHOSP CAMP PENDLETON CA | 27.60 | H100 | HOSPITAL | 51010 | HOSPITAL | 280.90 | O |
| WEST | N68305 | NAVCIVERGLAB PORT HUENEME CA | 19.73 | 560 | ADMIN-RO-T BLDG/OTHER | 61010 | ADMINISTRATIVE OFFICE | 257.13 | D |
| WEST | N68311 | NAVSTA LONG BEACH CA | 15.47 | 299 | MESS HALL | 72210 | ENLISTED DINING FACILITY | 110.59 | F |
| WEST | N68311 | NAVSTA LONG BEACH CA | 15.47 | 7001 | FAM HSG 111'S 8 UNIT | 71170 | FUND HSG, AFTER 69, ENLISTED | 110.59 | F |
| WEST | N68311 | NAVSTA LONG BEACH CA | 15.47 | 7003 | FAM HSG V'S 8 UNIT | 71170 | FUND HSG, AFTER 69, ENLISTED | 110.59 | F |
| WEST | N68311 | NAVSTA LONG BEACH CA | 15.47 | 7005 | FAM HSG V'S 8 UNIT | 71170 | FUND HSG, AFTER 69, ENLISTED | 110.59 | F |
| WEST | N68311 | NAVSTA LONG BEACH CA | 15.47 | 7006 | FAM HSG V'S 8 UNITS | 71140 | FUND HSG, PRE 1950, ENLISTED | 111.15 | F |
| WEST | N68311 | NAVSTA LONG BEACH CA | 15.47 | 7007 | FAM HSG V'S 8 UNIT | 71170 | FUND HSG, AFTER 69, ENLISTED | 110.59 | F |
| WEST | N68311 | NAVSTA LONG BEACH CA | 15.47 | 7015 | FAM HSG V'S 8 UNIT | 71170 | FUND HSG, AFTER 69, ENLISTED | 110.59 | F |
| WEST | N68311 | NAVSTA LONG BEACH CA | 15.47 | 7018 | FAM HSG V'S 8 UNIT | 71170 | FUND HSG, AFTER 69, ENLISTED | 110.59 | F |
| WEST | N68311 | NAVSTA LONG BEACH CA | 15.47 | 7022 | FAM HSG V N 8 UNIT | 71170 | FUND HSG, AFTER 69, ENLISTED | 110.59 | F |
| WEST | N68311 | NAVSTA LONG BEACH CA | 15.47 | 7025 | FAM HSG V N 8 UNIT | 71170 | FUND HSG, AFTER 69, ENLISTED | 110.59 | F |
| WEST | N68311 | NAVSTA LONG BEACH CA | 15.47 | 7026 | FAM HSG V N 8 UNIT | 71170 | FUND HSG, AFTER 69, ENLISTED | 110.59 | F |
| WEST | N68311 | NAVSTA LONG BEACH CA | 15.47 | 7028 | FAM HSG VIN 8 UNIT | 71170 | FUND HSG, AFTER 69, ENLISTED | 110.59 | F |
| WEST | N68311 | NAVSTA LONG BEACH CA | 15.47 | 7029 | FAM HSG VI NR 8 UNIT | 71170 | FUND HSG, AFTER 69, ENLISTED | 119.26 | O |
| WEST | N68311 | NAVSTA LONG BEACH CA | 15.47 | 8 | EDUCATION CENTER/SUPPLY WHSE | 74088 | EDUCATIONL SERVICES OFFICE | 119.26 | O |
| WEST | N68311 | NAVSTA LONG BEACH CA | 15.47 | 8 | EDUCATION CENTER/SUPPLY WHSE | 74088 | EDUCATIONL SERVICES OFFICE | 119.26 | O |
| WEST | N68311 | NAVSTA LONG BEACH CA | 15.47 | 8 | EDUCATION CENTER/SUPPLY WHSE | 74088 | EDUCATIONL SERVICES OFFICE | 119.26 | O |
| WEST | N68311 | NAVSTA LONG BEACH CA | 15.47 | 1 | ADMINISTRATION BUILDING | 61010 | ADMINISTRATIVE OFFICE | 244.25 | O |
| WEST | N68311 | NAVSTA LONG BEACH CA | 15.47 | 1 | ADMINISTRATION BUILDING | 61010 | ADMINISTRATIVE OFFICE | 244.25 | O |
| WEST | N68311 | NAVSTA LONG BEACH CA | 15.47 | 676 | RESERVE CENTER | 17115 | RESERVE TRAINING BUILDING | 232.91 | T |
| CHES | N00167 | DTRCEN BETHESDA MD | 18.02 | 121 | OFFICE BUILDING | 61010 | ADMINISTRATIVE OFFICE | 109.92 | O |
| CHES | N00174 | NAVORDSTA INDIAN HEAD MD | 16.04 | D323 | ENG OFFICE/DATA PROCESS CTR | 61010 | ADMINISTRATIVE OFFICE | 119.17 | O |
| CHES | N00174 | NAVORDSTA INDIAN HEAD MD | 16.04 | 900 | NAVSCOLEO DIV 6 | 17120 | APPLIED INSTRUCTION BLDG | 323.12 | T |
| CHES | N00174 | NAVORDSTA INDIAN HEAD MD | 16.04 | 900 | NAVSCOLEO | 17120 | APPLIED INSTRUCTION BLDG | 250.00 | T |
| PAC | M62613 | MCAS IWAKUNI JA | 36.08 | 221 | SUBSISTENCE BUILDING | 72210 | ENLISTED DINING FACILITY | 317.06 | D |
| PAC | M62613 | MCAS IWAKUNI JA | 36.08 | 1562 | DINING HALL NO 2 | 72210 | ENLISTED DINING FACILITY | 230.08 | D |
| PAC | M62613 | MCAS IWAKUNI JA | 36.08 | 906 | FAM QTRS- MIDRISE- MNZN | 71155 | FOR'N SOURCE HSG, ENLISTED | 604.82 | F |
| PAC | M62613 | MCAS IWAKUNI JA | 36.08 | 955 | FAM QTRS- MIDRISE- MNZN | 71155 | FOR'N SOURCE HSG, ENLISTED | 604.82 | F |
| PAC | M62613 | MCAS IWAKUNI JA | 36.08 | 1200 | FAM QTRS- MIDRISE- #3 | 71157 | FOR'N SOURCE HSG, 0-4, 0-5 | 604.82 | F |
| PAC | M62613 | MCAS IWAKUNI JA | 36.08 | 589 | FAM QTRS- MIDRISE- #4 | 71155 | FOR'N SOURCE HSG, ENLISTED | 596.70 | F |
| PAC | M62613 | MCAS IWAKUNI JA | 36.08 | 125 | DISPENSARY BUILDING | 51015 | HOSPITAL BR/ANEX | 247.06 | H |
| PAC | M62613 | MCAS IWAKUNI JA | 36.08 | 163 | LOGISTICS/CMPTLR/RJE/MCX | 61010 | LOGISTICS/COMPTLR/NAFAS | 100.87 | O |
| PAC | M62613 | MCAS IWAKUNI JA | 36.08 | 163 | LOGISTICS/CMPTLR/RJE/MCX | 61010 | USAEDJ IWAKUNI PROJ OFF | 100.87 | O |
| PAC | M62613 | MCAS IWAKUNI JA | 36.08 | 210 | EDUCATION & SERVICES BLDG | 74088 | JOINT EDY JAPANESE/AM SOC | 208.64 | O |
| PAC | M62613 | MCAS IWAKUNI JA | 36.08 | 360 | MCAS HEADQUARTERS | 61010 | MCAS & H&S HQ | 106.98 | O |
| PAC | M62613 | MCAS IWAKUNI JA | 36.08 | 367 | JMSOF HEADQUARTERS | 61010 | ADMINISTRATIVE OFFICE | 112.96 | O |
| PAC | M67385 | CAMP H M SMITH HI | 18.33 | 12 | MESS HALL | 72210 | ENLISTED DINING FACILITY | 127.91 | O |
| PAC | M67385 | CAMP H M SMITH HI | 18.33 | 1 | ADMINISTRATION BUILDING | 61010 | CINCPAC ADMIN SPACE | 248.17 | O |
| PAC | M67385 | CAMP H M SMITH HI | 18.33 | 1 | ADMINISTRATION BUILDING | 61010 | FMPAC ADMIN SPACE | 248.17 | O |
| PAC | M67385 | CAMP H M SMITH HI | 18.33 | 4C | ADM BLDG | 61010 | FMPAC ADMIN SPACE | 130.39 | U |
| PAC | M67385 | CAMP H M SMITH HI | 18.33 | 2C | ADM BLDG | 61010 | CINCPAC ADMIN SPACE | 136.39 | O |

| | | | | | | | | | |
|-----|--------|--------------------------------|-------|-------|-------------------------------|-------|-------------------------------|---------|---|
| PAC | M67385 | CAMP H M SMITH HI | 18.33 | 2D | ADM BUILDING | 61010 | CINCPAC ADMIN SPACE | 136.39 | O |
| PAC | M67385 | CAMP H M SMITH HI | 18.33 | 2D | ADM BUILDING | 61010 | FMPAC ADMIN SPACE | 136.39 | O |
| PAC | M67385 | CAMP H M SMITH HI | 18.33 | 3A | ADM BLDG | 61010 | FMPAC/CAMP SMITH ADMIN | 111.91 | O |
| PAC | M67385 | CAMP H M SMITH HI | 18.33 | 3A | ADM BLDG | 61010 | CINCPAC ADMIN SPACE | 111.91 | O |
| PAC | M67385 | CAMP H M SMITH HI | 18.33 | 3B | OFFICES | 61010 | FMPAC ADMIN SPACE | 102.29 | O |
| PAC | M67385 | CAMP H M SMITH HI | 18.33 | 3B | OFFICES | 61010 | CINCPAC ADMIN SPACE | 102.29 | O |
| PAC | M67385 | CAMP H M SMITH HI | 18.33 | 4 | SUBSISTENCE BLDG | 61010 | ADMIN SPACE USCINCPAC | 336.00 | O |
| PAC | M67385 | CAMP H M SMITH HI | 18.33 | 4 | SUBSISTENCE BLDG | 61010 | FMPAC ADMIN SPACE | 336.00 | O |
| PAC | M67385 | CAMP H M SMITH HI | 18.33 | 35 | ADM BLDG | 61010 | CINCPAC SYS DIR OFFICES | 103.47 | O |
| PAC | M67400 | MCB CAMP S D BUTLER OKINAWA JA | 39.67 | 431 | BOQ | 72111 | BEQ E1/E4 | 117.55 | 8 |
| PAC | M67400 | MCB CAMP S D BUTLER OKINAWA JA | 39.67 | 431 | BOQ | 72111 | UEPH, W1-02 | 111.58 | B |
| PAC | M67400 | MCB CAMP S D BUTLER OKINAWA JA | 39.67 | 1470 | BEQ, EM BRXS | 72411 | UEPH, E-1/E-4 | 101.39 | 8 |
| PAC | M67400 | MCB CAMP S D BUTLER OKINAWA JA | 39.67 | 4450 | DINING FAC | 72210 | ENLISTED DINING FACILITY | 234.49 | D |
| PAC | M67400 | MCB CAMP S D BUTLER OKINAWA JA | 39.67 | 3322 | DINING FAC | 72210 | ENLISTED DINING FACILITY | 234.49 | D |
| PAC | M67400 | MCB CAMP S D BUTLER OKINAWA JA | 39.67 | 3613 | DINING FAC | 72210 | ENLISTED DINING FACILITY | 234.49 | D |
| PAC | M67400 | MCB CAMP S D BUTLER OKINAWA JA | 39.67 | 2601 | DINING FAC | 72210 | ENLISTED DINING FACILITY | 234.49 | D |
| PAC | M67400 | MCB CAMP S D BUTLER OKINAWA JA | 39.67 | 2303 | 9TH ES BN DINING FAC | 72210 | ENLISTED DINING FACILITY | 234.49 | D |
| PAC | M67400 | MCB CAMP S D BUTLER OKINAWA JA | 39.67 | 2324 | HQ CO 9TH MAR DINING FAC | 72210 | ENLISTED DINING FACILITY | 234.49 | D |
| PAC | M67400 | MCB CAMP S D BUTLER OKINAWA JA | 39.67 | 2632 | DINING FAC | 72210 | ENLISTED DINING FACILITY | 213.88 | D |
| PAC | M67400 | MCB CAMP S D BUTLER OKINAWA JA | 39.67 | 4328 | HO/BN DINING FACILITY | 72210 | ENLISTED DINING FACILITY | 234.49 | D |
| PAC | M67400 | MCB CAMP S D BUTLER OKINAWA JA | 39.67 | 2343 | MESS BUILDING MCB | 72210 | ENLISTED DINING FACILITY | 234.49 | D |
| PAC | M67400 | MCB CAMP S D BUTLER OKINAWA JA | 39.67 | 423 | SUBSISTENCE BUILDING | 72210 | ENLISTED DINING FACILITY | 326.13 | D |
| PAC | M67400 | MCB CAMP S D BUTLER OKINAWA JA | 39.67 | 20 | BEQ/MESS HALL/BN OFFICE | 72210 | ENLISTED DINING FACILITY | 326.19 | D |
| PAC | M67400 | MCB CAMP S D BUTLER OKINAWA JA | 39.67 | 200 | DINING FAC | 72210 | ENLISTED DINING FACILITY | 319.96 | D |
| PAC | M67400 | MCB CAMP S D BUTLER OKINAWA JA | 39.67 | 488 | DINING FAC | 72210 | DET DINING FAC, ENLSTD MEN | 319.96 | D |
| PAC | M67400 | MCB CAMP S D BUTLER OKINAWA JA | 39.67 | 1223 | DINING FACILITY | 72210 | DET DINING FAC, ENLSTD MEN | 319.96 | D |
| PAC | M67400 | MCB CAMP S D BUTLER OKINAWA JA | 39.67 | 280 | MESSHALL | 72210 | ENLISTED DINING FACILITY | 369.27 | D |
| PAC | M67400 | MCB CAMP S D BUTLER OKINAWA JA | 39.67 | 4506 | FAMILY HOUSING HIGHRISE | 71155 | FOR 'N SOURCE HSG, ENLISTED | 924.14 | F |
| PAC | M67400 | MCB CAMP S D BUTLER OKINAWA JA | 39.67 | 4511 | FAMILY HOUSING HIGHRISE | 71155 | FOR 'N SOURCE HSG, WO, 0-1/03 | 924.14 | F |
| PAC | M67400 | MCB CAMP S D BUTLER OKINAWA JA | 39.67 | 4513 | FAMILY HOUSING HIGHRISE | 71155 | FOR 'N SOURCE HSG, ENLISTED | 924.14 | F |
| PAC | M67400 | MCB CAMP S D BUTLER OKINAWA JA | 39.67 | 4528 | FAMILY HOUSING HIGHRISE | 71155 | FOR 'N SOURCE HSG, ENLISTED | 924.14 | F |
| PAC | M67400 | MCB CAMP S D BUTLER OKINAWA JA | 39.67 | 4531 | FAMILY HOUSING HIGHRISE | 71155 | FOR 'N SOURCE HSG, ENLISTED | 924.14 | F |
| PAC | M67400 | MCB CAMP S D BUTLER OKINAWA JA | 39.67 | 4533 | FAMILY HOUSING HIGHRISE | 71155 | FOR 'N SOURCE HSG, ENLISTED | 924.14 | F |
| PAC | M67400 | MCB CAMP S D BUTLER OKINAWA JA | 39.67 | 858 | FAMILY HOUSING, HIGHRISE | 71155 | FOREIGN SOURCE HSG, ENL | 889.62 | F |
| PAC | M67400 | MCB CAMP S D BUTLER OKINAWA JA | 39.67 | 859 | FAMILY HOUSING, HIGHRISE | 71155 | FOREIGN SOURCE HSG, ENL | 889.62 | F |
| PAC | M67400 | MCB CAMP S D BUTLER OKINAWA JA | 39.67 | 867 | FAMILY HOUSING HIGHRISE | 71155 | FOREIGN SOURCE HSG, ENL | 889.62 | F |
| PAC | M67400 | MCB CAMP S D BUTLER OKINAWA JA | 39.67 | 868 | FAMILY HOUSING HIGHRISE | 71155 | FOREIGN SOURCE HSG, ENL | 889.62 | F |
| PAC | M67400 | MCB CAMP S D BUTLER OKINAWA JA | 39.67 | 872 | FAMILY HOUSING HIGHRISE | 71155 | FOREIGN SOURCE HSG, ENL | 889.62 | F |
| PAC | M67400 | MCB CAMP S D BUTLER OKINAWA JA | 39.67 | 871 | FAMILY HOUSING HIGHRISE | 71155 | FOREIGN SOURCE HSG, ENL | 889.62 | F |
| PAC | M67400 | MCB CAMP S D BUTLER OKINAWA JA | 39.67 | 6000 | HOSPITAL | 51010 | FOREIGN SOURCE HSG ENL | 3198.54 | H |
| PAC | M67400 | MCB CAMP S D BUTLER OKINAWA JA | 39.67 | 6043 | ALCOHOL REHAB SERVICE | 51010 | HOSPITAL | 235.23 | H |
| PAC | M67400 | MCB CAMP S D BUTLER OKINAWA JA | 39.67 | 1 | MCB HEADQUARTERS BLDG | 61010 | ADMINISTRATIVE OFFICE | 287.46 | O |
| PAC | M61119 | NSD GUAM GQ | 24.49 | 3190 | ADMIN BLDG - NSD | 61010 | ADMINISTRATIVE OFFICE | 376.31 | O |
| PAC | M61577 | NAS AGANA GUAM | 19.52 | 13-8A | MESS HALL | 72210 | ENLISTED DINING FACILITY | 132.94 | O |
| PAC | M61577 | NAS AGANA GUAM | 19.52 | 17-80 | NOSE DOCK, SHOP/OFFICE BLDG | 61010 | CICC FIELD OFFICE | 469.81 | D |
| PAC | M61581 | COMFLEACT YOKOSUKA JA | 25.45 | 1557 | ENLISTED MEN'S DINING FAC | 72210 | ENLISTED MEN'S DINING FAC | 146.85 | O |
| PAC | M61581 | COMFLEACT YOKOSUKA JA | 25.45 | B39A | ADMINISTRATIVE BLDG | 61010 | ADMIN OFFICE-NISO | 240.48 | D |
| PAC | M61581 | COMFLEACT YOKOSUKA JA | 25.45 | B39A | ADMINISTRATIVE BLDG | 61010 | ADMIN OFFICE-NISO | 128.94 | O |
| PAC | M61581 | COMFLEACT YOKOSUKA JA | 25.45 | 1555 | ADMINISTRATION BUILDING | 61010 | ADMINISTRATIVE OFFICE-NCS | 128.94 | O |
| PAC | M61581 | COMFLEACT YOKOSUKA JA | 25.45 | 1555 | ADMINISTRATION BUILDING | 61010 | ADMINISTRATIVE OFFICE | 207.87 | O |
| PAC | M61755 | NAVSTA GUAM GQ | 19.56 | 4175 | BCHLR CIV QTR/CCPO/NLSOY/BAND | 72111 | BEQ E1/E4 | 207.87 | O |
| PAC | M61755 | NAVSTA GUAM GQ | 19.56 | SB1 | SUBSISTENCE BLDG/DIST 1 REC | 72210 | ENLISTED DINING FACILITY | 122.62 | B |
| PAC | M61755 | NAVSTA GUAM GQ | 19.56 | 522 | CB DINING FAC-EM | 72210 | ENLISTED DINING FACILITY | 472.96 | D |
| PAC | M61755 | NAVSTA GUAM GQ | 19.56 | 200 | CONNAVMAR/JFAC/MSG CTR | 61010 | CONNAVMAR ADMIN OFC | 106.03 | D |
| PAC | M62395 | PWC GUAM | 24.28 | B103 | ADMINISTRATION BUILDING | 61010 | ADMINISTRATIVE OFFICE | 203.60 | O |
| PAC | M62507 | NAF ATSUGI JA | 35.19 | 988 | UEPH | 72111 | UEPH E-1 THRU E-4 | 100.46 | O |
| PAC | M62507 | NAF ATSUGI JA | 35.19 | 108 | MESSHALL | 72210 | ENLISTED DINING FACILITY | 111.40 | B |
| PAC | M62507 | NAF ATSUGI JA | 35.19 | Y03 | EM BULLET | 72210 | ENLISTED DINING FACILITY | 168.18 | D |
| PAC | M62507 | NAF ATSUGI JA | 35.19 | 293 | MOG/APARTMENT/ | 71131 | FUND HSG, 1950/69, WO, 0-1/03 | 1/2.63 | U |
| PAC | M62507 | NAF ATSUGI JA | 35.19 | 293 | MOG/APARTMENT/ | 71131 | FUND HSG, 1950/69, WO, 0-1/03 | 102.20 | F |

| PAC | NAF | ATSUGI | JA | MEMQ | 35.19 | 914 | 71155 | FOR 'N SOURCE | HSG, ENLISTED | 303.60 | F |
|-----|--------|---------------|--------------|------|-------|------|-------|--------------------------|---------------|---------|---|
| PAC | N62507 | NAF | ATSUGI | JA | 35.19 | 3042 | 71155 | FOR 'N SOURCE | HSG, ENLISTED | 456.21 | F |
| PAC | N62507 | NAF | ATSUGI | JA | 35.19 | 3043 | 71155 | FOR 'N SOURCE | HSG, ENLISTED | 456.21 | F |
| PAC | N62507 | NAF | ATSUGI | JA | 35.19 | 66 | 61010 | ADMINISTRATIVE OFFICE | | 103.06 | O |
| PAC | N62507 | NAF | ATSUGI | JA | 35.19 | 101 | 61010 | ADMINISTRATIVE OFFICE | | 153.42 | O |
| PAC | N62507 | NAF | ATSUGI | JA | 35.19 | 970 | 61010 | ADMINISTRATIVE OFFICE | | 111.51 | O |
| PAC | N62735 | COMFLEACT | SASEBO | JA | 46.08 | 569 | 71155 | FOR 'N SOURCE | HSG, ENLISTED | 212.00 | F |
| PAC | N62735 | COMFLEACT | SASEBO | JA | 46.08 | 1512 | 71155 | FOR 'N SOURCE | HSG, ENLISTED | 599.41 | F |
| PAC | N62735 | COMFLEACT | SASEBO | JA | 46.08 | 5028 | 71155 | FOR 'N SOURCE | HSG, ENLISTED | 743.38 | F |
| PAC | N62758 | NAVSHIPREFPAC | YOKOSUKA | JA | 20.03 | A40 | 61010 | ADMIN OFFICE | | 173.15 | O |
| PAC | N62758 | NAVSHIPREFPAC | YOKOSUKA | JA | 20.03 | A40 | 61010 | ADMIN OFFICE, NEEACT | | 173.15 | O |
| PAC | N65115 | PWC | YOKOSUKA | JA | 21.50 | C22 | 71158 | FOR 'N SOURCE | HSG, O-6 | 132.10 | F |
| PAC | N65115 | PWC | YOKOSUKA | JA | 21.50 | H34 | 71155 | FOR 'N SOURCE | HSG, ENLISTED | 219.62 | F |
| PAC | N65115 | PWC | YOKOSUKA | JA | 21.50 | H35 | 71155 | FOR 'N SOURCE | HSG, ENLISTED | 251.36 | F |
| PAC | N65115 | PWC | YOKOSUKA | JA | 21.50 | H37 | 71155 | FOR 'N SOURCE | HSG, ENLISTED | 147.87 | F |
| PAC | N65115 | PWC | YOKOSUKA | JA | 21.50 | H40 | 71155 | FOR 'N SOURCE | HSG, ENLISTED | 523.55 | F |
| PAC | N65115 | PWC | YOKOSUKA | JA | 21.50 | 1150 | 71155 | FOR 'N SOURCE | HSG, ENLISTED | 450.64 | F |
| PAC | N65115 | PWC | YOKOSUKA | JA | 21.50 | 1151 | 71155 | FOR 'N SOURCE | HSG, ENLISTED | 450.64 | F |
| PAC | N65115 | PWC | YOKOSUKA | JA | 21.50 | 1152 | 71155 | FOR 'N SOURCE | HSG, ENLISTED | 450.64 | F |
| PAC | N65115 | PWC | YOKOSUKA | JA | 21.50 | 1147 | 71155 | FOR 'N SOURCE | HSG, ENLISTED | 450.64 | F |
| PAC | N65115 | PWC | YOKOSUKA | JA | 21.50 | 1148 | 71155 | FOR 'N SOURCE | HSG, ENLISTED | 450.64 | F |
| PAC | N65115 | PWC | YOKOSUKA | JA | 21.50 | 1149 | 71155 | FOR 'N SOURCE | HSG, ENLISTED | 450.64 | F |
| PAC | N65115 | PWC | YOKOSUKA | JA | 21.50 | 1315 | 71155 | FOR 'N SOURCE | HSG, ENLISTED | 450.64 | F |
| PAC | N65115 | PWC | YOKOSUKA | JA | 21.50 | 1316 | 71155 | FOR 'N SOURCE | HSG, ENLISTED | 450.64 | F |
| PAC | N65115 | PWC | YOKOSUKA | JA | 21.50 | 1516 | 71155 | FOR 'N SOURCE | HSG, ENLISTED | 506.58 | F |
| PAC | N65115 | PWC | YOKOSUKA | JA | 21.50 | 1517 | 71155 | FOR 'N SOURCE | HSG, ENLISTED | 506.58 | F |
| PAC | N68096 | NAVHOSP | GUAM | | 19.46 | 1 | 51010 | HOSPITAL | | 3841.15 | H |
| PAC | N68292 | NAVHOSP | YOKOSUKA | JA | 28.56 | E22 | 51010 | HOSP-ARS/PREV MED | | 338.60 | H |
| PAC | N68292 | NAVHOSP | YOKOSUKA | JA | 28.56 | 1400 | 51010 | HOSPITAL | | 2906.47 | H |
| PAC | N70243 | NAV CAMS | WESTPAC GUAM | GO | 19.36 | 122 | 72210 | ENLISTED DINING FACILITY | | 239.63 | D |

Type Indicators: O - Office
S - Retail Stores
H - Hospitals
T - Training
F - Mult-Family Residences
B - BOQ/BEQ
L - Laundries
D - Dining
P - Pools

Criteria for Acceptance: Thermal Requirement > 100 Kbtu/hr
Electrical to Thermal Cost Differential) \$15/Mbtu

Summary by Facility Type

| Facility Type | Number of Facilities |
|------------------------|----------------------|
| Office | 150 |
| Retail Stores | 0 |
| Hospitals | 23 |
| Training | 67 |
| Mult-Family Residences | 145 |
| BOQ/BEQ | 38 |
| Laundries | 0 |
| Dining | 81 |
| Pools | 3 |
| total | 507 |

Appendix B

ANNUAL PERFORMANCE REPORT FOR
NAVAL STATION, TREASURE ISLAND

LETTER REPORT

ANNUAL PERFORMANCE OF TECOGEN 60kWe COGENERATION MODULE
AT NAVAL STATION, TREASURE ISLAND, SAN FRANCISCO BAY

Prepared By

T. Richard Lee, Ph.D., P.E.

September 1988



NAVAL CIVIL ENGINEERING LABORATORY
PORT HUENEME, CALIFORNIA 93043
FOR OFFICIAL USE ONLY.

TABLE OF CONTENTS

| | Page |
|---|------|
| 1.0 INTRODUCTION/BACKGROUND | 1 |
| 2.0 DESCRIPTION OF THE COGENERATION SYSTEM | 1 |
| 2.1 TECOGEN Cogeneration Module | 1 |
| 2.2 Data Monitoring System | 2 |
| 3.0 METHODOLOGIES FOR EVALUATING THE TECOGEN PERFORMANCE | 3 |
| 3.1 System Performance Calculations | 3 |
| 3.2 Economic Benefits Calculations | 3 |
| 4.0 OPERATIONAL DATA OF THE COGENERATION SYSTEM | 5 |
| 4.1 System Performance | 5 |
| 4.2 Economic Benefits | 6 |
| 5.0 CONCLUSIONS | 6 |
| APPENDICES | |
| A - Equations for the Calculation of Energy Balance | A-1 |
| B - System Performance Parameters | B-1 |

LIST OF FIGURES

| | Page |
|---|------|
| Figure 1. TECOGEN Cogeneration Unit Specifications and Energy Balance | 7 |
| Figure 2. Schematic of TECOGEN Module | 8 |
| Figure 3. Simplified Diagram of Cogeneration System at Building 261, NS, Treasure Island, SF | 9 |
| Figure 4. Display of the TECOGEN Operational Data Monitored on the Computer Screen | 10 |
| Figure 5. Average Energy Distribution from the TECOGEN | 11 |
| Figure 6. Monthly Thermal Output from the TECOGEN | 12 |
| Figure 7. Monthly Electric Output from the TECOGEN | 13 |
| Figure 8. Monthly Operating Hours of the TECOGEN | 14 |
| Figure 9. Annual Savings in Energy Costs | 15 |

LIST OF TABLES

| | Page |
|---|------|
| Table 1. TECOGEN Operational Data from September 1987 to August 1988 | 16 |
| Table 2. Cost Benefits from the Operation of TECOGEN | 17 |

1.0 INTRODUCTION/BACKGROUND

The Naval Facilities Engineering Command (NAVFAC) has tasked the Naval Civil Engineering Laboratory (NCEL), as part of the Navy Shore Facilities Energy R&D Program, to evaluate the packaged cogeneration systems (PCS) technology in terms of performance, operation and maintenance, and life cycle costs. Presently, a small cogeneration unit is being monitored for its performance in Building 261 (swimming pool) at Naval Station, Treasure Island in the San Francisco Bay. The TECOGEN unit with a rated capacity of 60 kW was purchased and installed by Pacific Gas and Electric Company, a California corporation (PG&E), under an agreement with the Navy as a three-year R&D program. The performance of the cogeneration system is being monitored by the Department of Engineering Research of PG&E through a microprocessor remote monitoring system. The system service and maintenance is provided by the local TECOGEN maintenance personnel through an agreement with PG&E.

The purpose of this letter report is to document the system performance and the estimated economic benefit during the first year of operation from September 1987 to August 1988. A description of the TECOGEN system and the methodologies used for the system evaluation are also provided.

At the time of preparation of this report, the maintenance records were not made available to NCEL by Thermo Electron. Therefore, no reliability and maintainability calculations are given in this report.

2.0 DESCRIPTION OF THE COGENERATION SYSTEM

2.1 TECOGEN Cogeneration Module

The cogeneration module monitored at Treasure Island is a 60 kW unit commercially known as "TECOGEN CM-60". The prime mover is a reciprocating internal combustion engine driven by natural gas. The engine drives an induction generator to produce electricity that is delivered to the base electric distribution system. The thermal energy recovered from the engine exhaust, jacket cooling water and lubricating oil is delivered to the domestic hot water (DHW) tank and the swimming pool. The thermal output of the unit is rated at 440,000 Btu/hr. The cogeneration module specifications, along with a schematic of the module energy balance, are shown in Figure 1.

The whole cogeneration unit can be viewed as four interconnected submodules. A schematic representation of the unit including these four modules is shown in Figure 2. The Engine Generator Submodule (EGS) consists of a natural gas-fired V-8 automotive engine driving an induction generator through a flywheel mounted coupling. The engine drives the generator slightly above 1800 rpm at which speed the generator starts

delivering electricity to the Electrical Interface Submodule (EIS).

The Heat Transfer Submodule (HTS) includes equipment for recovering heat from the engine exhaust, jacket water, and lubricating oil. The return water from the thermal load flows first to the oil cooler because it is the lowest temperature heat source. Next, it flows to the engine jacket cooler, then to the engine exhaust gas cooler, and finally through the exhaust manifolds before going to the external load. The heat exchangers used in the lubrication oil and the jacket water heat recovery are of the shell-and-tube type, whereas, for the exhaust gas recovery a finned coil of copper tubing in a steel cylinder is used.

The function of the Electrical Interface Submodule (EIS) is to control the flow of electric power between the cogeneration unit and the base electric distribution system. The module also provides a number of other safety and control-related functions such as the engine cranking control, engine ignition control, battery charging, and natural gas valve control.

The Control Submodule (CS) is a microprocessor-based system which acts as the brain of the cogeneration unit. It starts the system when there is a demand for heat and shuts it down when the demand is satisfied. In addition, the CS monitors the output of a large number of sensors and shuts the system down if preset limits are exceeded.

The thermal output from the cogeneration unit is used first for meeting the demand of the domestic hot water (DHW) tank and then the swimming pool. The cogeneration unit is thermally dispatched (thermal following mode) so that it will shut down automatically when there is no thermal demand from the DHW tank or the pool. A schematic of the arrangement of the cogeneration unit with its connections to the DHW tank and the pool is shown in Figure 3.

2.2 Data Monitoring System

The monitoring system, which is connected through a modem to the computers at the PG&E and NCEL offices, records the following measured parameters:

1. Water flow rate
2. Water outlet temperature
3. Water inlet temperature
4. Gas flow rate
5. Gross electric power generated
6. Parasitic electric power consumed
7. Voltage for each phase of electric power
8. Current for each phase of electric power
9. State of where thermal load is going (DHW or pool)

10. State of any TECOGEN unit alarms.

All these measured data are displayed on the computer screen along with a flow diagram of the set up. An image of this screen is shown in Figure 4.

3.0 METHODOLOGIES FOR EVALUATING THE TECOGEN PERFORMANCE

The performance of the TECOGEN cogeneration module has been evaluated by examining the system performance and economic benefits due to the operation of the unit.

3.1 System Performance Calculations

The system performance is calculated by examining the energy balance of the TECOGEN module in terms of gas energy input, thermal energy output, electrical energy output, and parasitic electrical energy.

Based on these measured parameters, the following performance parameters are calculated:

1. Thermal energy delivered
2. Electric energy delivered
3. Parasitic electric energy used
4. Power factor
5. Thermal efficiency
6. Electric efficiency
7. Total system efficiency
8. Availability factors (running time, down time, etc.)

The equations for the calculation of energy balance are shown in Appendix A. The system performance data such as efficiencies, availability factor, operating factor, and utilization factor are defined and explained in Appendix B.

3.2 Economic Benefits Calculations

The economic benefits are calculated by comparing the costs of supplying heat to the pool and hot water tank with and without the operation of TECOGEN. The cost of supplying heat without cogeneration is the cost of natural gas used for producing steam. This steam, produced at a central boiler, is transported to the swimming pool through the steam lines. The cost of providing heat with cogeneration is the cost of gas used for cogeneration and the cost of electricity bought from the cogeneration unit. There is also revenue from the cogeneration consisting of the shelter and surveillance fee paid by PG&E (\$25,243 per year) and the savings due to the reduced purchased electricity from the grid.

There are a total of five inputs which are used in the

calculation of the economic benefits. These five are the following:

1. Value of electricity to the Navy
2. Value of heat to the Navy
3. Revenue from shelter and surveillance to the Navy
4. Cost of TECOGEN fuel to the Navy
5. Cost of TECOGEN electricity to the Navy

1. Value of electricity to the Navy

This value represents the highest cost of electricity avoided due to the operation of the TECOGEN unit. This is computed as follows:

$$\begin{aligned} \text{Value1 } (\$/\text{kWh}) &= \text{energy charge } (\$/\text{kWh}) \\ &\quad + (\text{demand charge } (\$/\text{kW}) * \text{TECO capacity}) \\ &\quad / (720 \text{ hours} * \text{TECO capacity}) \\ &= \text{energy charge} + \text{demand charge} / 720. \end{aligned}$$

$$\text{Annual value (dollars)} = \text{Value1} * \text{annual net kWh produced.}$$

2. Value of heat to the Navy

This value represents the cost of natural gas for producing steam that is avoided due to the operation of the TECOGEN unit. This is computed as value of heat in dollars per kWh of electricity produced by the TECOGEN unit.

$$\begin{aligned} \text{Value2 } (\$/\text{kWh}) &= \text{Value of heat put out by TECOGEN for each} \\ &\quad \text{kWh output} \\ &= \text{Heat output from TECOGEN (MBtu/hr)} / \text{TECOGEN} \\ &\quad \text{output (kW)} / \text{Eff(boiler)} / \text{Eff(Stmline)} * \\ &\quad \text{Cost of boiler fuel } (\$/\text{MBtu}) \end{aligned}$$

$$\text{Annual value (dollars)} = \text{Value2} * \text{annual net kWh produced.}$$

3. Revenue from shelter and surveillance

According to the Navy/PG&E Agreement, PG&E will pay Navy \$25,243 per year for providing shelter and surveillance for the TECOGEN unit for the duration of this program.

4. Cost of TECOGEN fuel to the Navy

This is the cost of the fuel purchased by the Navy for operating TECOGEN. The tariff for cogeneration G-55 is used for

computing this cost.

$$\begin{aligned} \text{Cost1 (\$/kWh)} &= \text{cost of fuel for TECOGEN for each kWh output} \\ &= \text{price of gas (\$/MBtu)} * \text{gas needed by} \\ &\quad \text{TECOGEN (MBtu/hr)} / \text{TECOGEN capacity (kW)} \end{aligned}$$

$$\text{Annual cost (dollars)} = \text{cost1} * \text{annual net kWh produced}$$

5. Cost of TECOGEN electricity to the Navy

This is the cost of the electricity from TECOGEN sold by PG&E to the Navy. It is computed as follows:

$$\begin{aligned} \text{Cost2 (\$/kWh)} &= \text{energy charge (\$/kWh)} + \text{demand charge} \\ &\quad (\$/\text{kW}) / 720 \text{ (hrs)} \end{aligned}$$

$$\text{Annual cost (dollars)} = \text{cost2} * \text{net annual kWh produced.}$$

The energy charge for the electricity produced by TECOGEN is set by PG&E and is different from the rates being charged to the regular customers.

The net annual benefit (dollars) to the Navy due to the operation of the TECOGEN unit is,

$$= (\text{Value1} + \text{Value2} - \text{Cost1} - \text{Cost2}) * \text{net annual kWh} + \text{Revenue}$$

4.0 OPERATIONAL DATA OF THE COGENERATION SYSTEM

4.1 System Performance

The energy balance and system performance data for the months of September 1987 through August 1988 are shown in Table 1. The annual energy distribution of the TECOGEN module is shown in Figure 5. The total thermal output and its distribution to DHW and pool during the twelve months are shown in Figure 6. The net monthly electric energy outputs during the same time period are shown in Figure 7.

The TECOGEN system operates when there is a thermal request for heat. This thermostatically controlled request is present about 95% of the time. During this heat request time the TECOGEN system should be operating. The unit was operating about 83% of the thermal request time. When the unit is operating, the thermal output is directed to the pool about 95% of the time and to the DHW about 5% of the time. The total hours of operation of the module during the twelve months are shown in Figure 8.

An examination of the compiled operating data shows that the unit is operating at an electrical efficiency of about 26 to 27% during the twelve months. These efficiency numbers are consistent with those in the manufacturer's specifications. The thermal efficiency calculated as the ratio of total heat output to the heating value of the gas is between 54 to 58% during the twelve months. The total combined efficiencies range from 81% to 85% as compared with the manufacturer's specification of 83.1%.

4.2 Economic Benefits

The energy savings were calculated using the procedures listed in Section 3.0. The TECOGEN module has generated 409,877 kWh during the 6,921 hours of operation from September 1987 through August 1988. Its thermal equivalent based on a conversion efficiency of .35, is $409877 * 3413 / (.35) = 3997$ MBtu/year. The savings in purchased gas energy is $3019 / (.8 * .9) = 4193$ MBtu/year. The additional natural gas for Tecogen is $(778.1 * 6921) = 5385$ MBtu/year. The net annual energy saving is $3997 + 4193 - 5385 = 2805$ MBtu/year.

Using the operational data for the twelve months, the economics benefits were calculated using the methodology given in Section 3.0. The results of the calculations are shown in Table 2.

5.0 CONCLUSIONS

The performance data for the first twelve months show that this cogeneration unit has been operated over 6900 hours at high efficiency as specified by the manufacturer. The natural gas consumption, electrical energy output, and thermal output of the TECOGEN were compared to the rated values on the annual basis. The average gas consumption rate for one year was 779 kBtu/hr while the rated value is 776 kBtu/hr. The average measured value for thermal output was 435 kBtu/hr which was 1% lower than the rated value of 440 kBtu/hr. The average measured electrical output was 60.6 kW which was 1% higher than the rated capacity of 60 kW.

The economic benefit was computed based on 6,921 total annual hours of operation. The results show that for an electric to gas cost differential of about \$10.0/MBtu (i.e. \$0.05/kWh for electricity and \$5/MBtu for gas) without considering a maintenance cost of \$1.00 per hour of operation and revenue from shelter and surveillance, there is a net annual saving of 14,532 dollars. If a maintenance cost of \$1.0 for every hour of operation is included, there will be a saving of about \$8,000/year for a \$10/MBtu cost differential and \$23,000/year for a \$20/MBtu cost differential as shown in Figure 9.

INPUT: 760 scfh of Natural Gas (1020 Btu/scf HHV)
OUTPUT: Electrical - 60 kW
 (208 V, 220-240 V, or 440-480 V; 3 phase, 60 Hz)
 Thermal - 440,000 Btu/hr hot water
 (18 gpm, 170°F in, 220°F out are typical)
EFFICIENCY: Electrical - 26.4%
 Combined Electrical and Thermal - 83.1%
DIMENSIONS: 82 in. long x 42 in. wide x 40 in. high
 (maximum width without acoustic enclosure - 35 in.)
WEIGHT: 3000 lb
CONTROLS: Completely automated via microprocessor-based
 control system. (Startup, monitoring, shutdown, etc.)
ACOUSTIC LEVEL: 70 dBA at 20 ft

TECOGEN COGENERATION MODULE ENERGY BALANCE

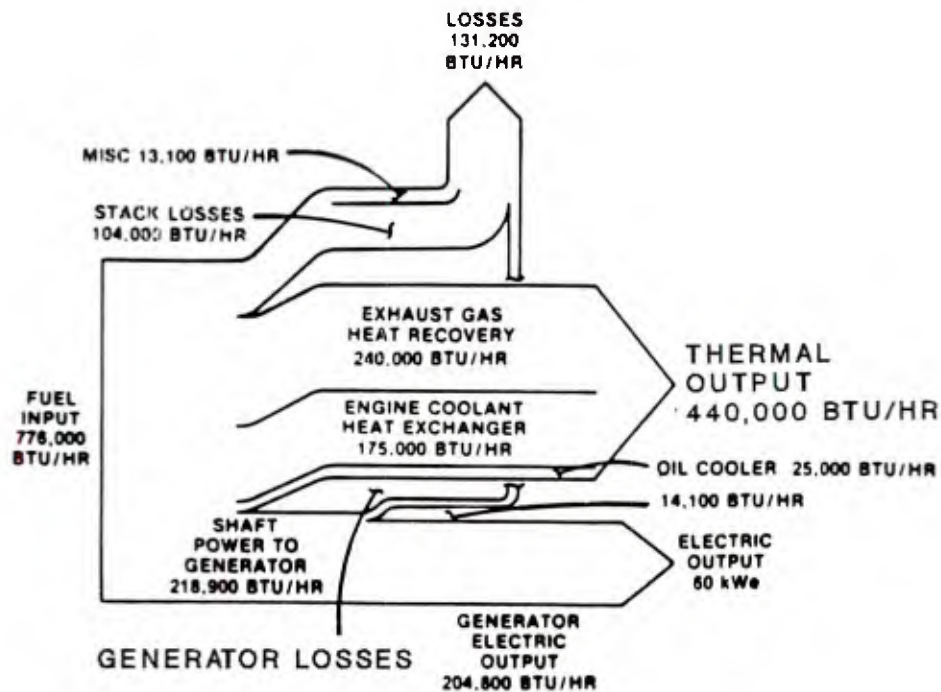

Figure 1. TECOGEN Cogeneration Unit Specifications and Energy Balance

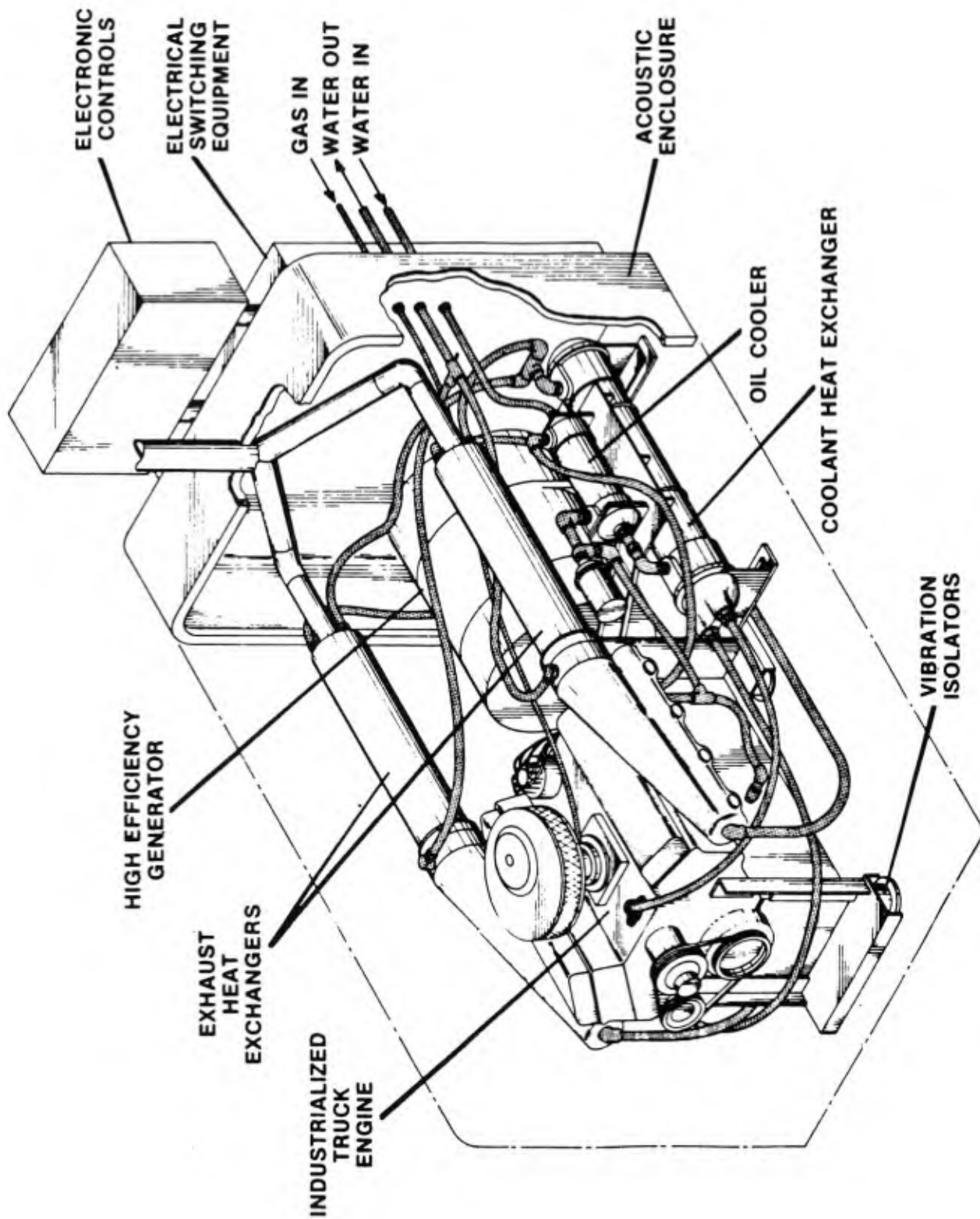

Figure 2. Schematic of TECOGEN Module

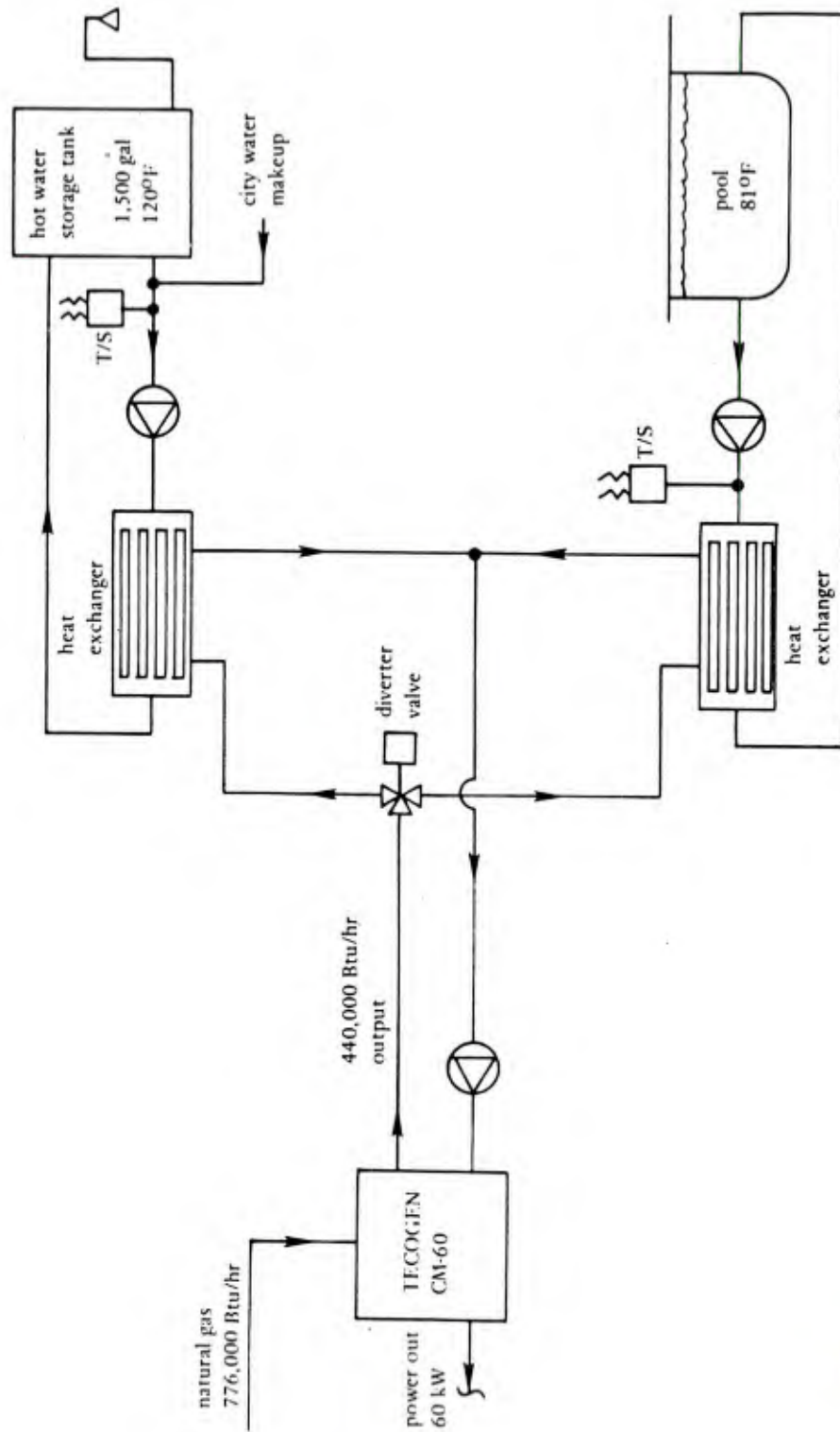

Figure 3. Simplified Diagram of Cogeneration System at Building 261, NS, Treasure Island, SF

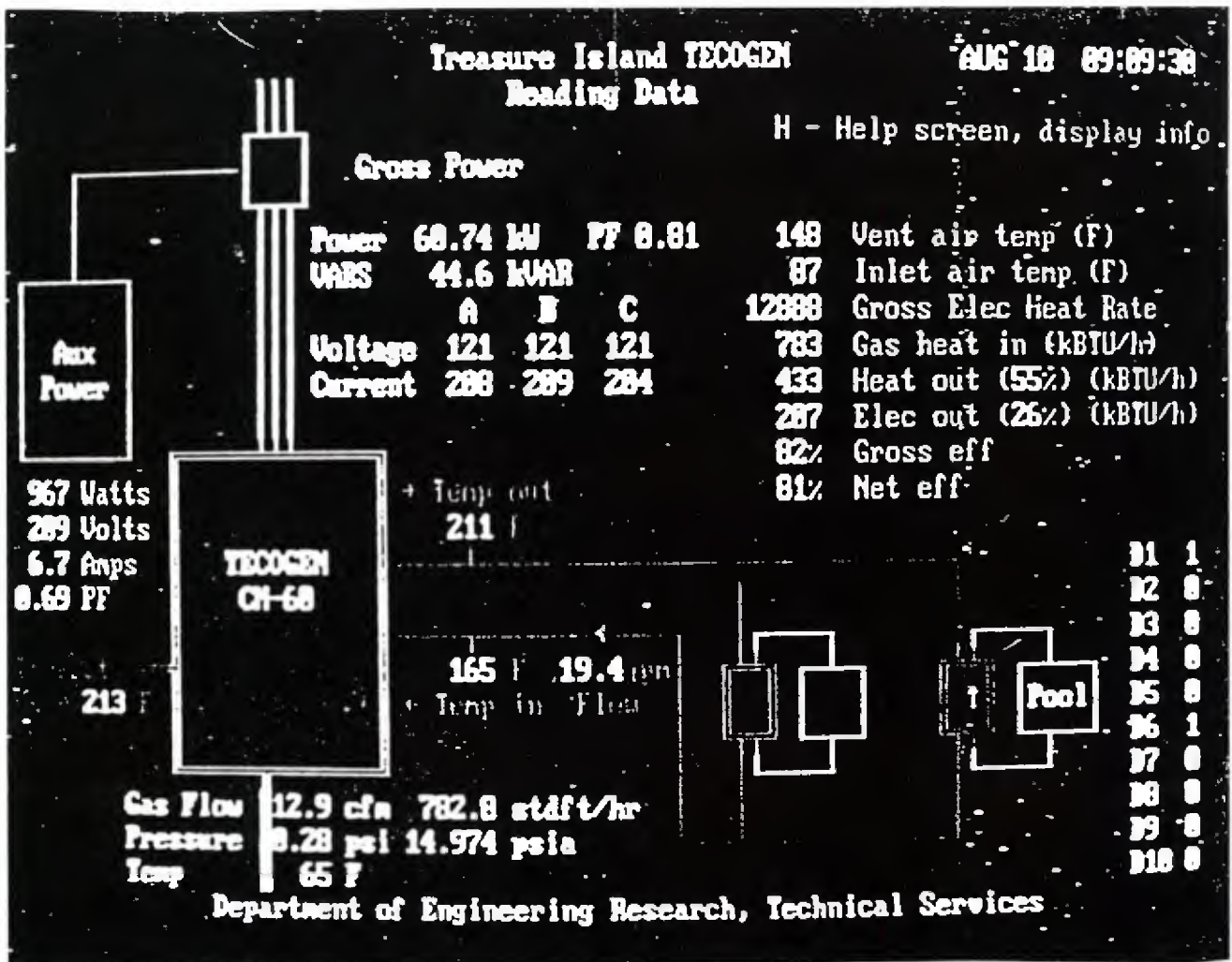

Figure 4. Display of the TECOGEN Operational Data Monitored on the Computer Screen.

TREASURE ISLAND TECOGEN Average Energy Distribution

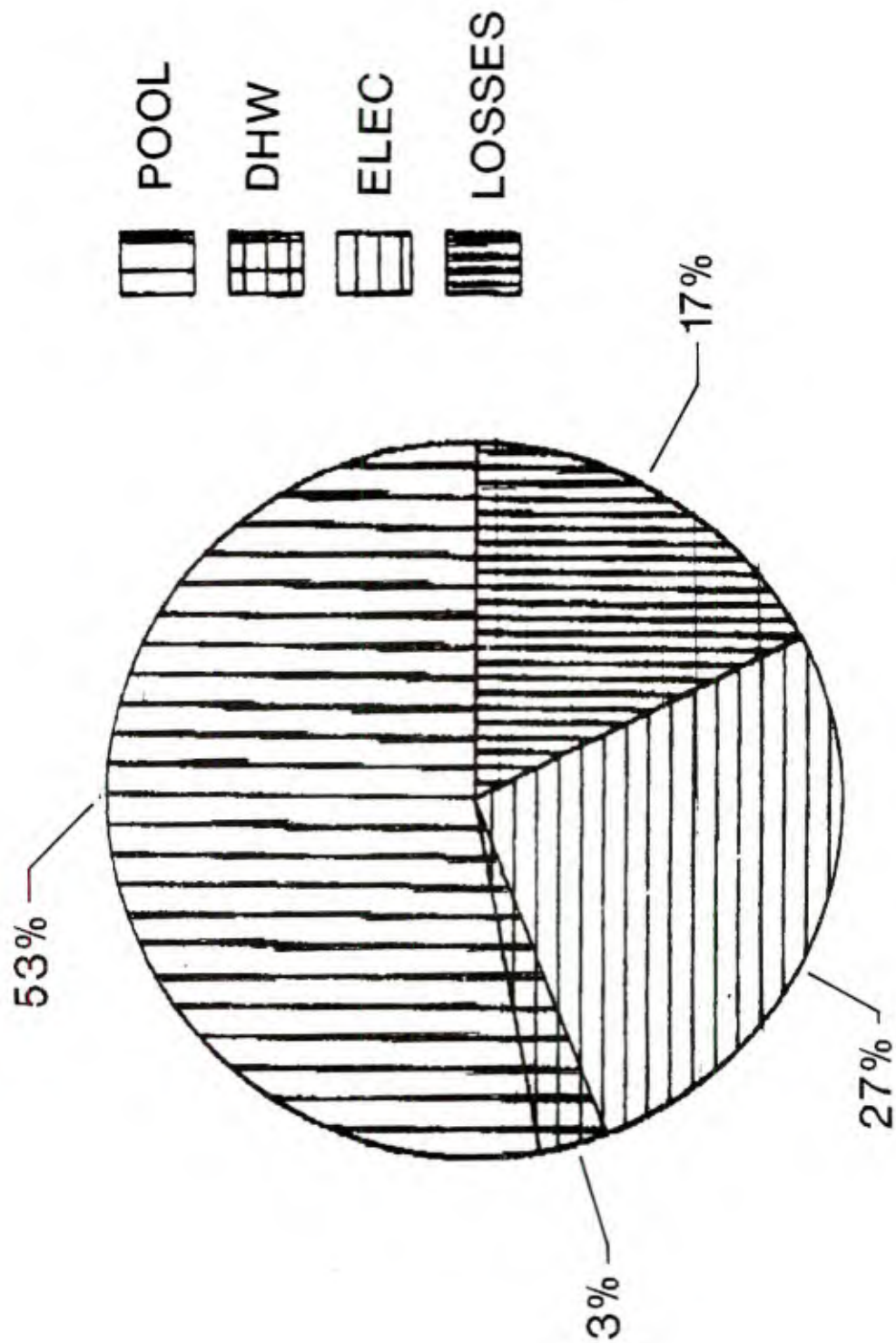

Figure 5. Average Energy Distribution from the TECOGEN

TREASURE ISLAND TECOGEN Thermal Output

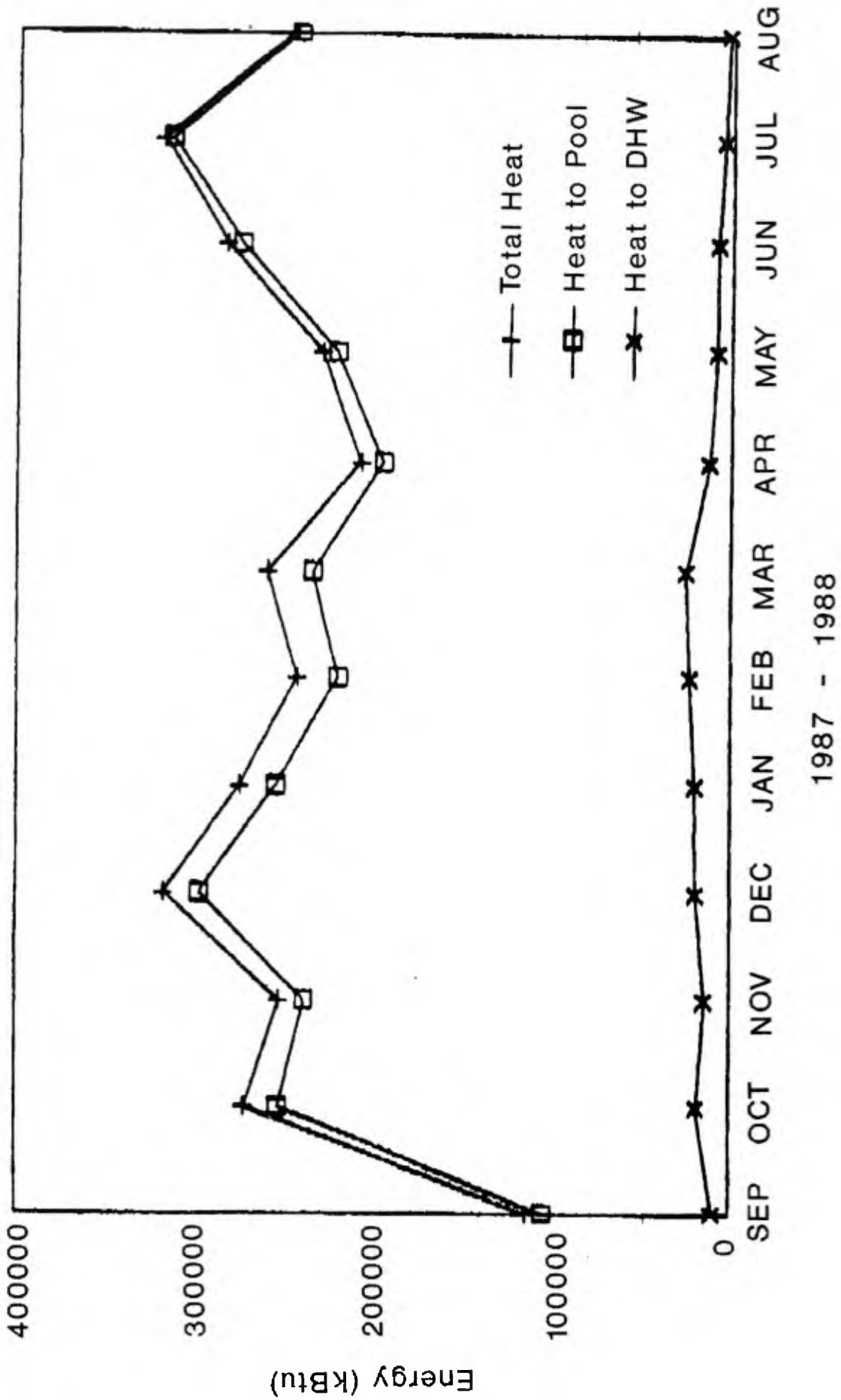
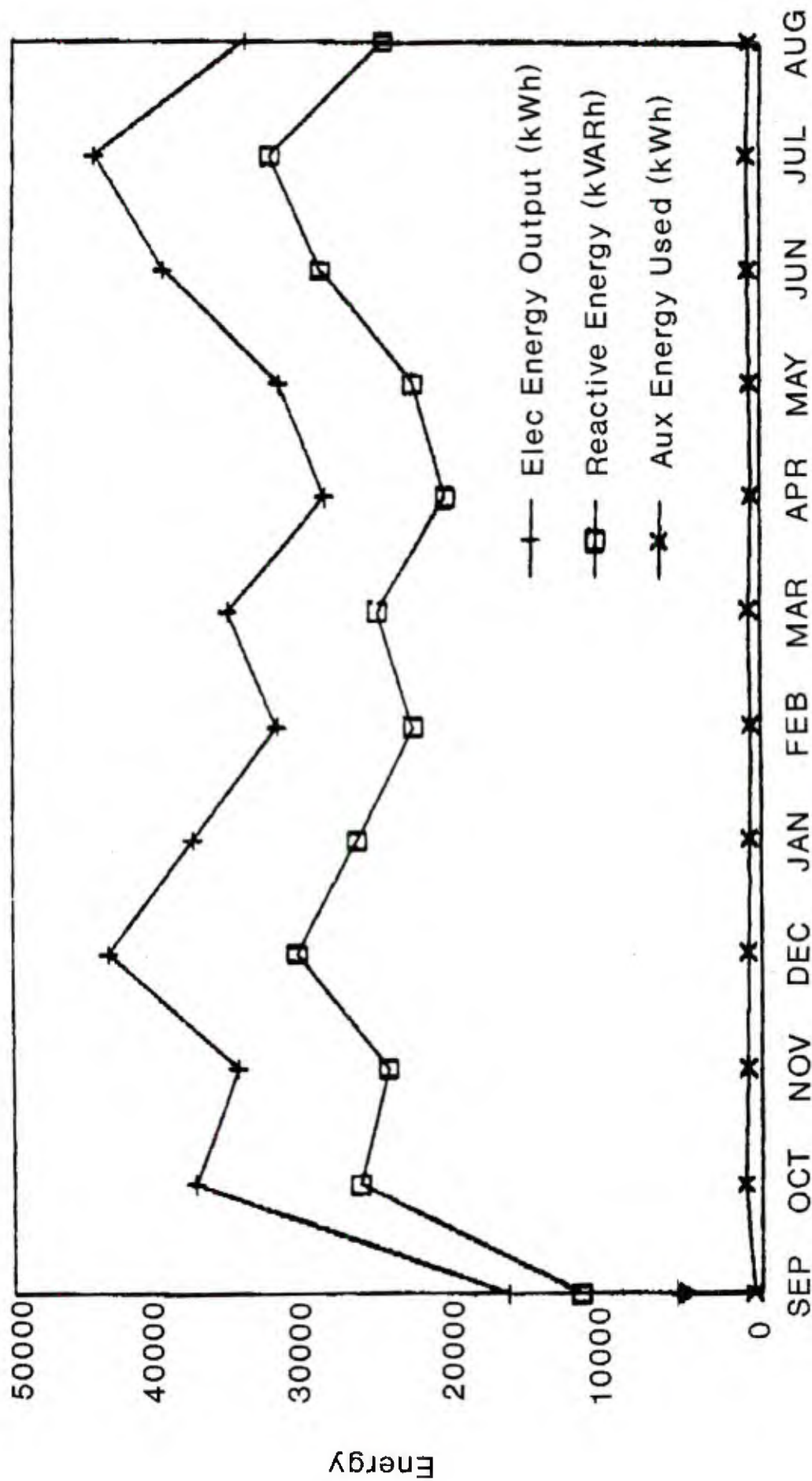

Figure 6. Monthly Thermal Output from the TECOGEN

TREASURE ISLAND TECOGEN Electrical



1987 - 1988

Figure 7. Monthly Electric Output from the TECOGEN

TREASURE ISLAND TECOGEN System

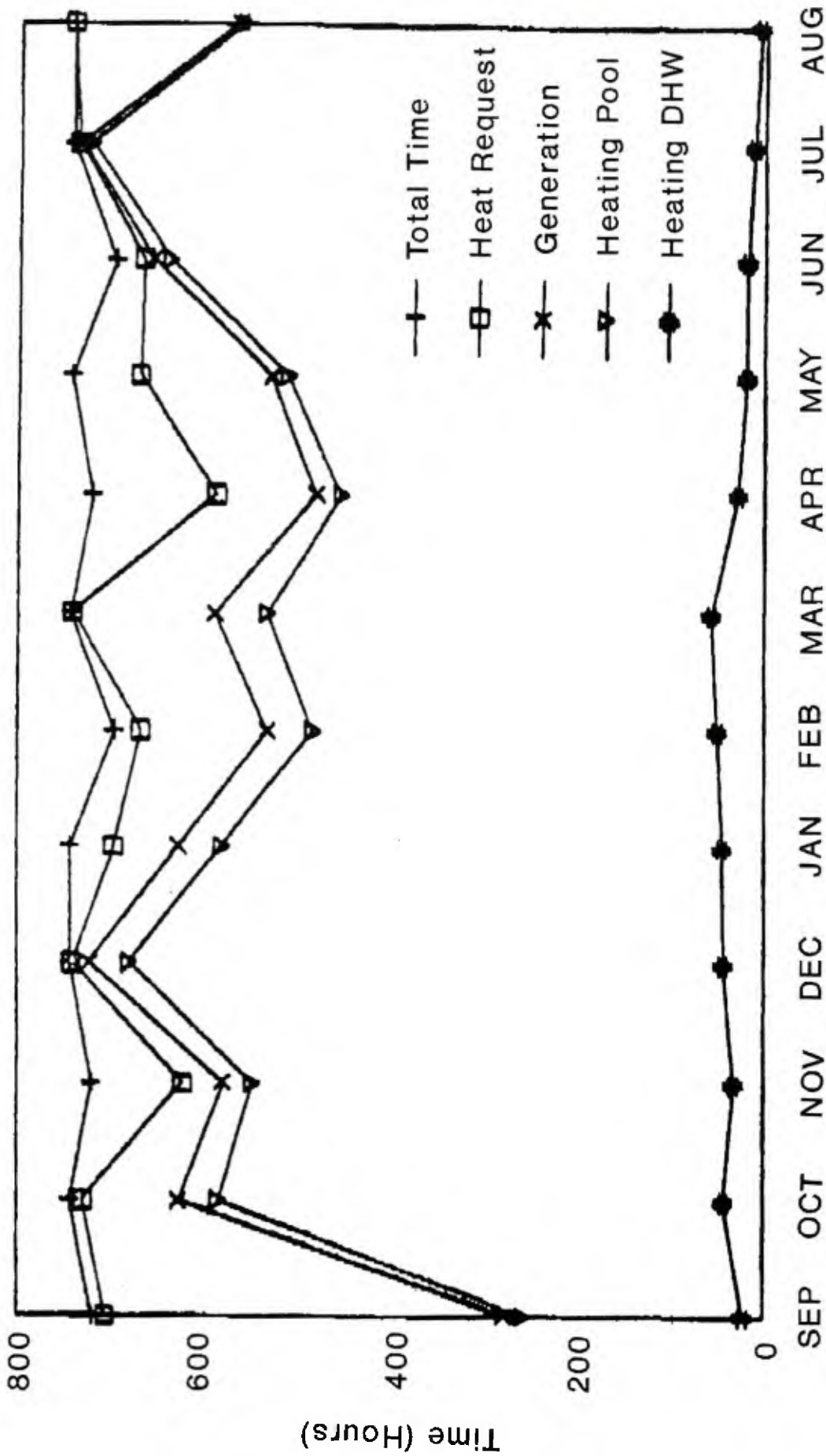

1987 - 1988

Figure 8. Monthly Operating Hours of the TECOGEN

Treasure Island Cogeneration Project

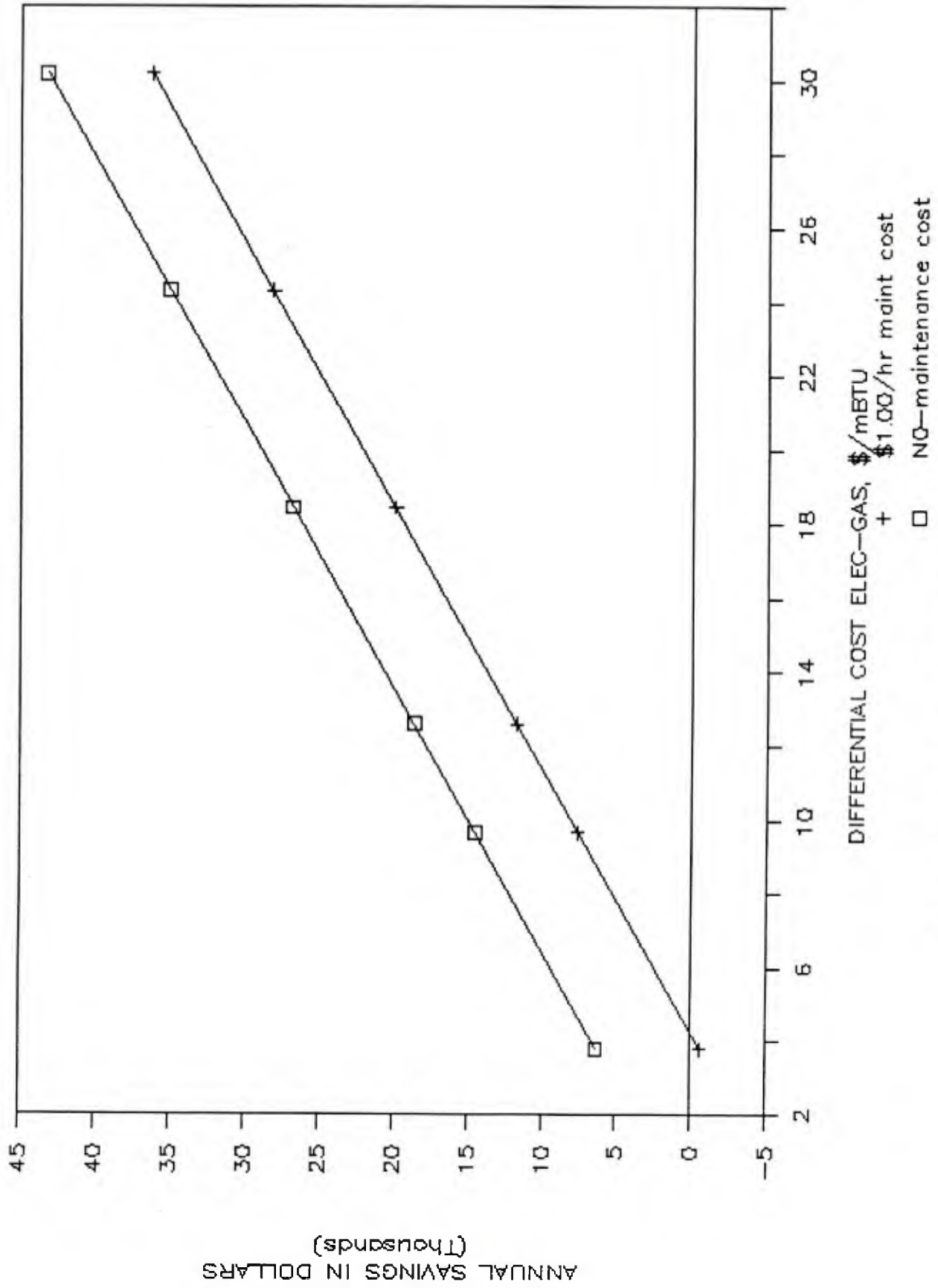

Figure 9. Annual Savings in Energy Costs

| | Sep 1987 | Oct | Nov | Dec | Jan 1988 | Feb | Mar | Apr | May | Jun | Jul | Aug |
|--------------------------------|----------|--------|--------|--------|----------|--------|--------|--------|--------|--------|--------|--------|
| GAS | | | | | | | | | | | | |
| Gas use (ft ³) | 208786 | 480925 | 436150 | 540386 | 468933 | 407129 | 449656 | 370394 | 412335 | 511804 | 575722 | 442778 |
| Gas use (Std ft ³) | 211666 | 485667 | 447028 | 550775 | 478343 | 415324 | 458273 | 376477 | 417828 | 516905 | 581040 | 445764 |
| Gas heating value (kBtu) | 211666 | 489667 | 447028 | 550775 | 478343 | 415324 | 458273 | 376477 | 417828 | 516905 | 581040 | 445764 |
| Average gas use rate (Btu/h) | 760494 | 781467 | 772120 | 762248 | 763148 | 780896 | 778648 | 782733 | 790524 | 787608 | 789789 | 787913 |
| THERMAL | | | | | | | | | | | | |
| Time heating pool (h) | 258.1 | 584.4 | 547.6 | 680.4 | 581.2 | 484.0 | 532.0 | 453.7 | 510.9 | 637.8 | 724.4 | 559.7 |
| Time heating DHW (h) | 22.0 | 42.7 | 32.6 | 44.1 | 45.6 | 50.7 | 57.5 | 28.7 | 19.8 | 19.5 | 11.6 | 6.3 |
| Heat delivered to pool (kBtu) | 103979 | 253505 | 238823 | 297542 | 254780 | 219867 | 234246 | 195216 | 221087 | 275080 | 314617 | 243297 |
| Heat delivered to DHW (kBtu) | 9520 | 18414 | 14202 | 19500 | 19991 | 23033 | 25316 | 12521 | 8253 | 8369 | 4959 | 2683 |
| Total heat output (kBtu) | 113499 | 271919 | 253025 | 317041 | 274772 | 242901 | 259563 | 207737 | 229340 | 283449 | 319577 | 245980 |
| Average thermal rate (Btu/h) | 407792 | 433959 | 437031 | 438771 | 438370 | 456705 | 441020 | 431906 | 433909 | 431891 | 434380 | 434784 |
| Thermal efficiency (%) | 54. | 56 | 57 | 58 | 57 | 58 | 57 | 55 | 55 | 55 | 55 | 55 |
| ELECTRICAL | | | | | | | | | | | | |
| Gross energy output (kWh) | 16957 | 37849 | 34970 | 43660 | 37967 | 32328 | 35604 | 29122 | 32181 | 39911 | 44590 | 34459 |
| Reactive energy input (kVARh) | 12063 | 26908 | 24979 | 31072 | 27048 | 23272 | 25645 | 21006 | 23207 | 29372 | 32736 | 25239 |
| Unit power factor | .82 | .82 | .82 | .82 | .82 | .82 | .82 | .82 | .82 | .82 | .82 | .82 |
| Auxiliary energy used (kWh) | 536 | 1114 | 929 | 912 | 812 | 755 | 810 | 621 | 722 | 830 | 914 | 772 |
| Average power (kW) | 60.9 | 60.4 | 60.4 | 60.4 | 60.6 | 60.8 | 60.5 | 60.5 | 60.9 | 60.8 | 60.6 | 60.9 |
| Electrical efficiency (%) | 27 | 26 | 27 | 27 | 27 | 27 | 27 | 26 | 26 | 26 | 26 | 26 |
| SYSTEM | | | | | | | | | | | | |
| Total time in month (h) | 720 | 744 | 720 | 744 | 744 | 696 | 744 | 720 | 744 | 696 | 744 | 744 |
| Available time (h) | 292.3 | 640.7 | 676.7 | 724.1 | 673.8 | 599.4 | 590.8 | 613.8 | 602.1 | 685.7 | 741.7 | 565.8 |
| Generation time (h) | 278.3 | 626.6 | 579.0 | 722.6 | 626.8 | 531.9 | 588.5 | 481.0 | 528.5 | 656.3 | 755.7 | 565.8 |
| Thermal request for heat (h) | 706.0 | 729.9 | 622.3 | 742.5 | 697.0 | 668.5 | 741.7 | 587.2 | 670.4 | 666.6 | 758.0 | 743.9 |
| Non generation time (h) | 441.7 | 117.4 | 141.0 | 21.4 | 117.2 | 164.1 | 155.5 | 239.0 | 215.5 | 39.7 | 8.3 | 178.2 |
| Gross efficiency (%) | 81 | 82 | 83 | 85 | 85 | 85 | 83 | 82 | 81 | 81 | 81 | 82 |
| Net efficiency (%) | 80 | 81 | 83 | 84 | 84 | 84 | 83 | 81 | 81 | 81 | 81 | 81 |
| Gross elec heat rate (Btu/kWh) | 12482 | 12937 | 12783 | 12615 | 12599 | 12847 | 12871 | 12927 | 12983 | 12951 | 13031 | 12936 |
| Net elec heat rate (Btu/kWh) | 12890 | 13330 | 13132 | 12884 | 12874 | 13146 | 13171 | 13209 | 13281 | 13227 | 13303 | 13253 |
| Availability factor (%) | 41 | 86 | 94 | 97 | 91 | 80 | 79 | 85 | 81 | 99 | 100 | 76 |
| Operating factor (%) | 39 | 84 | 80 | 97 | 84 | 76 | 79 | 67 | 71 | 94 | 99 | 76 |
| Utilization factor (%) | 95 | 98 | 86 | 100 | 93 | 95 | 100 | 78 | 88 | 96 | 99 | 100 |

Table 1. TECOGEN Operational Data from September 1987 to August 1988

Table 2. Cost Benefits from the Operation of TECOGEN

| | | | |
|----------------------------|----------------------------|---------|-------|
| Fuel cost for cogen | \$/MBtu | 5 | |
| Fuel cost for boiler | \$/MBtu | 5 | |
| Cost of teco elect to Navy | \$/kWh | 0 | |
| Cost of grid elect to Navy | \$/kWh | 0.05 | |
| Cost of shelter and surv. | \$/year | 0 | |
| | | | |
| Total hours of operation | hrs/year | 6921 | |
| Net kWh produced | kWh/year | 409897 | |
| Net thermal output | MBtu/year | 3019 | |
| Fuel consumption of TECO | kBtu/hr | 778.1 | |
| Calculations | | | |
| 1. | Value of elect to Navy | \$/year | 20495 |
| 2. | Value of heat to Navy | \$/year | 20965 |
| 3. | Cost of elect from TECO | \$/year | 0 |
| 4. | Cost of fuel for TECO | \$/year | 26928 |
| 5. | Revenue from shelter & sur | \$/year | 0 |
| | | | |
| | Net Annual benefit to Navy | \$/year | 14532 |

APPENDIX A

Equations for the Calculation of Energy Balance

Thermal Energy:

The thermal output energy is calculated based on the fluid, flow rate, and temperature drop at the terminals of the cogeneration module. The thermal energy Q_T is:

$$Q_T = M \times C_p \times (T_{OUT} - T_{IN}) \quad (\text{BTU/h})$$

where M = Fluid mass flow rate (lb/h)
 C_p = Fluid specific heat (BTU/lb-F)
 T_{OUT} = Fluid temp. out of Tecogen (F)
 T_{IN} = Fluid temp. into Tecogen (F)

The fluid mass flow rate is calculated as follows:

$$M = P \times F \times C \quad (\text{lb/h})$$

where P = Fluid density (lb/ft³)
 F = Fluid flow rate (gal/min)
 C = Constant, 60 (min/hr)/7.481 (gal/ft³)

Gathering terms and inputting constants for water as the fluid:

$$Q_T = 8.0208 \times \{62.59596 + T_{IN} \times [2.2714 \times 10^{-4} - 6.35 \times 10^{-5} \times (T_{IN})]\} \\ \times \text{Flow} \times (T_{OUT} - T_{IN}) \quad (\text{BTU/h})$$

The water temperature in and out, and flow rate are measured, and entered into the above equation to determine the thermal output energy.

Gas Energy Input:

The Input energy supplied by natural gas is calculated based on the gas flow rate. The gas energy, Q_G is:

$$Q_G = M \times PCF \times TCF \times HV \times C \quad (\text{BTU/h})$$

where M = Measured flow rate (ft³/min)
 PCF = Pressure correction factor, (gas pressure/ standard pressure)
 TCF = Temperature correction factor, (standard temp/gas temp)
 HV = Heating value of the gas (BTU/ft³)
 C = Constant, 60 (min/h)

The heating value of the gas was determined by gas chromatography. The DER Source Test Unit performed this test and found a value of 1004 BTU/ft³.

Gathering terms and inputing constants, the gas input energy becomes:

$$Q_G = M \times (P_{\text{gas}}/14.696) \times \frac{459.67}{T_{\text{gas}}} \times 1004 \times 60 \quad (\text{BTU/h})$$

Electrical Output Energy:

The electrical output energy is calculated based on the output of a three phase power transducer. The electric energy, Q_E is:

$$Q_E = V_T/R \times A \times \text{CTR} \times \text{ACF} \times \text{RCF} \times \text{PCF} \times C \quad (\text{BTU/h})$$

- where V_T = Output voltage of transducer across load resistor R (V)
 R = Load resistance (ohms)
 A = Transducer full scale input/output (1500 watts/.001 amps)
 CTR = Current transformer (CT) nominal ratio, 250/5
 ACF = CT phase correction factor
 RCF = CT ratio correction factor
 PCF = Potential correction factor
 C = Constant, 3.413 (BTU/h / W)

The current transformer (CT) ratio correction factor (RCF) is the actual CT ratio divided by the nominal ratio of 250/5. The RCF is a function of the current through the CT. The corrections for individual phases are applied to the current transducers. The average of the ratio corrections is applied to the watt/watthour and var/varhour transducers. The ratio corrections are obtained in the DER standards laboratory, (see appendix 2), and shown below.

$$\begin{aligned} \text{RCF}_A &= 0.9979 - 4.446 \times 10^{-5} \times I_A + 9.968 \times 10^{-8} \times I_A^2 \\ \text{RCF}_B &= 1.0000 - 5.465 \times 10^{-5} \times I_B + 1.140 \times 10^{-7} \times I_B^2 \\ \text{RCF}_C &= 0.9999 - 6.076 \times 10^{-5} \times I_C + 1.312 \times 10^{-7} \times I_C^2 \\ \text{RCF} &= (\text{RCF}_A + \text{RCF}_B + \text{RCF}_C)/3 \end{aligned}$$

The CT phase angle correction factor (ACF) corrects for the phase shift made by the CT. The ACF is calculated by using the apparent phase angle, the CT phase angle shift, and the power factor (pf). The CT phase angle shift is obtained from the DER standards laboratory calibration and dependent upon the current. The calculations for phase shift (BETA) and ACF are shown below in radians.

$$\begin{aligned} \text{BETA}_A &= (\text{PI}/180) \times (28.09 - .0917 \times I_A + 1.343 \times 10^{-4} \times I_A^2) / 60 \\ \text{BETA}_B &= (\text{PI}/180) \times (28.09 - .0917 \times I_B + 1.343 \times 10^{-4} \times I_B^2) / 60 \\ \text{BETA}_C &= (\text{PI}/180) \times (31.24 - .1296 \times I_C + 2.136 \times 10^{-4} \times I_C^2) / 60 \end{aligned}$$

$$\text{ANGLE} = (\text{PI}/2) - \text{TAN}^{-1}[(\text{pf})/(1-\text{pf}^2)^{-1/2}]$$

$$\begin{aligned} \text{ACF}_A &= \cos(\text{ANGLE} + \text{BETA}_A) / \text{pf} \\ \text{ACF}_B &= \cos(\text{ANGLE} + \text{BETA}_B) / \text{pf} \\ \text{ACF}_C &= \cos(\text{ANGLE} + \text{BETA}_C) / \text{pf} \\ \text{ACF} &= (\text{ACF}_A + \text{ACF}_B + \text{ACF}_C)/3 \end{aligned}$$

The corrected phase current becomes :

$$\begin{aligned} I_A &= I_A \times RCF_A \times ACF_A \\ I_B &= I_B \times RCF_B \times ACF_B \\ I_C &= I_C \times RCF_C \times ACF_C \end{aligned}$$

The potential correction factor (PCF) corrects the voltage reading from the point where it was measured to the generator terminals. The change in voltage is a function of the Tecogen phase current, wire size, and burden of the instrumentation. The corrected phase current is used and the voltage drop in each phase and the PCF are calculated as shown below :

$$\begin{aligned} V_A \text{ drop} &= I_A \times 0.00168 \\ V_B \text{ drop} &= I_B \times 0.00168 \\ V_C \text{ drop} &= I_C \times 0.00168 \end{aligned}$$

$$PCF_A = (V_A + V_A \text{ drop})/V_A \quad PCF_B = (V_B + V_B \text{ drop})/V_B \quad PCF_C = (V_C + V_C \text{ drop})/V_C$$

$$PCF = (PCF_A + PCF_B + PCF_C)/3$$

The corrected phase to neutral voltage becomes :

$$\begin{aligned} V_A &= V_A \times PCF_A \\ V_B &= V_B \times PCF_B \\ V_C &= V_C \times PCF_C \end{aligned}$$

Parasitic Electrical Energy:

The parasitic electrical energy is the energy required to operate the three water circulating pumps and associated equipment. The power is calculated based on the output of a single phase power transducer. The parasitic electric energy, Q_p is:

$$Q_p = V_T/R \times A \times PT \times C \quad (\text{BTU/h})$$

where V_T = Output voltage of transducer across load resistor R (V)
 R = Load resistance (ohms)
 A = Transducer full scale input/output (500 watts/.001 amps)
 PT = Potential transformer ratio (3.6)
 C = Constant, 3.413 (BTU/h / W)

Efficiency:

The gross efficiency of the unit is the ratio of the total thermal and electrical energy to the gas energy supplied. The net efficiency subtracts the parasitic electrical energy from the gross electric energy.

$$\text{Gross Efficiency} = (Q_T + Q_E)/Q_G$$

$$\text{Net Efficiency} = (Q_T + Q_E - Q_P)/Q_G$$

APPENDIX B

System Performance Parameters

GAS

| | | |
|----------------------|------------------------------|--|
| Gas use | (ft ³ x 1000) | The amount of gas used by the machine in thousands of cubic feet. |
| Gas use | (Std ft ³ x 1000) | The amount of gas used by the machine corrected to standard temperature and pressure conditions. |
| Gas heating value | (kBTU) | The heating value for the gas is approximated by multiplying the standard cubic feet of gas by 1000. |
| Average gas use rate | (BTU/h) | Average use rate for the month. |

THERMAL

| | | |
|------------------------|---------|---|
| Time heating pool | (h) | The total time in hours the machine's thermal output was directed to the swimming pool. |
| Time heating DHW | (h) | The total time in hours the machine's thermal output was directed to the domestic hot water (DHW) tank. |
| Heat delivered to pool | (kBTU) | Thermal energy delivered to the pool. |
| Heat delivered to DHW | (kBTU) | Thermal energy delivered to the DHW tank. |
| Total heat output | (kBTU) | Total thermal output, (pool + DHW) |
| Average thermal rate | (BTU/h) | Total thermal output / Generation time |
| Thermal efficiency | (%) | Total thermal output / Gas energy input |

ELECTRICAL

| | | |
|-----------------------|---------|---|
| Gross energy output | (kWh) | Electrical energy output at the terminals of the machine. |
| Reactive energy input | (kVARh) | Reactive energy input at the terminals of the machine. |
| Unit power factor | | Average power factor for the month. |
| Auxiliary energy used | (kWh) | Energy used by the three pumps in the thermal heat exchange system. |
| Average power | (kW) | Gross energy output / Generation time |
| Electrical efficiency | (%) | Gross energy output / Gas energy input |

SYSTEM

| | | |
|--------------------------|-----------|---|
| Total time in month | (h) | Total number of hours in the month |
| Available time | (h) | (Total time - (request for heat time - generation time)) |
| Generation time | (h) | Time the machine was producing heat and power. |
| Thermal request for heat | (h) | Time the thermal sensors in the pool or DHW tank were requesting heat. |
| Non generation time | (h) | Total time in month - Generation time |
| Gross efficiency | (%) | (Thermal output + Electrical output) / Gas energy input |
| Net efficiency | (%) | (Thermal output + Electrical output - Auxiliary input) / Gas energy input |
| Gross electric heat rate | (BTU/kWh) | Gas energy input / Gross Electric Energy output |
| Net electric heat rate | (BTU/kWh) | Gas energy input / (Gross Electric energy - Auxiliary electric energy) |
| Availability factor | (%) | Available time / Total time in month |
| Operating factor | (%) | Generation time / Total time in month |
| Utilization factor | (%) | Generation time / available time |

Appendix C
DATA COLLECTION FORMS

Appendix C-1

Facility and Cogeneration Module Data Collection Form

ECONOMIC ASSESSMENT PROCEDURE FOR SMALL PACKAGED
COGENERATION SYSTEMS AT NAVAL ACTIVITIES

DATA COLLECTION FORM

1. Location: _____
2. Facility Number: _____
3. Facility Name: _____
4. Analysis Date: _____
5. Prepared by: _____
6. Number of Hours Per Day that the Facility is Operated _____
7. Facility Fuel Availability
 - Natural Gas _____
 - Diesel _____
 - Propane _____
8. Water Temperatures
 - Maximum hot water, deg-F _____
 - Minimum hot water, deg-F _____
 - Cold water, deg-F _____
9. Existing Thermal Storage Capacity, gal _____
10. Anticipated Annual Operating Hours _____
11. Energy Rates
 - Electrical Energy Cost, \$/KWH _____
 - Electrical Demand Cost, \$/KW _____
 - Thermal Fuel Cost, \$/MBtu _____
12. Thermal Efficiency for Existing Hot Water System, % _____
13. System Supplier _____
14. Cogeneration Module Thermal Output, KBtu/hr _____
15. Cogeneration Module Electric Output, KW _____

Note: If the electric output is not available use the following equation to estimate this value:

$$\text{Electric Output} = 0.19 * \text{Thermal Output}$$

16. Cogeneration Module Maintenance Factor, % _____

Note: This value represents the percent down time due to

maintenance of the PCS unit.

17. Cogeneration Module Fuel Type Fuel Rate
 Natural Gas ___ ___ cuft/hr
 Diesel Fuel ___ ___ gal/hr
 Propane ___ ___ gal/hr

18. Cogeneration Module Generator Type
 Synchronous ___
 Induction ___

19. Equipment Purchase Price, \$ _____

Note: If actual purchase price information is not available use the following equation to estimate the value:

Equipment Purchase Price = 1500 * Electric Output

20. Installation Cost, \$ _____

21. Cogeneration Module Fuel Cost, \$/MBtu _____

22. Additional Storage Cost, \$ _____

23. Cogeneration Module Maintenance Cost, \$/KWH _____

Note: If cogeneration module maintenance cost data are not available, an average value of \$0.015/KWH can be used.

24. Economic Factors

Economic Life, years _____
Discount Rate, % _____

Uniform Present Worth (UPW) Discount Factor for Economic Life (N) and Discount Rate (R)

UPW(N,R) _____

Uniform Present Worth (UPW) Discount Factors for Economic Life (N) and Discount Rate (R) Adjusted for Electric and Fuel Price Escalation

UPW(N,R) fuel _____
UPW(N,R) electric _____

Note: The values for economic life and discount rate for a PCS unit are found in NAVFAC P-442, the Economic Analysis Handbook. Current guidelines recommend using a value of 25 years for the economic life (N = 25 years) and 7 percent for the discount rate (R = 7%). The Uniform Present Worth Discount Factor for these values can be calculated using the following equation:

$$UPW(N,R) = \frac{(1+R)^N - 1}{R(1+R)^N}$$

Therefore: $UPW(25,7) = 11.654$

Tables are also available for determining the uniform present worth discount factor. Refer to Principles of Engineering Economy, Grant, Ireson, and Leavenworth, Appendix D.

To estimate the values for the uniform present worth discount factor that has been adjusted for fuel and electric price escalation, refer to Appendices A, B, & C of the Methodology for Life Cycle Cost Analysis Using Average Fuel Costs, Department of Energy reference DOE/CE-0101.

If the fuel used for the PCS unit is natural gas, the discount rate is 7 percent ($R = 7\%$), and the useful life (or study period) is 25 years ($N = 25$), the uniform present worth discount factors adjusted for fuel price escalation are as follows:

$UPW(25,7)$ for natural gas = 21.23

$UPW(25,7)$ for electric = 12.26

* Note: The uniform present worth discount factors adjusted for fuel price escalation were obtained from the columns designated as "INDUSTRIAL" in DOE/CE-0101.

Appendix C-2

DHW Hourly Load Profile Data Collection Forms

DOMESTIC HOT WATER HOURLY LOAD PROFILES

Location: _____

Facility Number: _____

Facility Name: _____

Analysis Date: _____

Prepared by: _____

Weekdays (Monday-Friday)

Weekends (Saturday-Sunday)

| Hour | DHW (gal) |
|-----------|-----------|
| 2400-0100 | _____ |
| 0100-0200 | _____ |
| 0200-0300 | _____ |
| 0300-0400 | _____ |
| 0400-0500 | _____ |
| 0500-0600 | _____ |
| 0600-0700 | _____ |
| 0700-0800 | _____ |
| 0800-0900 | _____ |
| 0900-1000 | _____ |
| 1000-1100 | _____ |
| 1100-1200 | _____ |
| 1200-1300 | _____ |
| 1300-1400 | _____ |
| 1400-1500 | _____ |
| 1500-1600 | _____ |
| 1600-1700 | _____ |
| 1700-1800 | _____ |
| 1800-1900 | _____ |
| 1900-2000 | _____ |
| 2000-2100 | _____ |
| 2100-2200 | _____ |
| 2200-2300 | _____ |
| 2300-2400 | _____ |

| Hour | DHW (gal) |
|-----------|-----------|
| 2400-0100 | _____ |
| 0100-0200 | _____ |
| 0200-0300 | _____ |
| 0300-0400 | _____ |
| 0400-0500 | _____ |
| 0500-0600 | _____ |
| 0600-0700 | _____ |
| 0700-0800 | _____ |
| 0800-0900 | _____ |
| 0900-1000 | _____ |
| 1000-1100 | _____ |
| 1100-1200 | _____ |
| 1200-1300 | _____ |
| 1300-1400 | _____ |
| 1400-1500 | _____ |
| 1500-1600 | _____ |
| 1600-1700 | _____ |
| 1700-1800 | _____ |
| 1800-1900 | _____ |
| 1900-2000 | _____ |
| 2000-2100 | _____ |
| 2100-2200 | _____ |
| 2200-2300 | _____ |
| 2300-2400 | _____ |

Weekday Total _____

Weekend Total _____

Appendix D

CAMP PENDLETON PROCUREMENT SPECIFICATION

ACKNOWLEDGMENT OF AMENDMENTS

The offeror acknowledges receipt of amendments to the Solicitation for offers and related documents numbered and dated as follows:

| AMENDMENT NO | DATE | AMENDMENT NO 1 | DATE |
|--------------|------|----------------|------|
| | | | |
| | | | |

SECTION B - SUPPLIES/SERVICES AND PRICES

PART I - THE SCHEDULE

SECTION B - SUPPLIES/SERVICES/PRICES

| | <u>QTY</u> | <u>U/I</u> | <u>UNIT PRICE</u> | <u>TOTAL PRICE</u> |
|---|------------|------------|-------------------|--------------------|
| 1. Furnish and install, prepackaged, natural gas-engine driven, co-generation system at BEQ 1396-97-98 capable of supplying an average thermal usage of 182,000 BTU/hr for DHW heating. Cost to include all aspects of installation and start-up in accordance with specifications listed in Part I, Section C. Electrical energy to be delivered to Camp Pendleton grid. | 1 | SYS | _____ | _____ |

OFFEROR NOTE: A OFFER ON ITEM #1 MUST BE ACCOMPANIED BY AN OFFER ON ITEM #3.

Rated Thermal Delivery Rate

_____ BTU/hr.
(To be filled in by Contractor)

Rated Electrical Generator Capacity

_____ KW.
(To be filled in by Contractor)

Estimated Annual Availability

_____ hrs.
(To be filled in by Contractor)

Estimated PURPA Efficiency

_____ %.
(To be filled in by Contractor)
(Note: See Attachment #1 - Show calculations.)

ACKNOWLEDGMENT OF AMENDMENTS

The offeror acknowledges receipt of amendments to the Solicitation for offers and revised documents numbered and dated as follows:

| AMENDMENT NO | DATE | AMENDMENT NO | DATE |
|--------------|------|--------------|------|
| | | | |
| | | | |

SECTION B - SUPPLIES/SERVICES AND PRICES

PART I - CONT'D
SECTION B - CONT'D

QTY U/I UNIT PRICE TOTAL PRICE

- 2. Furnish and install, prepackaged, natural gas-engine driven, co-generation system at Mess Hall 13100, capable of supplying an average thermal usage rate of 120,000 BTU/hr for DHW heating. Cost to include all aspects of installation and start-up in accordance with specifications listed in Part I, Section C. Electrical energy to be delivered to Camp Pendleton grid.

1 SYS _____

OFFEROR NOTE: A OFFER ON ITEM #2 MUST BE ACCOMPANIED BY AN OFFER ON ITEM #4.

Rated Thermal Delivery Rate

_____ BTU/hr.
(To be filled in by Contractor)

Rated Electrical Generator Capacity

_____ KW.
(To be filled in by Contractor)

Estimated Annual Availability

_____ hrs.
(To be filled in by Contractor)

Estimated PURPA Efficiency

_____ %.
(To be filled in by Contractor)
(Note: See Attachment #1 - Show calculations.)

| ACKNOWLEDGMENT OF AMENDMENTS The offeror acknowledges receipt of amendments to the Solicitation for offers and revised documents numbered and dated as follows: | AMENDMENT NO | DATE | AMENDMENT NO | DATE |
|--|--------------|------|--------------|------|
| | | | | |
| | | | | |

SECTION B - SUPPLIES/SERVICES AND PRICES

PART I - CONT'D
SECTION B - CONT'D

| | <u>QTY</u> | <u>U/I</u> | <u>UNIT PRICE</u> | <u>TOTAL PRICE</u> |
|---|------------|------------|-------------------|--------------------|
| 3. Maintenance coverage to operate and maintain unit described in <u>Item #1</u> . | 1 | YR | | |
| Guarantee systems performance for _____ hrs/year at a capacity (Contractor to fill in) of _____ KW for five (5) years (Contractor to fill in) | | | | |
| DELIVERY OF LESS THAN THE GUARANTEED KW-HR ENERGY SHALL RESULT IN A CHARGE BEING ASSESSED THE CONTRACTOR OF \$ _____ ANNUALLY FOR EACH KW-HR LESS THAN THAT GUARANTEED. If the number of annual co-generation system operational hours is reduced because of needs of the government, the amount of guaranteed energy delivered (KW-HR) shall be reduced proportionately. | | | | |
| 4. Maintenance coverage to operate and maintain unit described in <u>Item #2</u> . | 1 | YR | | |
| Guarantee systems performance for _____ hrs/year at a capacity (Contractor to fill in) of _____ KW for five (5) years (Contractor to fill in) | | | | |
| DELIVERY OF LESS THAN THE GUARANTEED KW-HR ENERGY SHALL RESULT IN A CHARGE BEING ASSESSED THE CONTRACTOR OF \$ _____ ANNUALLY FOR EACH KW-HR LESS THAN THAT GUARANTEED. If the number of annual co-generation system operational hours is reduced because of needs of the government, the amount of guaranteed energy delivered (KW-HR) shall be reduced proportionately. | | | | |

PART I - CONT'DSECTION C - DESCRIPTIONS/SPECIFICATIONSPROJECT DESCRIPTION

THIS IS A REQUEST FOR PROPOSAL (RFP) FOR THE SUPPLY, INSTALLATION, AND OPERATION AND MAINTENANCE OF TWO (2) PREPACKAGED, CO-GENERATION SYSTEMS WHICH UTILIZE NATURAL GAS FUEL. THESE UNITS ARE FOR A PROJECT TO DEMONSTRATE THE APPLICABILITY OF SMALL CO-GENERATION SYSTEMS AT U.S. NAVY/MARINE CORPS BASES. SEPARATE AWARDS (CONTRACTS) WILL BE ISSUED TO COVER: (1) SUPPLY AND INSTALLATION; (2) OPERATION AND MAINTENANCE OF THE CO-GENERATION SYSTEMS.

CO-GENERATION SYSTEM REQUIREMENTS

- (a) The prospective contractor shall size the co-generation systems (co-generation unit and associated equipment) offered to meet the below listed requirements:
- (1) Meet the site thermal requirements (See pages 13 through 14, "Thermal Usage Data for Co-generation Sites").
 - (2) Meet PURPA requirements for co-generators (See Attachment 1 - "Calculation OF PURPA Efficiency").
 - (3) Maximize annual government savings and minimize payback (See Attachment #2 - "Calculation of Annual Government Savings and Payback").
- (b) The contractor shall show that his proposed system design meets the requirement of the above paragraph. Contractor shall be responsible for the installation and operation of all equipment (e.g. additional hot water storage tanks, if required) required to deliver the stated thermal and electrical delivery rates for his equipment.
- (c) The prime-mover shall be a natural-gas-fired internal combustion engine.
- (d) Electrical generator shall be induction type.
- (e) Thermal energy generated will be used at each individual site for the production of domestic hot water.
- (f) Electrical power generated at each site will be fed to the Camp Pendleton electrical grid as 3 phase, 220 volt, 60 hertz power.
- (g) Equipment installed must operate in conjunction with currently installed equipment (e.g. water heater, boiler, hot water storage tanks). Contractor shall be responsible for installing and maintaining required interface controls and equipment, and for ensuring compatible operation between equipment already in place and that installed by the contractor. Marine Corps Base, Camp Pendleton shall remain responsible for operating and maintaining that equipment now installed.

PART I - CONT'D
SECTION C - CONT'D

- (h) Control system shall provide automatic interfacing to the Camp Pendleton electrical grid when the generated voltage is of the appropriate amplitude, phase angle, and frequency. The Controls shall permit unattended operation with automatic starting, stopping, connecting, and disconnecting when desired. The controls shall incorporate a manual control for shutting down the unit to allow for system maintenance and repair.
- (i) Each co-generation system will operate in series (as preheater) with existing thermal systems and in parallel with the existing electrical system. Appropriate valving switches and controls must be installed so that any failure of the co-generation unit will not cause interruption of the delivery of either thermal or electrical energy to the site in question.
- (j) Contractor shall provide one (1) to five (5) dry contact switches (the number to be determined by the government, dependent upon the characteristics of the particular co-generation system selected) which will be required to provide system status information.
- (k) Contractor shall install and maintain meters in operating, calibrated condition for monitoring the performance and output of the co-generation plants. The installation, maintenance, and calibration of all meters shall be at the contractor's expense.
- (1) A natural gas meter to measure the cubic feet of natural gas fed to the co-generation engine in a given length of time.
 - (2) Necessary meters such as flowmeters, thermometers, or pressure gauges mounted on the module's entering and leaving hot water pipes to measure the thermal energy delivered for DHW use in a given length of time.
 - (3) All electrical service furnished by the co-generation system shall be measured by metering equipment furnished, installed, maintained and calibrated by the contractor at his expense. Contractor shall interface with San Diego Gas & Electric (SDG&E), providing all drawings, specifications, and hardware required for system permits, testing, start-up and operation as required by Rule 21 or other requirements of SDG&E.
 - (4) Contractor shall provide signals which indicate the following measured and calculated quantities for each co-generation system installed at Marine Corps Base, Camp Pendleton. Signals shall be provided in a form such that they can be connected directly to a modem unit for transmission to remote monitoring sites. Contractor shall ensure that these signals remain available throughout the length of the contract.

PART I - CONT'D
SECTION C - CONT'D

VARIABLES METERED TO BE AS FOLLOWS:

- a. Gross KW of power being delivered at the generator terminals at any instant
- b. Voltage of each phase of electrical power
- c. Current of each phase of electrical power
- d. Parasite electrical power consumed
- e. Engine speed in RPM
- f. Temperature of water leaving cogen unit in °F
- g. Temperature of water returning to cogen unit in °F
- h. Water flow rate
- i. Natural gas flow rate
- j. Status of any co-generation system alarms
- k. Cumulative hours of operation

CALCULATED PARAMETERS TO BE AS FOLLOWS:

- a. Cumulative electric energy delivered
- b. Cumulative thermal energy delivered
- c. Cumulative parasite energy consumed
- d. Cumulative power factor
- e. Cumulative Thermal efficiency
- f. Cumulative Electric efficiency
- g. Cumulative System efficiency
- h. System Availability Factor

CO-GENERATION SYSTEM DESIGN

- (a) The Government shall review and approve drawings and specifications pertaining to the design of the facilities. Submission of the drawings and specifications for Government review and completion of review will be in accordance with the "Schedule" submitted by the Contractor and approved by the Government. The Government shall have the right to require modification to the designs for specified causes, namely; for safety of personnel; prevention of imminent harm to the environment; prevention of significant harm to property or equipment; meeting of minimum specifications; or jeopardy of Camp Pendleton mission.
- (b) Review by San Diego Gas & Electric Company. Electrical design, installation, and operation shall be in accordance with Rule 21 of SDG&E which has been approved by California P.U.C. Submission of drawings for SDG&E review and completion of review will be in accordance with the "Schedule" submitted by the contractor and approved by the Government. Contractor shall furnish, without additional cost to the Government, all electrical controls and protective apparatus and meters required by Rule 21 of SDG&E.

PART I - CONT'D
SECTION C - CONT'D

- (c) Design requirements: All areas should be in balance and reasonable for the purposes served, with equipment areas arranged and sized for efficient and functional use. Design shall conform to the following codes:
- (1) Uniform Building Code (latest edition) of the International Conference of Building Officials.
 - (2) Uniform Mechanical Code (latest edition) of the International Conference of Building Officials.
 - (3) National Electrical Code (latest edition).
 - (4) Uniform Plumbing Code (latest edition) of the International Association of Plumbing and Mechanical Officials.
 - (5) National Fire Codes (latest edition) of the National Fire Protection Association.
- (d) Structural requirements shall include installation of equipment and enclosures. Enclosures shall be in accordance with the prevailing architectural style at Building sites 13100 and 1397. Designs to be approved by Facilities Maintenance Officer.
- (e) Space is to be provided for (but not necessarily limited to):
- (1) Co-generation equipment operational areas
 - (2) Control areas
 - (3) Ancillary equipment areas
 - (4) Electrical power switching and paralleling equipment and associated equipment areas. To include telephone terminal board areas.
 - (5) Equipment service aisles shall be provided for access to all required equipment.
- (f) Each site, building 13100 and 1397 has an existing concrete pad measuring 8' x 8' for installation of co-generation systems.
- (g) Units will be installed outside, therefore contractor must ensure units are appropriately protected from the weather. Co-generation system design and installation must be such as to permit the installation of fencing (to be accomplished by the government).
- (h) Air intake system(s) shall include, as necessary, air inlet filter, air inlet silencer, connecting ducts and air cooler(s). All equipment shall comply with Uniform Mechanical, Building, Electrical, Plumbing and Fire Codes for the type of equipment installed.

PART I - CONT'D
SECTION C - CONT'D

- (i) Exhaust muffling/silencing equipment and emission control design and installation will meet or exceed all requirements of the Public Utilities Commission (PUC) of the State of California; Air Pollution Control District (APCD) of San Diego Areas; and Federal Environmental Protection Agency (EPA) requirements.

SCHEDULE AND CONSTRUCTION

- (a) The Contractor shall complete all design work, including any re-design, within forty-five (45) calendar days after award, exclusive of time for Government reviews. All construction work shall be completed and delivery of thermal electrical power to Camp Pendleton shall be initiated within one hundred-twenty (120) calendar days of award, inclusive of necessary reviews.
- (b) Within fifteen (15) calendar days after contract award, contractor shall submit a project schedule that shall include, but not limited to, the following points. "Schedule" is subject to approval by the Government.
- (1) Co-generation site development
 - (2) Permitting applied for
 - (3) Design initiated
 - (4) Design review by government and SDG&E
 - (5) Design completed
 - (6) Permitting completed
 - (7) Co-generation system PURPA qualifications
 - (8) Equipment orders placed
 - (9) Equipment delivered
 - (10) On-site construction initiated
 - (11) On-site construction completed
 - (12) Start up and acceptance testing
 - (13) System fully operational
 - (14) One (1) month operational report
 - (15) Six (6) month operational report
 - (16) Annual operational reports
- (c) The government will furnish, at no cost, such fresh water and electricity at existing outlets as may be required for construction work, in accordance with clause "Availability of Utility Services" NAVFAC 4-4330/5 (Rev. 1-70). Information concerning location of existing outlets may be obtained from the Facilities Maintenance Officer. Contractor shall carefully conserve utilities furnished. The Contractor, at his own expense, and in a manner satisfactory to the Contracting Officer, shall install and maintain all necessary temporary connections and distribution lines, and shall remove same within thirty (30) days of commencing thermal and electrical service.
- (d) Requests for permission to interrupt any station utility service during construction shall be submitted in writing to the Camp Pendleton Facilities Maintenance Officer, at a minimum, ten (10) working days prior to the desired date of interruption.

CONTINUATION SHEET

REFERENCE NO. OF DOCUMENT BEING CONTINUED

PAGE OF

M00681-87-R-0078

11

37

PAGES

NAME OF OFFICER OR CONTRACTOR

PART I - CONT'D
SECTION C - CONT'D

- (e) Contractor shall schedule his work so as to cause the least amount of interference with station operations. Work schedule shall be subject to the approval of the Contracting Officer.
- (f) Within sixty (60) days of commencement of operation of each co-generation system, contractor shall enter all changes and corrections on the original tracings. Changes and corrections, so entered, shall be indicated by a lettered circle and noted "As-built". Where no revisions or corrections on an individual drawing are necessary, the notation "As-built - No changes" shall be made. Where several manufacturers brands or types of classes of items have been used, the specific areas where each item was used shall be designated. Designations shall be keyed to the area and space designations on the contract drawings.

Information shall be furnished, typewritten, for the listed materials. Contractor shall maintain the "As-built" drawings in his file and shall continue to make all corrections necessary to reflect the "As-built" condition of the co-generation system. Copies of the "As-built" drawings shall be furnished, without cost, to the Contracting Officer and the Facilities Maintenance Officer within seventy-five (75) days of commencement of operation. In the event of termination of the contract, "As-built" drawings shall become the property of the Government and transferred to the Facilities Maintenance Officer, Marine Corps Base, Camp Pendleton.

- (g) Contractor shall be responsible for determining the requirements and obtaining, at his expense, any and all approvals, easements, or permits from governmental agencies or private parties having jurisdiction. Contractor shall be responsible for the preparation of all environmental documentation necessary to obtain the above approvals and permits. The contractor alone shall be responsible for any taxes, bonding, third party insurance, and other like charges associated with this contract.
- (h) The contractor must deliver two (2) sets of instruction manuals for each co-generation site to the Facilities Maintenance Officer, at no additional charge, within thirty (30) days of system start-up. Each set must contain all of the manuals needed to properly install, operate, and maintain the co-generation system.
- (i) Regular work hours are from 0700 - 1630, Monday through Friday. For work outside regular work hours, contractor shall submit written request to the Facilities Maintenance Officer, five (5) days prior to dates requested. At night, the contractor shall light the different areas of work site in a manner approved by the Facilities Maintenance Officer.
- (j) No piping or electrical wiring shall be installed under any floor slabs.
- (k) Utility systems shall be installed in accordance with existing codes (see "Co-generation system design). Installation of utility lines and pipes to the point of connection to existing lines, including all transformation from distribution to utilization voltage as may be required, or changes in pressures as may be required, will be the responsibility of the contractor. Contractor shall furnish all material, perform excavation, and make final connections.

D-11

PART I - CONT'D
SECTION C - CONT'D

- (1) The performance and quality of work delivered by the contractor, including services rendered and any documentation or written material compiled, shall be subject to inspection, review, and acceptance by the government (See Section E - Inspection and Acceptance).

CO-GENERATION SYSTEM OPERATION AND MAINTENANCE

- (a) Parallel operation of electrical generation facilities. The electrical generating facility shall be operated with all appropriate protective apparatus in service whenever any of the generators is connected to or is operated in parallel with the Camp Pendleton electrical system. The electrical generating facility and protective apparatus shall be operated and maintained in accordance with applicable standards and engineering practices specified by Rule 21 of SDG&E.
- (b) The below listed priorities shall be used in formulating the procedures for control or operation of the facilities. (Priorities are listed in decreasing order of importance, most important first).
- (1) Operate on-line at rated thermal and electrical capacity for the number of hours guaranteed per year.
- (2) Eliminate unscheduled shutdowns to avoid payment of added stand-by charge.
- (c) Log sheets: Contractor shall formulate a log sheet for each co-generating plant which details the operating and maintenance factors that apply to that plant. Contractor shall record scheduled and unscheduled periods of system maintenance, indicating causes of down time, length of downtime, and description of all repairs or modifications required. Log sheets shall be maintained on file for the duration of the contract. Contractor shall make any and all log sheets available to the Government within two (2) weeks after receipt of a written request specifying the log sheets to be provided. Current log sheets shall be made available to authorized representatives of the Government upon verbal request. All log sheets shall be turned over to the Government upon termination of the contract.
- (d) Planned outages shall be coordinated and scheduled with the Camp Pendleton Facilities Maintenance Officer. The term "Outage" means a downtime resulting in either definite or suspected inability to meet the loads. Contractor shall provide the Camp Pendleton Facilities Maintenance Officer with reasonable advance notice regarding outages. Reasonable advance notice is defined as follows:

EXPECTED DURATION OF OUTAGE/DOWNTIME

ADVANCED NOTICE

Less than one day
One to fifteen days
Over fifteen days

24 hours
1 week
1 month

PART I - CONT'DSECTION C - CONT'D

- (e) Contractor shall be responsible for operating the co-generation system so as to maintain its certification as a Qualified Facility (QF) by the Federal Energy Regulating Commission.
- (f) Contractor shall provide Operational Reports to the Facilities Maintenance Officer as shown on the "Schedule". The purpose of the reports are to periodically document the co-generation systems:
- (1) Operational hours
 - (2) Electrical energy (KW-hrs) delivered to Camp Pendleton Grid
 - (3) Thermal energy (MMBTU) used for generation of DHW
 - (4) Natural gas usage and heat content of gas
 - (5) Summary of co-generation system downtime showing periods of downtime, causes of downtime, and repairs or modifications required.
- (g) If the contractor performs unscheduled repair due to a catastrophic or unexpected failure of the system or any part thereof, the contractor shall submit in writing a full and detailed account of exactly what was done and why it was done. The written account shall be submitted to the Facilities Maintenance Officer and to the Co-generation Project Manager at Navy Civil Energy Laboratory (NCEL) as soon as possible at no charge to the Government. System modifications shall be undertaken only after written authorization for such modification has been received from the Contracting Officer.

THERMAL USAGE DATA FOR CO-GENERATION SITES

The data and discussion below describes the measured thermal loads at the co-generation sites (1-BEQ - Bldgs. 1396, 1397, and 1398 and 1-Mess Hall, Building 13100). In sizing the co-generation system which they offer, offerors should assume that the heat loads described in this proposal are the average heat loads that will be available, although it is anticipated that larger loads may actually be available during colder months.

A. BEQ COMPLEX - BUILDINGS 1396, 1397 and 1398:

Forty-five (45) days of hourly DHW (Domestic Hot Water) load data were collected during the period of 17 May 1986 to 14 July 1986. Plots of the data indicate two distinct DHW load profiles - one for weekdays and one for weekends. Daily DHW load data, maximum, minimum, average, and standard deviation values for weekdays and weekend days are contained in Table 2 - Attachment #3. A plot of average daily DHW consumption in MBTU'S per day showing daily load variation is shown in Figure 1 - Attachment #4. Hourly profiles for seven (7) days are shown on Figure 1.a - Attachment #5.

Changes in daily occupancy, which vary with troop field exercises, work schedules, leave, and weekend travel, accounts for variation in weekday and weekend total DHW consumption. The building manager reported that occupancy generally varies between 80% to 100% of total allocated space occupancy on weekdays and 40% to 60% on weekends. Total allocated space occupancy for May and June were 710 and 700 occupants respectively.

PART I - CONT'DSECTION C - CONT'DA. BEQ COMPLEX - CONT'D

DHW consumption at BEQ type facilities is often correlated to building occupancy. Using the average DHW consumption (in gallons) during the metered period, and assuming 90% occupancy, the average daily DHW consumption in mens dormitories (with laundry facilities) Published in the 1984d ASHRAE SYSTEMS HANDBOOK. ASHRAE shows an average daily DHW consumption of 13.1 GAL/OCC and maximum daily DHW consumption of 22.0 GAL/OCC. Other studies of DHW consumption in BEQ-type facilities have reported average daily DHW loads ranging from 16 to 33 GAL/OCC (1, 2, 3).

Low DHW flowrates (below 10 GPM) not sensed by our meters resulted in an under estimate of the actual facility DHW load. Due to the nature of the load, large usage of DHW at high flowrates in the mornings and evenings, vary little or no DHW usage during hours between 2300 and 0500, and low to moderate DHW usage during hours between 0900 and 1600, the errors associated with flowrates below 10 GPM are probably small.

B. NESS HALL, BUILDING 13100:

Twenty-six (26) days of hourly DHW load data were collected during the period of 19 June 1986 to 4 August 1986. Plots of the data indicate two distinct profiles - one for the weekdays and one for weekends. Daily DHW data, maximum, minimum, average and standard deviation values for weekdays and weekend days are contained in Table 3 - Attachment #6. A plot of daily DHW consumption showing the variation of the load is shown in Figure 2-Attachment #7. Hourly profiles for DHW consumption are shown on Figure 2.A - Attachment #8 for seven (7) days.

The Base Food Service Office reported the average daily meal consumption during the metered period was 776 meals per day. The average daily DHW load is 4346 gallons. Dividing the average DHW load by the average number of meals served yields a DHW consumption parameter of 5.6 GAL/MEAL. Other studies of DHW consumption at three (3) dining facilities reported DHW consumption parameters ranging from 4.6 to 5.5 GAL/MEAL.

Low flowrates not sensed by our meters (under 6 GPM) under estimate the actual facility DHW load. An audit of the messhall identified two (2) pieces of equipment (10 total) having a maximum hot water flowrate below the sensitivity of the meter. Building audits also show that equipment consuming hot water is, typically, operated at maximum flow. Because most of the DHW mess hall equipment used hot water at rates above 6 GPM, the under estimation of the actual DHW load is small.

PART I - CONT'D

SECTION D - PACKAGING AND MARKING

COMMERCIAL PACKAGING OF SUPPLIES AND EQUIPMENT (1987 MAR - Contracting Office)

The Contractor shall package all shipments under this contract in accordance with the Contractor's standard practice to prevent deterioration and damage. Each item shall be prepared for shipment in a manner which will ensure arrival at destination in a satisfactory condition. Preparation for delivery shall comply with applicable carrier rules and regulations.

MARKING OF SHIPMENTS (1977 DEC - Contracting Office)

The Contractor shall mark all shipments under this contract in accordance with the edition of MIL-STD-129, "Marking for Shipment and Storage", in effect as of the date of the solicitation.

SECTION E - INSPECTION AND ACCEPTANCE

INSPECTION AND ACCEPTANCE WILL BE MADE BY THE FACILITIES MAINTENANCE OFFICER, OR HIS DULY AUTHORIZED REPRESENTATIVE.

FINAL ACCEPTANCE WILL BE MADE BY THE FACILITIES MAINTENANCE OFFICER, OR HIS DULY AUTHORIZED REPRESENTATIVE, BUT ONLY AFTER THE BELOW LISTED REQUIREMENTS HAVE BEEN MET:

1. That the actual thermal and electrical capacities of the installed co-generation units are as stated in offer and have been successfully demonstrated for thirty (30) consecutive days of operation.
2. That all installation of the co-generation system; piping, electrical lines, controls, valves and switches, and meters are all installed according to the government approved designs.
3. All construction and installation are in accordance with applicable construction codes.
4. All required permits and approvals for construction and operation of the units have been obtained by the Contractor.
5. All electrical generation, hook-up, and metering equipment are in accordance with submitted and approved plans and with Rule 21 of SDG&E.
6. The co-generation systems are installed in such a way as to satisfactorily interface with the operation and maintenance of existing systems and to permit proper maintenance of the co-generation system.
7. Co-generation systems are appropriately protected from the weather.
8. That signals which indicate values of "measured variables" and "calculated variables" are in a form which can be used for electronic transmission.
9. That appropriate dry-contract switches which can be used to provide system status information have been installed.

PART I - CONT'DSECTION E - CONT'D

10. That auxiliary equipment (e.g., hot-water storage tanks and pumps) are sufficient for providing the thermal and electrical services stated in offer.
11. That systems controls provide for: (1) automatic and independent operation of the co-generation units and (2) necessary valves, switches and controls so that failure or shut-down of the co-generation units will not cause interruption of the supply of thermal or electrical energy to the site from other sources.

SECTION F - DELIVERIES OR PERFORMANCETIME OF DELIVERY AND INSTALLATION

The Government DESIRES that delivery and installation be made within ___ days after date of contract. If the offeror is unable to meet the desired delivery and installation time he may, without prejudice in the evaluation of his proposal, offer to make delivery and installation at another time provided that in no event shall the offerors delivery and installation schedule extend beyond ___ days after date of contract. Proposals offering delivery and installation after that time will be considered non-responsive to the Solicitation and will be rejected. In addition, any proposal offering an indefinite time of delivery and installation or offering delivery and installation contingent upon the availability or receipt of material will be rejected. Unless the offeror proposes a different delivery and installation schedule, the Government's DESIRED delivery and installation schedule stated above will apply.

OFFEROR'S PROPOSED DELIVERY AND INSTALLATION SCHEDULE
(To be completed by Offeror)

The articles to be furnished shall be delivered and installed within ___ days after date of Contract.

Attention is directed to the Contract Award provision of the solicitation that provides that a written award or acceptance of offer mailed, or otherwise furnished to the successful offeror, results in a binding contract. The Government will mail or otherwise furnish to the offeror an award or notice of award not later than the day award is dated. Therefore, the offeror should compute the time available for performance beginning with the actual date of award, rather than the date the written notice of award is received from the Contracting Officer through the ordinary mails. However, the Government will evaluate an offer that proposes delivery and installation based on the Contractor's date of receipt of the contract or notice of award by adding five days for delivery and installation of the award through the ordinary mails. If, as so computed, the offered delivery and installation date is later than the required delivery and installation date, the offer will be considered nonresponsive and rejected.

CONTINUATION SHEET

REFERENCE NO. OF DOCUMENT BEING CONTINUED

M00681-87-R-0078

PAGE

OF

37

37

PAGES

NAME OF OFFEROR OR CONTRACTOR

PART IV - CONT'D
SECTION M - CONT'D

The following elements will be used in the evaluation of each offeror's proposal for award, and are listed in decreasing order of importance.

- a. Co-generation systems annual savings and lowest simple payback (Attachment 2).
- b. The proven reliability of the equipment being offered.
- c. The proven capability of the contractor to adequately maintain and service the installed equipment.
- d. Experience level of the company in dealing with utilities on co-generation or other engineering projects.
- e. The past and present performance record of the offeror in carrying out contracts of this nature.
- f. The experience of key contractor personnel who will be involved in this contract.
- g. Prices, to consist of Section B.

CALCULATION OF PURPA EFFICIENCY

The following Table applies for calculation of PURPA EFFICIENCY as required by Section 201 of the Public Utility Regulatory Policies Act of 1978.

OPERATING AND EFFICIENCY STANDARDS

FOR CO-GENERATION FACILITIES

| TYPE OF FACILITY | OPERATING STANDARDS (BONAFIDE TEST) | EFFICIENCY STANDARDS | |
|------------------|---|------------------------------|---|
| | | INSTALLATIONS BEFORE 3-13-80 | INSTALLATIONS ON OR after 3-13-80 |
| TOPPING CYCLE | 5% of total energy output must be useful thermal energy | NO EFFICIENCY STANDARD | If thermal output is $> 15\%$, power output plus one-half of the thermal output must be at least 42.5% of annual oil and gas inputs. |
| | | | If thermal output is $< 15\%$, power output plus one-half of thermal output must be at least 45% of annual oil and gas inputs. |
| BOTTOMING CYCLE | NO OPERATING STANDARD | NO EFFICIENCY STANDARD | Useful power output must be at least 45% of annual oil and gas used for supplementary firing. |

M00681-87-R-0078

CALCULATION OF ANNUAL GOVERNMENT SAVINGS AND SIMPLE PAYBACK

1 SYSCOS = Cost of Installed Co-generation System = \$ _____

2 ONMRA = Annual Cost For O&M = \$ _____

3 CGEO = Co-generation Electrical Output = _____ KW

4 CGHO = Co-generation Heat Output = _____ BTU/Hr

5 CGFUKW = Heat Rate of Co-generation Unit = _____ BTU/KW-Hr

6 CGAVAIL = Guaranteed Co-generation Operational Hours/year = _____ Hrs.

7 OLDFUCOS = Old Fuel Cost per Year
 = $\frac{CGHO * CGAVAIL * \$5.09}{1,000,000 * 0.80}$ = \$ _____

8 NUFUCOS = New Fuel Cost per Year
 = $\frac{CGAVAIL * CGEO * (2.89 * 11,500 + (CGFUKW - 11,500) * 5.09)}{1,000,000}$
 = \$ _____

FUSAV = Annual Fuel Savings
 = OLDFUCOS - NUFUCOS = \$ _____

ELSAV = Annual Electrical Savings
 = CGAVAIL * CGEO * 0.088 = \$ _____

NETSAV = FUSAV + ELSAV - ONMRA = \$ _____

Payback = $\frac{SYSCOS}{NETSAV}$ = _____ Yrs

DISTRIBUTION LIST

AF 438 ABG/DEE (Wilson) McGuire AFB, NJ; 6550 CES/DEEE, Patrick AFB, FL; AFIT/DET (Hudson), Wright-Patterson AFB, OH; AFIT/DET, Wright-Patterson AFB, OH; Capt Holland, Saudia Arabia
AF HQ ESD/AVMS, Hanscom AFB, MA; ESD/DEE, Hanscom AFB, MA; LETT (Cargo), Washington, DC
AFB 42 CES/Ready Offr, Loring AFB, ME
AFESC TIC (library), Tyndall AFB, FL
ARMY 416th ENCOM, Akron Survey Tm, Akron, OH; CECOM R&D Tech Lib, Ft Monmouth, NJ; Ch of Engrs, DAEN-MPU, Washington, DC; Engr Cen, ATSE-DAC-LC, Ft Leonard Wood, MO; HHC, 7th ATC (Ross), Grafenwohr, GE; HQ Europe Cmd, AEAEN-FE-U, Heidelberg, GE; Kwajalein Atoll.
BMDS-C, Marshall Is; POJED-O, Okinawa, Japan; R&D Cmd, STRNC-US (J Siegel), Natick, MA
ARMY BELVOIR R&D CEN ATSE-DAC-LB, Ft Leonard Wood, MO; STRBE-FS, Ft Belvoir, VA
ARMY CERL Library, Champaign, IL
ARMY CRREL CRREL-EC (Flanders), Hanover, NY
ARMY DEPOT Letterkenny, SDSLE-EF, Chambersburg, PA
ARMY EHA HSHB-EW, Aberdeen Proving Grnd, MD
ARMY ENGR DIST Library, Portland, OR
ARMY EWES Library, Vicksburg MS
ARMY LOGC ALC/ATCI-MS (Morrissett), Fort Lee, VA
ARMY TRADOC ATEN-FE, Ft Monroe, VA
ADMINSUPU PWO, Bahrain
BUREAU OF RECLAMATION D-1512 (GS DePuy), Denver, CO
CBC Code 15, Port Hueneme, CA; PWO (Code 400), Gulfport, MS; PWO (Code 80), Port Hueneme, CA; PWO, Davisville, RI; Tech Library, Gulfport, MS
CG FMF Lant, SCE, Norfolk, VA
CINCLANTFLT CE Supp Plans Offr, Norfolk, VA
CINCUSNAVEUR London, UK
CNA Tech Library, Alexandria, VA
COGARD R&DC Library, Groton, CT
COMDT COGARD Library, Washington, DC
COMFAIR Med, SCE, Naples, Italy
COMFLEACT PWO, Kadena, Japan; PWO, Sasebo, Japan
COMNAVACT PWO, London, UK
COMNAVIRSYSCOM AIR-714, Washington, DC; Code 41712A, Washington, DC; Code 422, Washington, DC
COMNAVMARIANAS Code N4, Guam
COMNAVSUPFORANTARCTICA DET, PWO, Christchurch, NZ
COMOCEANSYS Lant, Code N9, Norfolk, VA
COMUSNAV CENT, Code N42, Pearl Harbor, HI
DFSC DFSE-F, Alexandria, VA
DIRSSP Tech Lib, Washington, DC
DOE INEL Tech Lib Reports Sta, Idaho Falls, ID; Wind/Ocean Tech Div, Tobacco, MD
DTIC Alexandria, VA
DTRCEN Code 1250, Annapolis, MD; Code 42, Bethesda MD; Code 522, Annapolis, MD
EFA-SW Code 101.1, San Diego, CA
FCTC LANT, PWO, Virginia Bch, VA
GSA Ch Engrg Br, PQB, Washington, DC; Code PCDP, Washington, DC
LIBRARY OF CONGRESS Sci & Tech Div, Washington, DC
MAG 16, CO, MCAS Tustin, CA
MARCORBASE Code 405, Camp Lejeune, NC; PAC, PWO, Camp Butler, JA
MARITIME ADMIN MAR-770 (Corkrey), Washington, DC; MMA, Library, Kings Point, NY
MCLB Code 555, Albany, GA
MCAS Code LCU, Cherry Point, NC; El Toro, Code IJD, Santa Ana, CA; PWO, Kaneohe Bay, HI; PWO, Yuma, AZ
MCLB Maint Offr, Barstow, CA; PWO, Barstow, CA
MCRD PWO, San Diego, CA
MCRDAC AROICC, Quantico, VA; Mech Engrg Mgr, PWO, Quantico, VA; PWD, Quantico, VA
NAF Dir, Engrg Div, PWD, Atsugi, Japan; PWO, Atsugi, Japan
NAS Chase Fld, Code 18300, Beeville, TX; Chase Fld, PWO, Beeville, TX; Code 1833, Corpus Christi, TX; Code 187, Jacksonville, FL; Code 18700, Brunswick, ME; Code 6234 (C Arnold), Point Mugu, CA; Code 70, Marietta, GA; Fac Mgmt Offc, Alameda, CA; Memphis, PWO, Millington, TN; Miramar, PWO Code 187, San Diego, CA; Miramar, PWO, San Diego, CA; Oceana, PWO, Virginia Bch, VA; PW Engrg (Branson), Patuxent River, MD; PWO (Code 182) Bermuda; PWO, Adak, AK; PWO, Bermuda; PWO, Cecil Field, FL; PWO, Dallas, TX; PWO, Glenview, IL; PWO, Keflavik, Iceland; PWO, Key West, FL; PWO, Kingsville TX; PWO, Moffett Field, CA; PWO, New Orleans, LA; PWO, Sigonella, Italy; PWO, South Weymouth, MA; PWO, Willow Grove, PA; SCE, Norfolk, VA; Whiting Fld, PWO, Milton, FL

NAVAIRDEVCEN Code 832, Warminster, PA
NAVAIRENGCEN PWO, Lakehurst, NJ
NAVAIRPROPCEN CO, Trenton, NJ
NAVAIRTESTCEN PWO, Patuxent River, MD
NAVAMPHIB BASE Naval Amphib Base - LC, Norfolk, VA
NAVAUDSVCHQ Director, Falls Church VA
NAVAVIONICCEN PWO, Indianapolis, IN
NAVAVNDEPOT Code 61000, Cherry Point, NC; SCE, Norfolk, VA
NAVCAMS MED, SCE, Naples, Italy; PWO, Norfolk, VA; SCE, Wahiawa, HI; WestPac, SCE, Guam,
Mariana Islands
NAVCOASTSYSCEN CO, Panama City, FL; PWO (Code 740), Panama City, FL; Tech Library, Panama City,
FL
NAVCOMMSTA Code 401, Nea Makri, Greece; PWO, Exmouth, Australia; PWO, Thurso, UK
NAVELEXCEN DET, OIC, Winter Harbor, ME
NAVEODTECHCEN Tech Library, Indian Head, MD
NAVFAC Centerville Bch, PWO, Ferndale, CA; N62, Argentia, NF; PWO (Code 50), Brawdy Wales, UK;
PWO, Oak Harbor, WA
NAVFACENGCOM Code 03, Alexandria, VA; Code 04A, Alexandria, VA; Code 051A, Alexandria, VA; Code
06, Alexandria, VA; Code 083, Alexandria, VA; Code 09M124 (Lib), Alexandria, VA; Code 163,
Alexandria, VA; Code 1653 (Hanneman), Alexandria, VA; Code 18, Alexandria, VA
NAVFACENGCOM - CHES DIV, Code 112.1, Washington, DC; FPO-IPL, Washington, DC
NAVFACENGCOM - LANT DIV, Br Ofc, Dir, Naples, Italy
NAVFACENGCOM - NORTH DIV, Code 04AL, Philadelphia, PA; Code 11, Philadelphia, PA
NAVFACENGCOM - PAC DIV, Library, Pearl Harbor, HI
NAVFACENGCOM - SOUTH DIV, Library, Charleston, SC
NAVFACENGCOM - WEST DIV, 09P/20, San Bruno, CA; Code 04A2.2 (Lib), San Bruno, CA; Code 09B, San
Bruno, CA
NAVFACENGCOM CONTRACTS OICC, Guam; ROICC, Keflavik, Iceland
NAVHOSP PWO, Okinawa, Japan; SCE, Guam, Mariana Islands; SCE, Newport, RI
NAVMARCORESCEN LTJG Davis, Raleigh, NC
NAVMEDCOM SWREG, SCE, San Diego, CA
NAVOCEANCOMCEN Code EES, Guam, Mariana Islands
NAVORDSTA Code 0922B1, Indian Head, MD
NAVPETOFF Code 40, Alexandria, VA
NAVPETRES Director, Washington DC
NAVPGSCOL Code 1424, Library, Monterey, CA; PWO, Monterey, CA
NAVPHIBASE PWO, Norfolk, VA
NAVSCSCOL PWO, Athens, GA
NAVSEASYSCOM Code PMS296L22 (J Rekas), Washington, DC
NAVSECGRU Code G43, Washington, DC
NAVSECGRUACT PWO (Code 40), Edzell, Scotland; PWO, Adak, AK
NAVSECSTA Code 60, Washington, DC
NAVSHIPYD Code 308.3, Pearl Harbor, HI; Library, Portsmouth, NH; Mare Island, Code 401, Vallejo, CA;
Mare Island, PWO, Vallejo, CA; Norfolk, Code 440, Portsmouth, VA; PWO (Code 400), Long Beach, CA;
PWO, Bremerton, WA; PWO, Charleston, SC
NAVSTA CO, Brooklyn, NY; Dir, Engr Div, PWD, Guantanamo Bay, Cuba; Engrg Dir, PWD, Rota, Spain;
PWO, Mayport, FL; Util Engrg Offr, Rota, Spain; WC 93, Guantanamo Bay, Cuba
NAVSUPPACT CO, Naples, Italy; PWO, Naples, Italy
NAVSUPSYSCOM Code 0622, Washington, DC
NAVSWC DET, White Oak Lab, PWO, Silver Spring, MD; PWO, Dahlgren, VA
NAVUSEAWARENGSTA Code 073, Keyport, WA
NAVWPNCEN PWO (Code 266), China Lake, CA
NAVWPNSTA Code 092, Concord, CA; Dir, Maint Control, PWD, Concord, CA; Earle, PWO (Code 09B),
Colts Neck, NJ; PWO, Charleston, SC; PWO, Seal Beach, CA; PWO, Yorktown, VA
NAVWPNSUPPCEN PWO, Crane, IN
NETC PWO, Newport, RI
NETPMSA Tech Library, Pensacola, FL
NMCB 3, Ops Offr; 40, CO; 5, Ops Dept; 62, Engrg Offr
NOAA Library, Rockville, MD
NORDA Code 1121SP, Bay St. Louis, MS; Code 352, Bay St. Louis, MS
NRL Code 2511, Washington, DC
NSC Cheatham Annex, PWO, Williamsburg, VA; SCE, Norfolk, VA

NUSC DET Code 44 (RS Munn), New London, CT
PACMISRANFAC HI Area, PWO, Kekaha, HI
PWC ACE (Code 110), Great Lakes, IL; ACE Office, Norfolk, VA; Code 10, Oakland, CA; Code 1011, Pearl Harbor, HI; Code 30, Norfolk, VA; Code 400, Great Lakes, IL; Code 400, Pearl Harbor, HI; Code 421, San Diego, CA; Code 500, Great Lakes, IL; Code 590, San Diego, CA; Code 600, Great Lakes, IL; Code 610, San Diego, CA; Code 612, Pearl Harbor, HI; Code 615, Guam, Mariana Islands; Library (Code 134), Pearl Harbor, HI; Library, Guam, Mariana Islands; Library, Norfolk, VA; Library, Pensacola, FL; Library, Yokosuka, Japan; PWC, C-422, Pearl Harbor, HI; Tech Library, Subic Bay, RP
SPCC PWO (Code 08X), Mechanicsburg, PA
SUPSHIP Tech Library, Newport News, VA
USAFE DE-HFO, Ramstein AB, GE
USDA For Svc Reg 3, Engr Tech Staff, Albuquerque, NM; For Svc, Tech Engrs, Washington, DC
USNA Ch, Mech Engrg Dept, Annapolis, MD
USS USS FULTON, Code W-3
CONNECTICUT Policy & Mgmt, Energy Div, Hartford, CT
LAWRENCE LIVERMORE NATL LAB Plant Engrg Lib (L-654), Livermore, CA
LOUISIANA Nat Res Dept, R&D, Baton Rouge, LA
MAINE Energy Rscs Ofc, Augusta, ME
MAINE MARITIME ACADEMY Lib, Castine, ME
MISSOURI Nat Res Dept, Energy Div, Jefferson City, MO
MIT Engrg Lib, Cambridge, MA
MONTANA Energy Ofc (Anderson), Helena, MT
NATL ACADEMY OF SCIENCES NRC, Naval Studies Bd, Washington, DC
NEW HAMPSHIRE Gov Energy Ofc, Asst Dir, Concord, NH
NEW YORK Energy Office, Lib, Albany, NY
NEW YORK STATE MARITIME COLLEGE Longobardi, Bronx, NY
NY CITY COMMUNITY COLLEGE Library, Brooklyn, NY
PURDUE UNIVERSITY Engrg Lib, W. Lafayette, IN
VENTURA COUNTY Deputy PW Dir, Ventura, CA
WORCESTER POLYTECH INST Mech Engrg Dept (Sullivan), Worcester, MA
BATTELLE New Eng Marine Rsch Lab, Lib, Duxbury, MA
CHEMED CORP Dearborn Chem Div Lib, Lake Zurich, IL
RAYMOND INTL, INC Soil Tech Dept (E Colle), Pennsauken, NJ
TANDEMLOC, INC J DiMartino, Jr, Ronkonkoma, NY
TEXTRON, INC Rsch Cen Lib, Buffalo, NY
UNITED TECHNOLOGIES Hamilton Std Div, Lib, Windsor Locks, CT
STEVENS, TW Dayton, OH

INSTRUCTIONS

The Naval Civil Engineering Laboratory has revised its primary distribution lists. The bottom of the label on the reverse side has several numbers listed. These numbers correspond to numbers assigned to the list of Subject Categories. Numbers on the label corresponding to those on the list indicate the subject category and type of documents you are presently receiving. If you are satisfied, throw this card away (or file it for later reference).

If you want to change what you are presently receiving:

- Delete – mark off number on bottom of label.
- Add – circle number on list.
- Remove my name from all your lists – check box on list.
- Change my address – line out incorrect line and write in correction (**DO NOT REMOVE LABEL**).
- Number of copies should be entered after the title of the subject categories you select.

Fold on line below and drop in the mail.

Note: Numbers on label but not listed on questionnaire are for NCEL use only, please ignore them.

Fold on line and staple.

DEPARTMENT OF THE NAVY

Naval Civil Engineering Laboratory
Port Hueneme, CA 93043-5003

Official Business
Penalty for Private Use, \$300

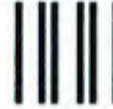

BUSINESS REPLY CARD

FIRST CLASS PERMIT NO. 12503 WASH D.C.

POSTAGE WILL BE PAID BY ADDRESSEE

NO POSTAGE
NECESSARY
IF MAILED
IN THE
UNITED STATES

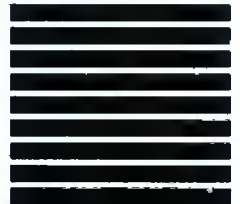

Commanding Officer
Code L34
Naval Civil Engineering Laboratory
Port Hueneme, California 93043-5003

DISTRIBUTION QUESTIONNAIRE

The Naval Civil Engineering Laboratory is revising its Primary distribution lists.

SUBJECT CATEGORIES

- 1 SHORE FACILITIES
- 2 Construction methods and materials (including corrosion control, coatings)
- 3 Waterfront structures (maintenance/deterioration control)
- 4 Utilities (including power conditioning)
- 5 Explosives safety
- 6 Aviation Engineering Test Facilities
- 7 Fire prevention and control
- 8 Antenna technology
- 9 Structural analysis and design (including numerical and computer techniques)
- 10 Protective construction (including hardened shelters, shock and vibration studies)
- 11 Soil/rock mechanics
- 14 Airfields and pavements

- 15 ADVANCED BASE AND AMPHIBIOUS FACILITIES
- 16 Base facilities (including shelters, power generation, water supplies)
- 17 Expedient roads/airfields/bridges
- 18 Amphibious operations (including breakwaters, wave forces)
- 19 Over-the-Beach operations (including containerization, material transfer, lighterage and cranes)
- 20 POL storage, transfer and distribution

TYPES OF DOCUMENTS

- 85 Techdata Sheets
- 86 Technical Reports and Technical Notes
- 83 Table of Contents & Index to TDS

28 ENERGY/POWER GENERATION

- 29 Thermal conservation (thermal engineering of buildings, HVAC systems, energy loss measurement, power generation)
- 30 Controls and electrical conservation (electrical systems, energy monitoring and control systems)
- 31 Fuel flexibility (liquid fuels, coal utilization, energy from solid waste)
- 32 Alternate energy source (geothermal power, photovoltaic power systems, solar systems, wind systems, energy storage systems)
- 33 Site data and systems integration (energy resource data, energy consumption data, integrating energy systems)
- 34 ENVIRONMENTAL PROTECTION
- 35 Hazardous waste minimization
- 36 Restoration of installations (hazardous waste)
- 37 Waste water management and sanitary engineering
- 38 Oil pollution removal and recovery
- 39 Air pollution

44 OCEAN ENGINEERING

- 45 Seafloor soils and foundations
- 46 Seafloor construction systems and operations (including diver and manipulator tools)
- 47 Undersea structures and materials
- 48 Anchors and moorings
- 49 Undersea power systems, electromechanical cables, and connectors
- 50 Pressure vessel facilities
- 51 Physical environment (including site surveying)
- 52 Ocean-based concrete structures
- 54 Undersea cable dynamics

- 82 NCEL Guides & Abstracts
- 91 Physical Security

None-
remove my name

NCEL DOCUMENT EVALUATION

You are number one with us; how do we rate with you?

We at NCEL want to provide you our customer the best possible reports but we need your help. Therefore, I ask you to please take the time from your busy schedule to fill out this questionnaire. Your response will assist us in providing the best reports possible for our users. I wish to thank you in advance for your assistance. I assure you that the information you provide will help us to be more responsive to your future needs.



R. N. STORER, Ph.D, P.E.
Technical Director

DOCUMENT NO. _____ TITLE OF DOCUMENT: _____

Date: _____ Respondent Organization : _____

Name: _____ Activity Code: _____
Phone: _____ Grade/Rank: _____

Category (please check):

Sponsor _____ User _____ Proponent _____ Other (Specify) _____

Please answer on your behalf only; not on your organization's. Please check (use an X) only the block that most closely describes your attitude or feeling toward that statement:

SA Strongly Agree A Agree O Neutral D Disagree SD Strongly Disagree

| | SA A N D SD | | SA A N D SD |
|--|---------------------|---|---------------------|
| 1. The technical quality of the report is comparable to most of my other sources of technical information. | () () () () () | 6. The conclusions and recommendations are clear and directly supported by the contents of the report. | () () () () () |
| 2. The report will make significant improvements in the cost and or performance of my operation. | () () () () () | 7. The graphics, tables, and photographs are well done. | () () () () () |
| 3. The report acknowledges related work accomplished by others. | () () () () () | Do you wish to continue getting NCEL reports? <input type="checkbox"/> YES <input type="checkbox"/> NO | |
| 4. The report is well formatted. | () () () () () | Please add any comments (e.g., in what ways can we improve the quality of our reports?) on the back of this form. | |
| 5. The report is clearly written. | () () () () () | | |

Comments:

Please fold on line and staple

DEPARTMENT OF THE NAVY

Naval Civil Engineering Laboratory
Port Hueneme, CA 93043-5003

Official Business
Penalty for Private Use \$300



Code L03B
NAVAL CIVIL ENGINEERING LABORATORY
PORT HUENEME, CA 93043-5003

DEPARTMENT OF THE NAVY

Naval Civil Engineering Laboratory
Port Hueneme, CA 93043-5003

Official Business
Penalty for Private Use \$300

